

SMB Booster set

SMB../SVE, SMB../VME, SMB../HME
Installation, Operation and Maintenance Manual

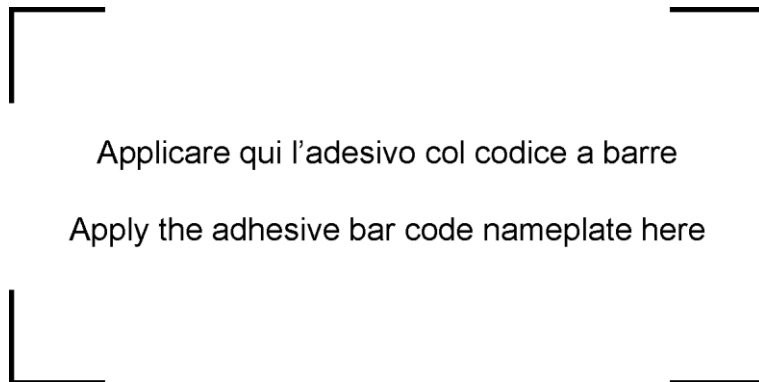

a xylem brand

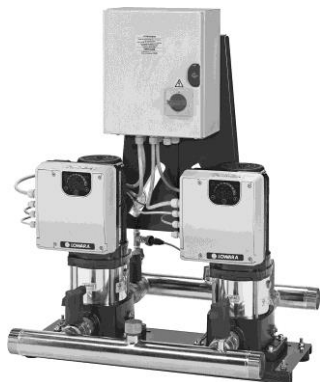

Applicare qui l'adesivo col codice a barre

Apply the adhesive bar code nameplate here



Table of Contents

1	Introduction and Safety	5
1.1	Introduction.....	5
1.2	Safety	5
1.2.1	Danger levels and safety symbols	5
1.2.2	User safety	6
1.2.3	General safety rules	7
1.2.4	Protection of the environment	8
1.2.5	Sites exposed to ionizing radiations	8
1.3	Spare parts	8
1.4	Product warranty	8
2	Transportation and Storage	9
2.1	Handling the booster set	9
2.2	Storage.....	10
3	Technical Description	11
3.1	Designation	11
3.2	Data plates	11
3.2.1	Booster set	11
3.2.2	Distribution panel.....	12
3.3	Design and layout.....	13
3.4	Intended use.....	14
3.4.1	Application alternatives	14
3.5	Improper use	14
4	Installation	15
4.1	Mechanical installation	15
4.1.1	Installation area	15
4.1.2	Guidelines for mechanical installation.....	16
4.2	Hydraulic installation	16
4.2.1	Guidelines for hydraulic installation.....	17
4.3	Electrical Installation	18
4.3.1	Electrical requirements.....	18
4.3.2	Electrical connection checklist	18
4.3.3	Electrical control panel check-list.....	18
4.3.4	Wire types and ratings.....	19
4.3.5	Protection against dry running	20
5	Use and operation	21
5.1	Wait times.....	21
5.2	Starting and stopping	21
5.2.1	Adjusting the frequency converter.....	22
5.2.2	Pre-charging the diaphragm pressure tank.....	22

5.2.3	Starting the booster set	22
6	Maintenance	24
6.1	Maintenance of the control panel and frequency converters	24
6.2	Maintenance of the diaphragm pressure tank.....	24
7	Troubleshooting	25
7.1	The booster set is off.....	25
7.2	Motor does not start	25
7.3	Frequent start-ups and stops	25
7.4	The speed of the pump unit increases and decreases without stopping and without consumption of water (utility closed).....	25
7.5	The motor runs but no water is delivered.....	26
7.6	Loss of water from the pump unit.....	26
7.7	Too noisy	26
7.8	The booster set does not generate the required pressure.....	26
7.9	Tripping of the main protection system (fuses)	26
7.10	Tripping of the differential protection.....	27
7.11	The pump unit runs at maximum speed without stopping	27
7.12	Only one pump unit is running	27
7.13	There is demand for water but the pump unit does not start	27
8	Technical Data	28
8.1	Dimensions and weights	29
9	Declarations	29
9.1	EC Declaration of Conformity (Original).....	29
9.2	EU Declaration of Conformity (No EMCD23).....	29

1 Introduction and Safety



1.1 Introduction

Purpose of this manual

The purpose of this manual is to provide necessary information for:

- Installation
- Operation
- Maintenance



CAUTION:

Before installing and using the product, make sure that you read and fully understand this manual in all its parts. Improper use of the product can cause personal injuries and damage to property, as well as making the warranty null and void.

NOTICE:

This manual is an integral part of the product. It must always be made available to the user, stored in the proximity of the product, and well kept.



1.2 Safety

1.2.1 Danger levels and safety symbols

Before using the product, and in order to avoid the following risks, make sure that you carefully read, understand and comply with the following danger warnings:







- Injuries and health hazards
- Damage to the product
- Product malfunction.

Hazard levels



Hazard level	Indication
 DANGER:	It identifies a dangerous situation which, if not avoided, causes serious injury, or even death.
 WARNING:	It identifies a dangerous situation which, if not avoided, may cause serious injury, or even death.
 CAUTION:	It identifies a dangerous situation which, if not avoided, may cause small or medium level injuries.
NOTICE:	It identifies a situation which, if not avoided, may cause damage to property but not to people.

Special symbols

Some hazard categories have specific symbols, as shown in the following table:

Symbol	Description
	Electrical hazard
	Magnetic hazard
	Hot surface hazard
	Ionizing radiation hazard
	Potentially explosive atmosphere hazard (ATEX EU Directive)
	Cut and abrasion hazard
	Crushing hazard (limbs)

Other symbols

Symbol	Description
	User Specific information for the users of the product.
	Installer / Maintenance technician Specific information for personnel responsible for the installation of the product within the system (hydraulic and/or electric system), and for maintenance operations.

1.2.2 User safety

Strictly comply with current health and safety regulations.



WARNING:

This product must be used only by qualified users.

For the purposes of this manual, in addition to the provisions of any local regulations, qualified personnel means any individuals who, due to their experience or training, are capable of recognising any existing hazards and to avoiding dangers during the installation, the use and the maintenance of the product.

Inexperienced users



WARNING:

FOR THE EUROPEAN UNION

- This appliance can be used by children aged from 8 years and above and persons with reduced physical, sensory or mental capabilities or lack of experience and knowledge if they have been given supervision or instruction concerning use of the appliance in a safe way and understand the hazards involved.
- Children shall not play with the appliance.
- Cleaning and user maintenance shall not be made by children without supervision.

FOR OTHER COUNTRIES

- This appliance is not intended for use by persons (including children) with reduced physical, sensory or mental capabilities, or lack of experience and knowledge, unless they have been given supervision or instruction concerning use of the appliance by a person responsible for their safety.
- Children should be supervised to ensure that they do not play with the appliance.

1.2.3 General safety rules



WARNING:

- Always keep the work area clean.
- Pay attention to the risks presented by gas and vapors in the work area.
- Always bear in mind the risk of drowning, electrical accidents, and burn injuries.



DANGER: Electrical hazard

- Avoid all electric dangers; pay attention to the risk of electric shock or electric arcs
- Unintended rotation of motors creates voltage and can charge the unit, resulting in death, serious injury, or equipment damage. Ensure that motors are blocked to prevent unintended rotation.

Magnetic fields

The removal or installation of the rotor in the motor casing generates a strong magnetic field.



DANGER: Magnetic hazard

The magnetic field may be dangerous for anyone wearing pacemakers, or any other medical devices sensitive to magnetic fields.

NOTE

The magnetic field may attract metal debris on the rotor surface, causing damage to the same.

Electrical connections



DANGER: Electrical hazard

- The connection to the electric power supply must be completed by an electrician possessing the technical-professional requirements outlined in the current regulations

Precautions before work



WARNING:

- Install a suitable barrier around the working area, for example a guard rail
- Make sure that all safety guards are in place and secure.
- Make sure that you have a clear path of retreat.
- Make sure that the product cannot roll or fall over and injure people or damage property.
- Make sure that the lifting equipment is in good condition.
- Use a lifting harness, a safety line, and a breathing device as required.

- Allow all booster set components to cool before handling them
 - Make sure that the product has been thoroughly cleaned
 - Disconnect and lock out power before you service the pump unit.
 - Check the explosion risk before you weld or use electric hand tools.
-

Precautions during work



WARNING:

- Never work alone.
 - Always wear personal protective equipment
 - Always use suitable working tools
 - Always lift the product by its lifting device.
 - Stay clear of suspended loads.
 - Beware of the risk of a sudden start if the product is used with an automatic level control.
 - Beware of the starting jerk, which can be powerful.
 - Rinse the components in water after you disassemble the pump unit.
 - Do not exceed the maximum working pressure of the pump unit.
 - Do not open any vent or drain valve or remove any plugs while the booster set is pressurized.
 - Make sure that the pump unit is isolated from the system and that all pressure is released before disassembling the pump, removing plugs, or disconnecting the piping.
 - Never operate the pump unit without a properly installed coupling guard.
-

In case of contact with chemical substances or dangerous liquids

Follow these procedures for chemicals or hazardous fluids that have come into contact with your eyes or your skin:

Condition	Action
Chemicals or hazardous fluids in eyes	<ol style="list-style-type: none">1. Hold your eyelids apart forcibly with your fingers.2. Rinse the eyes with eyewash or running water for at least 15 min.3. Seek medical attention.
Chemicals or hazardous fluids on skin	<ol style="list-style-type: none">1. Remove contaminated clothing.2. Wash the skin with soap and water for at least 1 min.3. Seek medical attention, if necessary.

1.2.4 Protection of the environment

Disposal of packaging and product

Comply with the current regulations on sorted waste disposal.

1.2.5 Sites exposed to ionizing radiations



WARNING: Ionizing radiation hazard

If the product has been exposed to ionizing radiations, implement the necessary safety measures for the protection of people. If the product needs to be despatched, inform the carrier and the recipient accordingly, so that appropriate safety measures can be put in place.

1.3 Spare parts

When contacting Xylem or the Authorised Distributor to request technical information or spare parts, always indicate the product type and code.

1.4 Product warranty

For information on the warranty refer to the documentation of the sale contract.

2 Transportation and Storage



Packaging inspection

1. Check that quantity, descriptions and product codes match the order.
 2. Check the packaging for any damage or missing components.
 3. In case of immediately detectable damage or missing parts:
 - Accept the goods with reserve, indicating any findings on the transport document, or
 - Reject the goods, indicating the reason on the transport document.
- In both cases, promptly contact Xylem or the Authorised Distributor from whom the product was purchased.

Unpacking and inspection of the product

1. Remove the packaging material from the product.
2. Release the product by removing the screws and/or cutting the straps, if fitted.



CAUTION: Cut and abrasion hazard

Always wear personal protective equipment.

3. Check the product for integrity and to make sure that there are no missing components.
4. In case of damage or missing components, promptly contact Xylem or the Authorised Distributor.

2.1 Handling the booster set

The booster set must be harnessed and lifted as shown in Figure 1.



WARNING: Crushing hazard (limbs)

- The product and its components may be heavy: risk of crushing
 - Always wear personal protective equipment
 - Manual handling of the product and its components must be in compliance with the current regulations on "manual load handling", to avoid unfavourable ergonomic conditions causing risks of back-spine injury.
 - Use cranes, ropes, lifting straps, hooks and clasps that comply with current regulations and that are suitable for the specific use
 - Make sure that the harnessing does not damage the booster set
 - During the lifting operations, always avoid sudden movements that could compromise the stability of the load
 - During handling, make sure to avoid injury to people and animals, and/or damage to property.
-

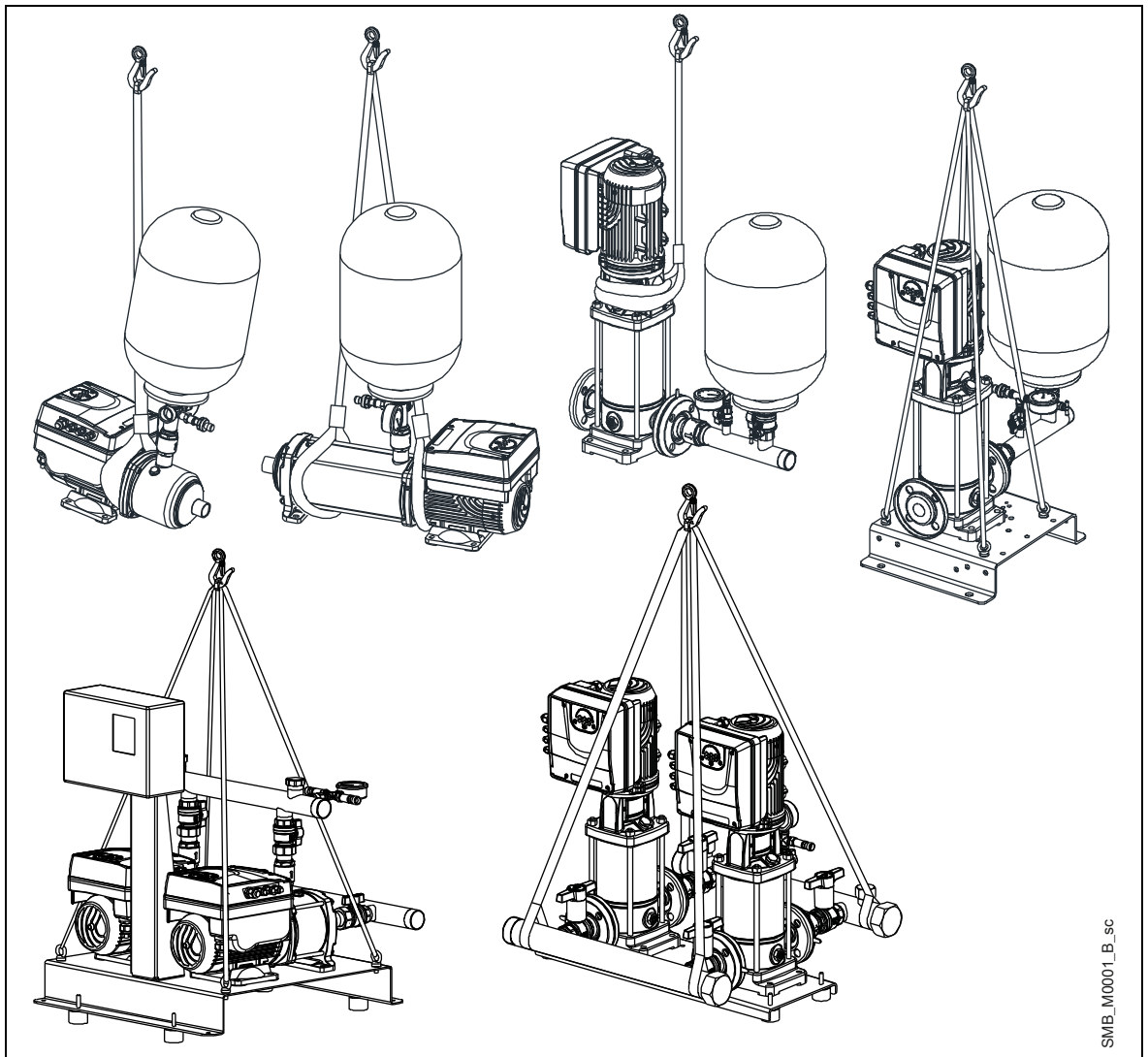

Figure 1: Lifting

2.2 Storage

The product must be stored:

- In a covered and dry place
- Away from heat sources
- Protected from dirt
- Protected from vibrations
- At an ambient temperature between -25°C and $+55^{\circ}\text{C}$ (-13°F and 131°F), and relative humidity between 5% and 95%.



NOTICE:

- Do not place heavy loads on top of the product
 - Protect the product from collisions.
-

3 Technical Description



3.1 Designation

Booster set consisting of one (SMB10) or more identical variable speed vertical or horizontal multistage non-self priming pump units (SMB20, SMB30) connected in parallel.

The pump units are mounted on a shared base with suction and delivery manifolds, on-off valves, non-return valves, pressure gauge, pressure transmitters and a single-phase or three-phase control panel. A booster set with one pump unit (SMB10) does not come with a control panel and it may not have a base.

There are 1" couplings on the delivery manifold for installing diaphragm pressure tanks with an on-off valve. The manifold, like the tanks, requires appropriate support.

Additional diaphragm pressure tanks can be installed and connected to the manifold.

3.2 Data plates

The data plate is a label showing:

- The main product details
- Identification code

Approval and certifications

For the approvals see the booster set data plate:

- only

3.2.1 Booster set

Data plate of the booster set

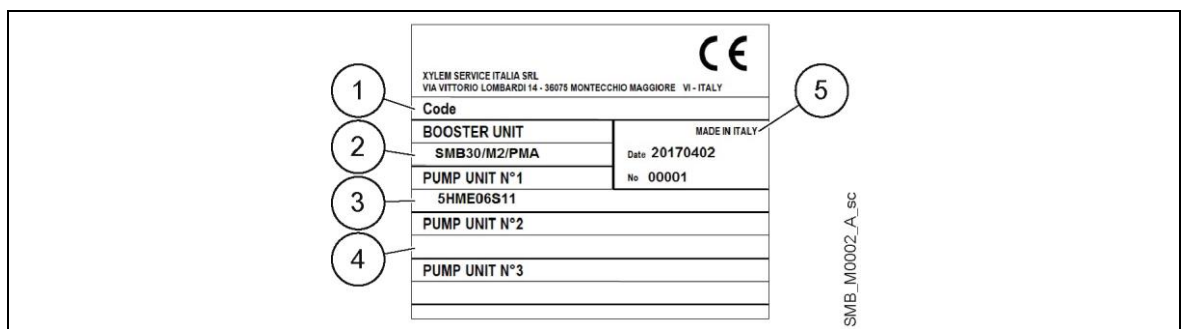

Figure 2: Data plate of the booster set

1. Code of the booster set
2. Booster set definition code
3. Electric service pump
4. Jockey pump
5. Serial number (date+progressive number)

Booster set definition code

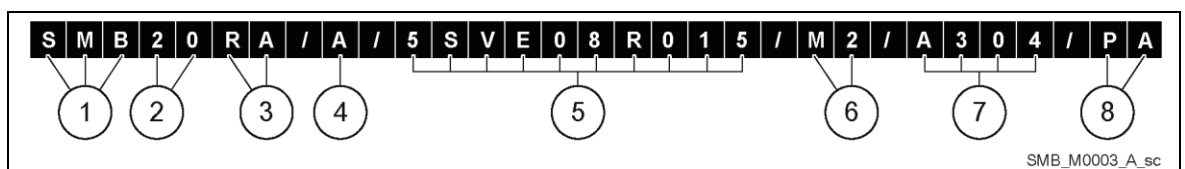

Figure 3: Booster set definition code

- | | |
|---------------------------------------|--------------------------------------------------------------------------------------------------------------------------------------------------------------------------------------------------------------------------------------------------------|
| 1. Series | SMB |
| 2. Number of pump units | [10] = 1 pump unit
[20] = 2 pump units
[30] = 3 pump units |
| 3. Non-return valve | [] = Delivery side
[RA] = Suction side |
| 4. Certificate of drinking water unit | A = WRAS, ACS, M.D.174
B = ACS, M.D.174
Z = not certified by a third party |
| 5. e-SM pump unit | SVE
VME
HME |
| 6. Control panel power supply | [M2] = Single-phase, 1 x 230 V
[T3] = Three-phase, 3 x 230 V
[T4] = Three-phase, 3 x 400 V |
| 7. Version of material | [] = Standard component
[A304] = Special AISI 304 version
[B304] = Special AISI 304 version
[C304] = Special AISI 304 version
[A316] = Special AISI 316 version
[B316] = Special AISI 316 version
[C316] = Special AISI 316 version |
| 8. Option | [PA] = Minimum pressure pressure switch on the suction manifold, for protection against dry running.
[WM] = Wall-mounted control panel; cables L= 5 m |

NOTE: Refer to the B/W catalogue for further details

3.2.2 Distribution panel

Data plate of the control panel

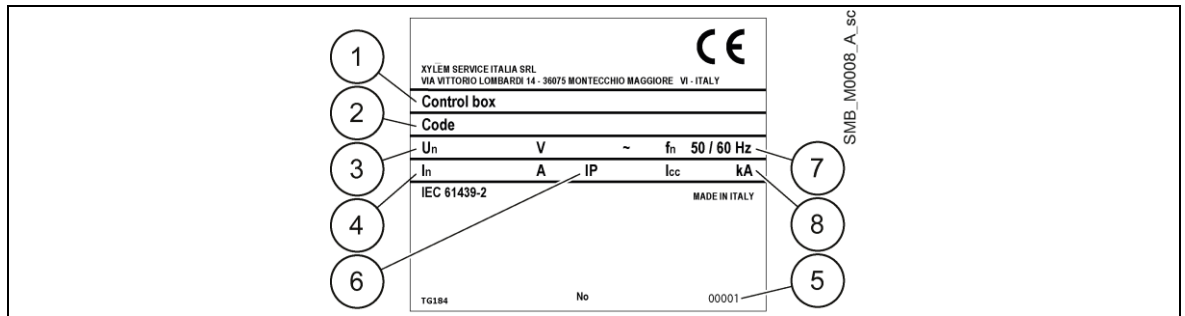

Figure 4: Data plate of the control panel

1. Control panel definition code
2. Code of the control panel
3. Rated voltage
4. Rated current
5. Serial number (date+progressive number)
6. Protection grade
7. Rated frequency
8. Short circuit current

3.3 Design and layout

Booster set in standard configuration

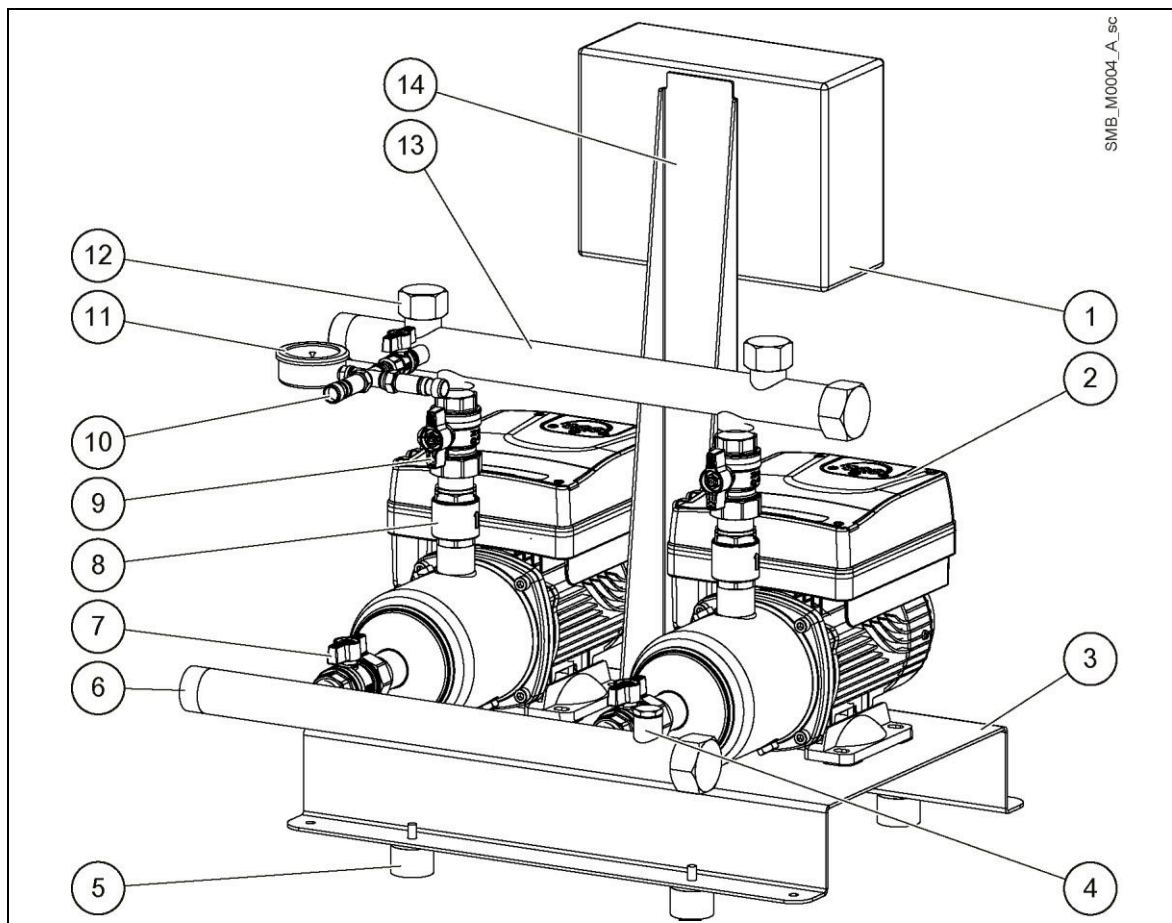

Figure 5: Booster set

Position number	Description	Q.ty
1.	Distribution panel	1
2.	E series pump units (e-SM units)	n
3.	Base	1
4.	Priming connection	1
5.	Anti-vibration foot	2 x n
6.	Suction manifold	1
7.	On-off valve on suction line	n
8.	Non-return valve	n
9.	On-off valve on delivery line	n
10.	Pressure sensor	n
11.	Pressure gauge	1
12.	Diaphragm pressure tank connection	1/2/3
13.	Delivery manifold	1
14.	Mounting bracket	1

Frequency converter

Refer to the Installation, Operation and Maintenance Manual of the pump units in the Smart Pump Range.

3.4 Intended use

The product can be used to pump:

- Cold water
- Hot water

Always observe the limits indicated in the Technical Data chapter.

The variable speed pump units installed in the SMB booster sets are suitable for the following applications:

- Pressure, level, and flow regulation (open loop systems)
- Single or multi pump unit irrigation systems.

3.4.1 Application alternatives

Actuator (constant speed)

The unit operates as an actuator according to speed set point; this is done through user interface, the corresponding analog input or the communication bus.

Controller (constant pressure)

This mode is set as the default operating mode, and is used for units that run with a single pump unit.

Cascade serial / Cascade synchronous

The units are connected via the RS485 interface and communicate via the provided protocol. The combination of the different units which are used in a multi-pump system depends on the system requirements.

It is possible to run all the pump units in cascade serial mode (default mode for multi pump systems) and synchronous mode as well. If one unit fails, then each pump unit of the booster set can become the lead pump unit and can take control.

3.5 Improper use

The product must not be used in closed circuit systems where the difference in pressure between two points of the system, generally the delivery and suction of the booster set, is controlled by two sensors for the purpose of keeping it constant.



4 Installation

4.1 Mechanical installation

4.1.1 Installation area



DANGER: Potentially explosive atmosphere hazard

The operation of the booster set in environments with potentially explosive atmospheres or with combustible dusts (e.g.: wood dust, flour, sugars and grains) is strictly forbidden.



WARNING:

- Always wear personal protective equipment
 - Always use suitable working tools
 - When selecting the place of installation and connecting the unit to the hydraulic and electric power supplies, strictly comply with current regulations.
 - Ensure that the ingress protection rating of the unit (IP 55, type 1) is suitable for the installation environment.
-



CAUTION:

- Input protection: to ensure the IP55 (type 1) protection index make sure that the unit is closed correctly.
 - Before opening the terminal box cover, make sure that there is no water in the unit
 - Make sure that all unused cable glands and cable holes are correctly sealed
 - Make sure that the plastic cover is correctly closed
 - Do not leave the terminal box without cover: risk of damage due to contamination
 - Make sure that the electric panel is correctly closed.
-

Outdoor installation of the booster set

In case of outdoor installation of the booster set, ensure appropriate cover (see example in Figure 6). The size of the cover must be such as to ensure protection of the booster set against snow, rain and direct sunlight.

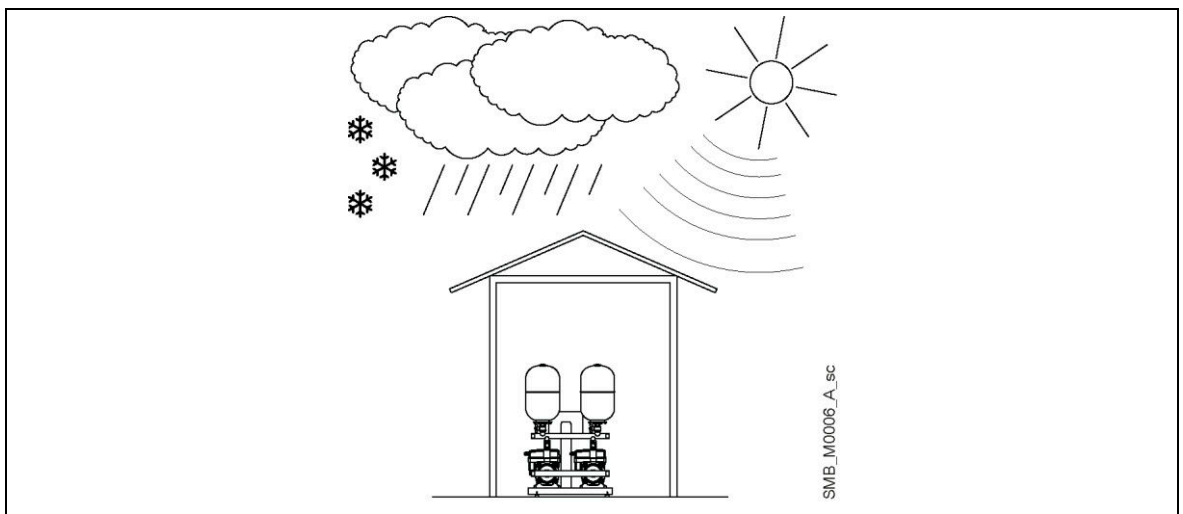

Figure 6: Outdoor installation of the booster set

4.1.2 Guidelines for mechanical installation

- The arrows on the pump unit body indicate the flow and the rotation direction of the motor
- The standard rotation direction of the motor is clockwise (looking at the fan cover)
- Install the booster set in a well ventilated room, leaving sufficient clearance (at least 0.5 m) on each side and at the front for the purpose of maintenance; there should also be a clearance of 0.5 m above the highest part of the booster set
- Place the booster set on a flat and solid surface, without fixing it down
- Mount expansion joints and suitable supports for the pipes to protect these against stress, see Figure 7. The weight of the pipes and pressure tanks increases when they are filled with water. Before starting the set, make sure you have closed and tightened all the unused couplings.

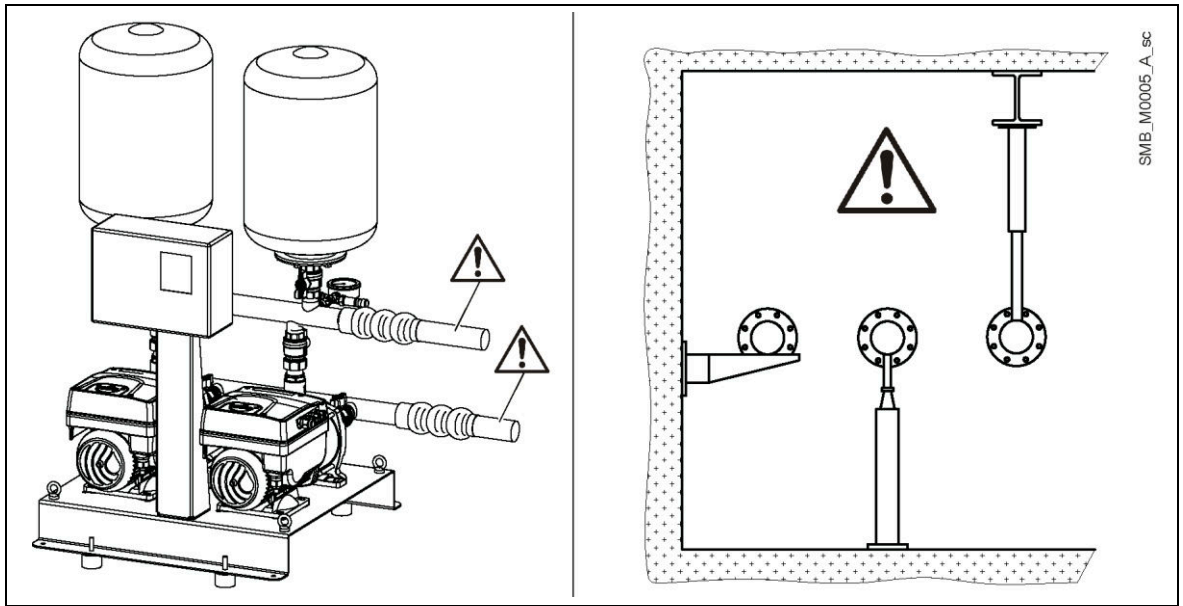

Figure 7: Mechanical installation of the booster set

4.2 Hydraulic installation

Figure 8 and 9 show a single pump system and a multi-pump system respectively.

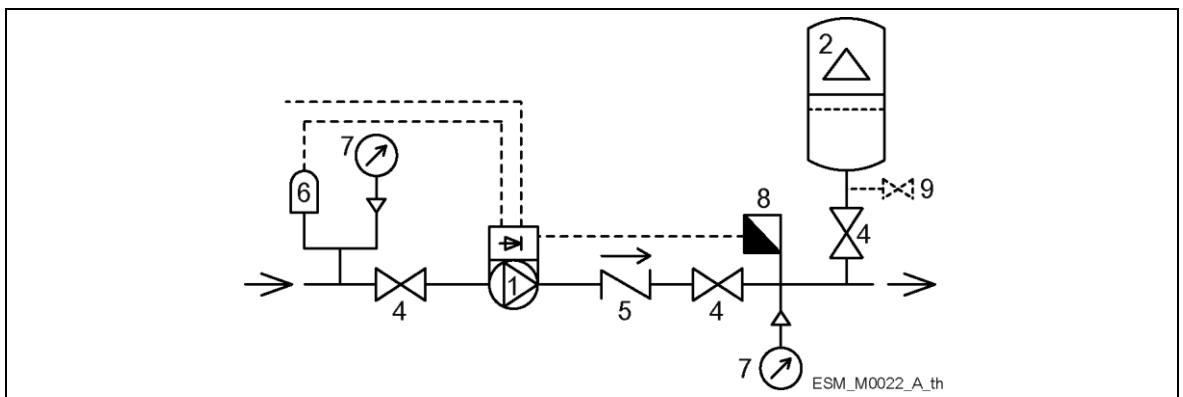

Figure 8: Single pump unit system

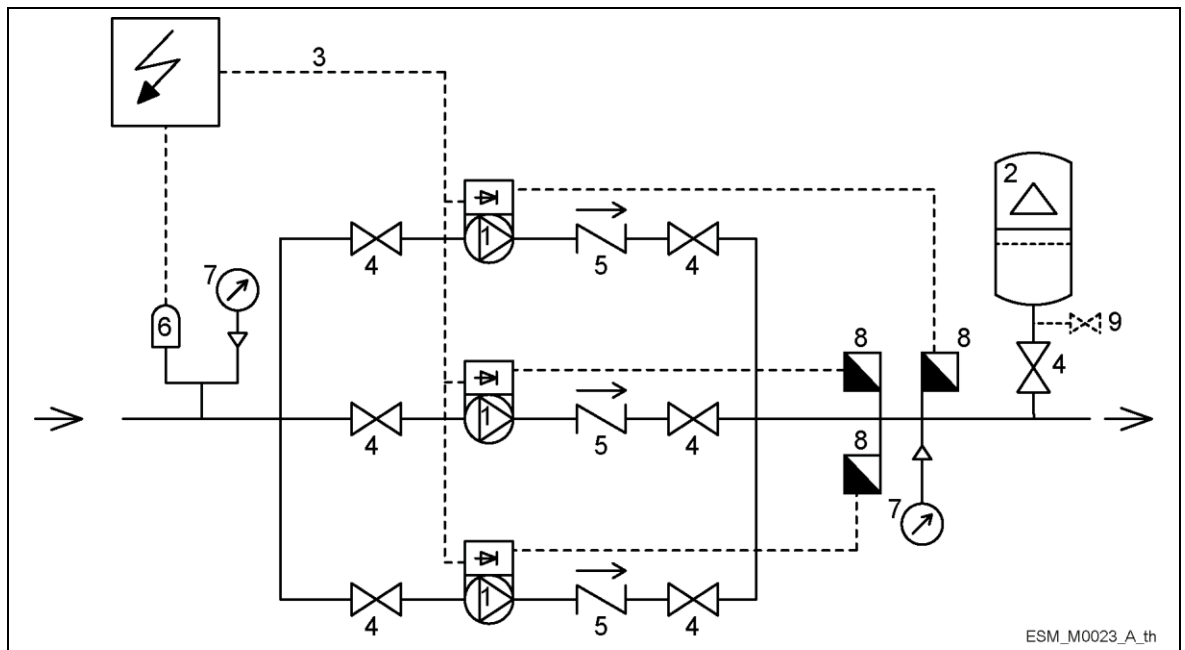

Figure 9: Multi-pump system

- | | | |
|------------------------------|----------------------|--------------------|
| 1. e-SM pump unit with motor | 4. On-off valve | 7. Pressure gauge |
| 2. Diaphragm pressure tank | 5. Non-return valve | 8. Pressure sensor |
| 3. Distribution panel | 6. Low water control | 9. Drain tap |

4.2.1 Guidelines for hydraulic installation

- Install the booster set according to the water flow rate of the system
- The arrows on the body of the pump unit indicate the flow and the rotation direction
- Install a foot check valve in case of a suction lift system
- Install an on-off valve immediately downstream of the booster set
- Install a drain valve for the tests if there is no valve next to the booster set
- The pipes connected to the booster set must be adequately sized (if possible, according to manifold diameter). You can use either end of the manifold, but don't forget to plug the unused end.
- The size of the suction pipe and foot check valve must be such as to avoid excessive load loss and the cavitation phenomena that can be caused as a result

Diaphragm pressure tank

On the delivery side of the pump unit there is a membrane expansion vessel, which gives the possibility of maintaining the pressure inside the piping when the booster set is not being used. The diaphragm pressure tank stops the pump unit from continuing to run at zero demand and reduces the size of the tank that is required for supply purposes.

Choose a diaphragm pressure tank suited to the pressure of the system.

Variable speed booster sets can operate with diaphragm pressure tanks of smaller sizes than traditional systems. A diaphragm pressure tank with a capacity in litres equivalent to about 10% the flow rate of a single pump unit, expressed in litres per minute. The volume of water required can be distributed between several tanks.

4.3 Electrical Installation



DANGER: Electrical hazard

The connection to the electric power supply must be completed by an electrician possessing the technical-professional requirements outlined in the current regulations.

For the electrical connections, refer to the wiring diagram in the control panel.

4.3.1 Electrical requirements

Local directives prevail on the specific requirements indicated below.

4.3.2 Electrical connection checklist

Check that the following requirements are met:

- The electrical leads are protected from high temperature, vibrations, and collisions.
- The current and voltage of the mains power supply must be compatible with the data on the plate of the control panel, or the data on the plate of the pump unit in the case of booster sets without control panel.
- Check that the power supply cable is capable of carrying the nominal current of the booster set, and connect it to the relevant terminals of the control panel. The wiring diagram and the labels on the panel provide the necessary information for connection and the required power supply values. For booster sets without control panel, refer to the Installation, Operation and Maintenance Manual of the pump units in the Smart Pump Range.
- If there is a control panel, connect the power cable:
 - Single-phase version to the L-N terminals, PE to the ground terminal
 - Single-phase version to the L1, L2 and L3 terminals, PE to the ground terminal
- Any exposed cables must be protected in an appropriate way
- The power supply line is provided with:
 - A high-sensitivity differential switch (30 mA) [residual current device RCD] suitable for earth fault currents with DC or pulsating DC content (a Type B RCD is suggested).
 - A mains isolator switch with a contact gap of at least 3 mm.

4.3.3 Electrical control panel check-list

NOTICE:

The standard version of the booster set has a control panel.

If the booster set is supplied without a control panel, install a control panel that is compatible with the ratings of the pump unit.

Inappropriate combinations do not guarantee the protection of the booster set.

Check that the following requirements are met:

- The control panel must protect the pump unit against short-circuit. A time lag fuse or a circuit breaker (Type C model is suggested) can be used to protect the pump unit.
 - The pump unit has built in overload and thermal protection. No additional overload protection is required.
-



DANGER: Electrical hazard

Before starting the pressure booster, make sure that the booster set and the control panel are isolated from the power supply and cannot be energized.

Grounding (earthing)



DANGER: Electrical hazard

- Always connect the external protection conductor to the ground terminal before attempting to make any other electrical connections
 - All the electrical equipment must be grounded (earthed); this includes the booster set and its equipment. Check that the ground terminal is connected properly.
 - Check that the protection conductor (ground) is longer than the phase conductors; in case of accidental disconnection of the power supply conductor, the protection conductor (ground) must be the last one to detach itself from the terminal.
-
- Keep the connections to the ground cable as short as possible.
 - Use a cable with several strands to reduce electric noise.

4.3.4 Wire types and ratings

For the standard version with control panel, the booster set is supplied with the power cables of the pump unit and the control cables. The booster set without control panel is supplied with the cable for connecting the pressure sensor but without the power cables of the pump unit. If the power cable of the pump unit and/or the control cables need to be replaced or added, refer to the Installation, Operation and Maintenance Manual of the pump units in the Smart Pump Range.

- All cables must comply with local and national standards in terms of section and ambient temperature
- Use cables with a minimum heat resistance of +70°C (158°F)
- Cables must never enter into contact with the motor body, the pump unit and the piping.
- The wires connected to the power supply terminals and the fault signal relay (NO, C) must be separated from the others by means of reinforced insulation.

Power supply connection



WARNING:

- Do not make any connection to the terminal board box of the pump unit without first disconnecting the power supply and waiting for the minimum time in Table 1.
- The standard version of the booster set is supplied with the power cables of the motor. Replace the power cable of the motor, if necessary, with a cable of a cross-section suited to the maximum consumption of the electric motor.

Control cables

External volt free contacts must be suitable for switching < 10 VDC.

NOTICE:

- Install the control cables separate from the power supply cables and the fault signal relay cable
- If the control cables are installed in parallel with the power supply cable or the fault signal relay, the distance between the cables must exceed 200 mm
- Do not intersect the power supply cables; should this be necessary, a 90° intersection angle is permitted.

Connecting the control panel

Refer to the wiring diagram in the control panel.

Connecting the frequency converter

Refer to the Installation, Operation and Maintenance Manual of the pump units in the Smart Pump Range.

4.3.5 Protection against dry running

The standard control panel can be connected to a common float for the open tanks, or to a minimum pressure pressure switch on the suction side (recommended value: 0.2-0.4 bar). When the minimum pressure conditions are restored, the pump units start automatically. If the dry running protection is considered to be superfluous, do not remove the jumper on the terminal in the control panel. The correct numbers of the terminals are given in the connection diagram that can be found in the control panel.

NOTICE:

The booster set is supplied with the jumper installed and, therefore, without the dry running protection enabled.

The optional electronic level control kit permits control with electrode probes. Install the three probes supplied with the kit in the collection tank and connect them to the terminals in the control panel.

The correct numbers of the terminals are given in the wiring diagram that can be found in the panel:

- Max probe (A) determines the level at which to activate the booster set during filling of the collection tank.
- Min probe (B) determines the level at which to deactivate the booster set.
- Probe (C) must be at a level below that of the Min probe (B).

5 Use and operation



In case of co-existence of two or more of the following conditions:

- high ambient temperature
- high water temperature
- duty points insisting on maximum power of the booster set
- persisting undervoltage of mains,

the life of the booster set may be jeopardised and/or derating may occur: for further information contact Xylem or the Authorised Distributor.

5.1 Wait times



WARNING: Electrical hazard

Contact with electric components may cause death, even after the booster set has been switched off. Before any interventions on the booster set, the network voltage and any other input voltages must be disconnected for the minimum time indicated in Table 1.

Table 1: Wait times

e-SM Drive model	Minimum waiting times [min]
103, 105, 107, 111, 115	4
303, 305, 307, 311, 315, 322	5



WARNING: Electrical hazard

Frequency converters contain DC-link capacitors that can remain charged even when the frequency converter is not powered.

To avoid electrical hazards:

- Disconnect the AC power supply
- Disconnect all types of permanent magnet motors
- Disconnect all DC-link remote power supplies, including the battery backups, the Uninterrupted Power Supply units and the DC-link connections to other frequency converters
- Wait for the capacitors to discharge completely before carrying out any maintenance or repairs; see Table 1 for the waiting times.

5.2 Starting and stopping

Starting and stopping of the pump units depends on the settings of the frequency converter in relation to the pump unit that is to be controlled (pressure, level).

Each frequency converter is connected to a sensor. The frequency converters share all the information and implement cycled switching.



Electrical hazard:

Disconnect the power supply before making any adjustments.

For the settings, refer to the Installation, Operation and Maintenance Manual of the pump units in the Smart Pump Range.

Figure 10 shows the operating curves in the case of two pump units in pressure adjustment mode.

- The tank supplies water to meet the demand of the final user.
- The first pump unit starts when the pressure drops below the PS value; the speed is adjusted to keep the pressure constant as demand increases.
- When demand decreases, the speed is reduced to minimum; at this point, one of the pump units is deactivated.
- If demand continues to increase and the pump unit reaches maximum speed, the second pump unit is started and the speed is adjusted to maintain constant pressure.
- If demand decreases further, the pump unit slows down, fills the tank and then stops when the PS value is reached.

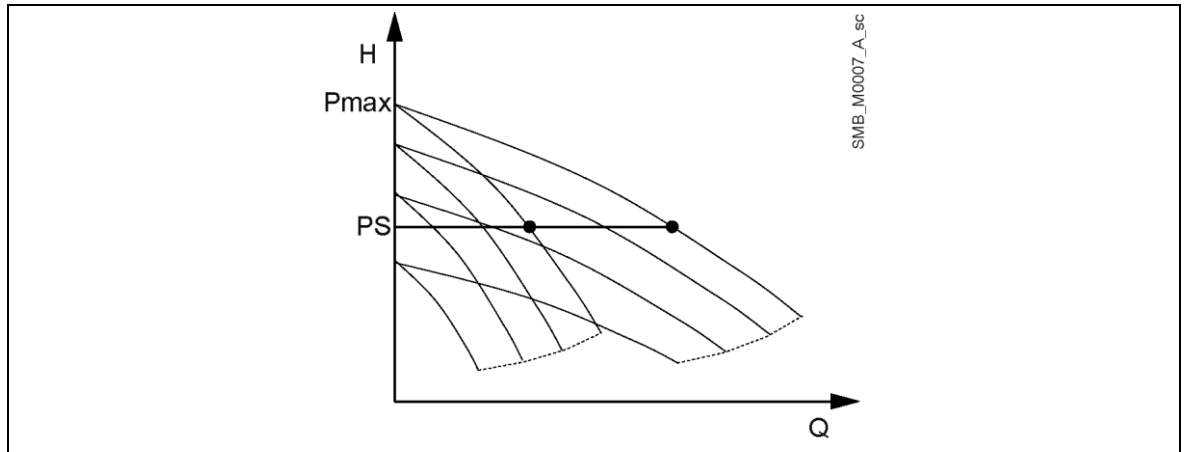

Figure 10: Operating mode

H	Head	Pmax	Maximum pressure
Q	Flow	PS	Pressure setting value

5.2.1 Adjusting the frequency converter

1. To change the settings, refer to the Installation, Operation and Maintenance Manual of the pump units in the Smart Pump Range.
2. Use the buttons of the frequency converter to set a new pressure adjustment value, select the time of the ramps, check the latest alarms or access all the settings.
3. Check that the new selected value is within the range of the head specified on the data plate of the pump unit.

5.2.2 Pre-charging the diaphragm pressure tank

1. Check that the diaphragm pressure tank is completely drained.
2. Pre-charge the diaphragm pressure tank at 0.6 times the pressure value.

5.2.3 Starting the booster set

1. Connect the water supply.
2. Connect the power supply.
3. Check the pre-charge value of the diaphragm pressure tank.
4. Shut the on-off valves located on the delivery line of the pump unit.
5. Prime the booster set (refer to the Installation, Operation and Maintenance Manual of the pump units in the Smart Pump Range) and the suction manifold.
6. Connect the power supply at the panel switch and set the frequency converter to manual mode.
7. Start the first pump unit.
8. Open the pump unit delivery on-off valve slowly and bleed the air.
9. Repeat the above operations for the other pump units.
10. Set the frequency converters to automatic mode.

How to change the settings

With the booster set running, follow the instructions below on how to change the settings within the maximum pressure limits of the pump units or system or both:

1. Establish the required pressure value.
2. Set the new value using the buttons of the frequency converter; the value is automatically changed also for the other converter.

6 Maintenance



DANGER: Electrical hazard

- Before attempting to use the unit, check that it is unplugged and that the pump unit and the control panel cannot restart, even unintentionally. This also applies to the auxiliary control circuit of the pump unit.
 - Before any interventions on the booster set, the network power supply and any other input voltages must be disconnected for the minimum time indicated in the para. Wait Times (the capacitors of the intermediate circuit must be discharged by the built-in discharge resistors).
-

1. Make sure that the cooling fan and the vents are free from dust.
2. Make sure that the ambient temperature is correct according to the limits of the booster set.
3. Make sure that qualified personnel perform all modifications of the booster set.
4. Make sure that the booster set is disconnected from the power supply before any work is carried out.
5. Always observe the pump unit and motor instructions.

6.1 Maintenance of the control panel and frequency converters

The control panel and frequency converters do not require maintenance.

6.2 Maintenance of the diaphragm pressure tank

- Refer to the Installation, Operation and Maintenance Manual of the diaphragm pressure tank
- Check the pre-charge at least once a year.

Function and parameter control

In case of changes to the hydraulic booster set:

1. Make sure that all functions and parameters are correct.
2. Adjust the functions and parameters if necessary.

7 Troubleshooting



Precautions



WARNING:

- Faults must be corrected by a technician possessing the technical-professional requirements outlined in the current regulations
- Observe the safety requirements in the chapters on Use and Operation and Maintenance
- If a fault cannot be corrected or is not mentioned, contact Xylem or the Authorised Distributor.

The frequency converter saves the last alarms that have occurred. Refer to the instructions on use of the frequency converter for the types of fault and how to check the last alarms that have occurred.

7.1 The booster set is off

Cause	Remedy
Power supply cut off	Restore the power supply
Switch in OFF position	Turn the switch ON

7.2 Motor does not start

Cause	Remedy
Power supply cut off	Restore the power supply
The thermal overload protection of the motor has been triggered	Eliminate the fault and reset the switch
Motor (coil) faulty	Check and repair or replace the motor

7.3 Frequent start-ups and stops

Cause	Remedy
Diaphragm pressure tank faulty	Repair or replace the diaphragm pressure tank
Incorrect pre-charge of the diaphragm pressure tank	Set the new pressure pre-charge value according to the pump unit and setpoint
The pre-charge value of the diaphragm pressure tank is at zero	The diaphragm pressure tank must be pre-charged

7.4 The speed of the pump unit increases and decreases without stopping and without consumption of water (utility closed)

Cause	Remedy
Loss of water from the non-return valve	Check the hydraulic system and the valve
The diaphragm pressure tank is damaged or undersized	Repair or replace the diaphragm pressure tank

7.5 The motor runs but no water is delivered

Cause	Remedy
No water on suction side or inside the pump unit	1. Fill (prime) the pump unit or suction pipe 2. Open the on-off valves
Air inside the suction pipe or pump unit	1. Vent the pump unit 2. Check the suction connections
Loss of pressure on the suction side	Check the NPSH and, if necessary, modify the system
Non-return valve blocked	Clean the valve
Clogged pipe	Clean the pipe

7.6 Loss of water from the pump unit

Cause	Remedy
Mechanical seal worn or damaged	Replace the mechanical seal
Undue mechanical stress on the pump unit	Support the pipes

7.7 Too noisy

Cause	Remedy
Return of water when the pump unit is not running	Check the non-return valve
Cavitation	Check suction
Rotation of pump unit hindered	Check for undue mechanical stress on the pump unit

7.8 The booster set does not generate the required pressure

Cause	Remedy
On-off valves closed	Open the valves
Air in the suction pipe	1. Eliminate the air 2. Prime the pump units
Excessive negative suction head	Decrease the negative suction head
Excessive loss of pressure on the suction side	Increase the diameter of the pipes
Foot check valve damaged	Replace the foot valve
Excessive loss of pressure in the delivery pipes and/or in the valve	Reduce the loss of water

7.9 Tripping of the main protection system (fuses)

Cause	Remedy
Short circuit	1. Check the connecting cables 2. Check the frequency converter

7.10 Tripping of the differential protection

Cause	Remedy
Damaged motor	Replace the motor
Power cable of the motor faulty or worn	Replace the cable
Differential switch not compliant with the specifications	Replace the differential switch
Differential current too high	Contact a qualified technician to have the electrical system modified

7.11 The pump unit runs at maximum speed without stopping

Cause	Remedy
Pressure setpoint not suitable for the system (the value is higher than the pressure that the pump unit can deliver)	Set the new setpoint according to the performance of the pump unit
Sensor not connected or damaged	Check the hydraulic and electrical connection of the sensor

7.12 Only one pump unit is running

Cause	Remedy
The pump units have different settings	<ol style="list-style-type: none"> 1. Check setting of the frequency converter 2. Check the serial connection between the two frequency converters

7.13 There is demand for water but the pump unit does not start

Cause	Remedy
The setpoint is set at zero	<ol style="list-style-type: none"> 1. Check setting of the frequency converter 2. Set the setpoint

8 Technical Data



Table 2: Electrical, environmental and installation specifications, booster set in standard version

	Model of booster set		
	M2	T3	T4
Control panel power supply	M2	T3	T4
Input			
Input frequency [Hz]	50/60 ± 2		
Main supply	LN	L1 L2 L3	
Nominal input voltage of the control panel [V]	230 ± 10%	230 ± 10%	400 ± 10%
Max. Input Current Continuous [A]	Refer to the data plate of the control panel		
Max power of control panel [kW]	Refer to the data plate of the control panel		
Output			
Min-max speed for pump unit [rpm]	800 to 3600		
Leakage current for inverter [mA]	< 3,5		
I/O auxiliar + 15VDC power supply [mA]	I _{max} < 40		
Fault signal relay	1 x NO V _{max} < 250 [VAC], I _{max} < 2 [A]	1 x NO V _{max} < 250 [VAC], I _{max} < 2 [A]	
Motor status relay	-	1 x NO V _{max} < 250 [VAC], I _{max} < 2 [A]	
Sound pressure L _{pA} [dB(A)] @ [rpm]	<62 @3000 <66 @3600		
Protection class	IP 55, Enclosure Type 1 Protect the product from direct sunlight and rainfall		
Water temperature [°C] / [°F]	0÷80 / 32÷176		
Relative humidity in relation to the operating temperature [°C] / [°F]	5% - 50% RH @ 40 / 104 5% - 90% RH @ 20 / 68		
Relative humidity for storage	5% ÷ 95% RH		
Storage temperature [°C] / [°F]	-25÷65 / -13÷149		
Operating temperature [°C] / [°F]	-20÷40 / -4÷104		
Installation altitude a.s.l. [m] / [ft]	< 1000 / 3280 Derating may occur at higher altitudes		
Max operating pressure [bar]	8, 10 or 16, depending on the type of pump unit. Refer to the Installation, Operation and Maintenance Manual of the pump unit in the Smart Pump Range.		
Min inlet pressure [bar]	According to NPSH curve with a margin of at least 0.5 m for air-free water		
Max inlet pressure [bar]	Make sure the inlet pressure plus the closed delivery pressure does not exceed the maximum operating pressure		
General data of the pump unit	Refer to the Installation, Operation and Maintenance Manual of the pump unit in the Smart Pump Range		
Diaphragm pressure tank [bar]	Refer to the standard Installation, Operation and Maintenance Manual of the diaphragm pressure tank. Installed diaphragm pressure tanks can limit the temperature and operating pressure of the booster set		

8.1 Dimensions and weights

- Booster set: refer to the technical catalogue or contact Xylem or the Authorised Distributor.
- Pump units in the Smart Pump Range: refer to the Installation, Operation and Maintenance Manual.

9 Declarations

9.1 EC Declaration of Conformity (Original)

Xylem Service Italia S.r.l., with headquarters in Via Vittorio Lombardi 14 - 36075 Montecchio Maggiore VI - Italy, hereby declares that the product:

Pumping unit with pump units with integrated variable speed drive (refer to label on first page)

fulfils the relevant provisions of the following European Directives:

- Machinery 2006/42/EC (ANNEX II - natural or legal person authorised to compile the technical file: Xylem Service Italia S.r.l.)

and the following technical standards

- EN 809:1998+A1:2009,
- EN 60204-1:2006+A1:2009

Montecchio Maggiore, 22/02/2017

Amedeo Valente
(Director of Engineering and
Research & Development)
rev.00



9.2 EU Declaration of Conformity (No EMCD23)

1. Apparatus model/Product:
see adhesive on the first page
2. Name and address of the manufacturer:
Xylem Service Italia S.r.l.
Via Vittorio Lombardi 14
36075 Montecchio Maggiore VI
Italy
3. This declaration of conformity is issued under the sole responsibility of the manufacturer.
4. Object of the declaration:
Pumping unit with pump units with integrated variable speed drive (refer to label on first page)
5. The object of the declaration described above is in conformity with the relevant Union harmonisation legislation:
Directive 2014/30/EU of 26 February 2014 (electromagnetic compatibility)
6. References to the relevant harmonised standards used or references to the other technical specifications, in relation to which conformity is declared:
EN 61000-6-2:2006, EN 61000-6-3:2007+A1:2011
7. Notified body: -
8. Additional information:

Signed for and on behalf of: Xylem Service Italia S.r.l.
Montecchio Maggiore, 22/02/2017
Amedeo Valente
(Director of Engineering and
Research & Development)
rev.00



Lowara is a trademark of Xylem Inc. or one of its subsidiaries.

Xylem Service Italia S.r.l.
Via Vittorio Lombardi 14
36075 – Montecchio Maggiore (VI) - Italy
www.xylem.com/brands/lowara

