

# SMB10 - SMB20 - SMB30 Series

VARIABLE SPEED BOOSTER SETS WITH e-SM DRIVE

VERTICAL MULTISTAGE ELECTRIC PUMPS SERIES e-SV™ SMART

HORIZONTAL MULTISTAGE ELECTRIC PUMPS SERIES e-HM SMART

Lowara, e-SV, HYDROVAR, Xylect are trademarks of Xylem Inc. or one of its subsidiaries.  
All other trademarks of registered trademarks are property of their respective owners.

## CONTENTS

GENERAL INTRODUCTION – PRODUCT DESCRIPTION .....	<b>4</b>
DESCRIPTION OF OPERATION .....	<b>5</b>
INSTALLATION.....	<b>7</b>
CHOICE AND SELECTION .....	<b>8</b>
<b>SMB10, SMB20, SMB30 SERIES.....</b>	<b>15</b>
ELECTRIC PUMP RANGE AND CHARACTERISTICS.....	<b>18</b>
HYDRAULIC PERFORMANCE TABLES .....	<b>27</b>
<b>SMB10 SERIES .....</b>	<b>47</b>
<b>SMB20 SERIES .....</b>	<b>52</b>
<b>SMB30 SERIES .....</b>	<b>67</b>
PERFORMANCE CURVES.....	<b>81</b>
H <sub>c</sub> PRESSURE DROP CURVE .....	<b>150</b>
ACCESSORIES.....	<b>153</b>
TECHNICAL APPENDIX.....	<b>159</b>

## **SMB BOOSTER SETS SERIES**

### **GENERAL INTRODUCTION – PRODUCT DESCRIPTION**

The variable speed SMB booster sets are designed for water transfer and pressurization in the following applications:

- Apartments, single and multi-family houses, condominiums and residential buildings
- Hotels, restaurants, spas
- Various industrial applications

**SMB** series booster set are variable speed pumping stations with one, two or three **e-SV Smart** series multistage vertical pumps or **e-HM Smart** series multistage horizontal pumps. Each pump is equipped with an e-SM frequency drive that ensures the variable speed operation on all electric pumps.

These types of systems improve the comfort of the end user, reducing noise emissions and also “water hammer”, thanks to the gradual switching off of the pumps.

**SMB10:** The pump is connected to a 5-way fitting by a non-return valve. Control panel is available as accessory.

**SMB20, SMB30:** The pumps are installed on a single base and connected to each other by means of suction and delivery pipes. The pumps are connected to the manifolds by means of on-off valves and non-return valves. The control panel is secured to the same base by means of a bracket.

**SMB series booster sets with e-SV Smart and e-HM Smart series pumps are certified for use with drinking water.**

SMB series booster sets are available with a wide range of electric pumps to satisfy the different needs of every system. SMB booster sets are also available in special versions to fit specific duty points and applications. Systems for regulating the speed of the electric motors, as in SMB series booster sets, are used in the following cases:

- In case of systems with a lot of users where the daily consumption varies frequently and in different periods.
- When it is necessary to obtain constant pressure.
- In the case of systems with supervision it is possible to monitor and check the performances of the booster sets.

## SMB BOOSTER SETS SERIES DESCRIPTION OF OPERATION

All the electric pumps are controlled by e-SM drive frequency converter and operate at variable speeds. Start-up is automatic, depending on system requirements. Each electric pump has a pressure transmitter that provides a pressure reading, which is recorded and sent to the frequency converter. The electric pump speed is modulated based on system requirements. Electric pump start alternation is automatic, following a preset time (parameter available in the frequency converter). Electric pump starts and stops are determined based on the pressures entered as set values in the menu of the frequency converter.

### Example operation of a set of three electric pumps.

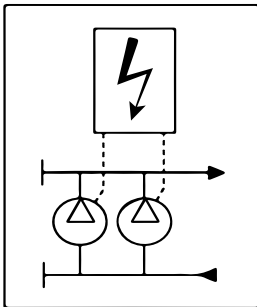

Each electric pump is controlled by a frequency converter. The starting priority is changed in accordance with the time set in the relevant parameter field on frequency converter. The speed adjustment will apply to all the electric pumps installed. When the water request decreases, the electric pumps stop in succession. The electric pumps connected to the frequency converter keep the pressure constant by modulating the number of motor revs. The acceleration and deceleration of the electric pump, both at start-up and switch off, is of the soft type. This helps to reduce water hammer and ensures a quiet operation of the booster set.

Lowara SMB series booster sets guarantee constant pressure of the system as in the following example:

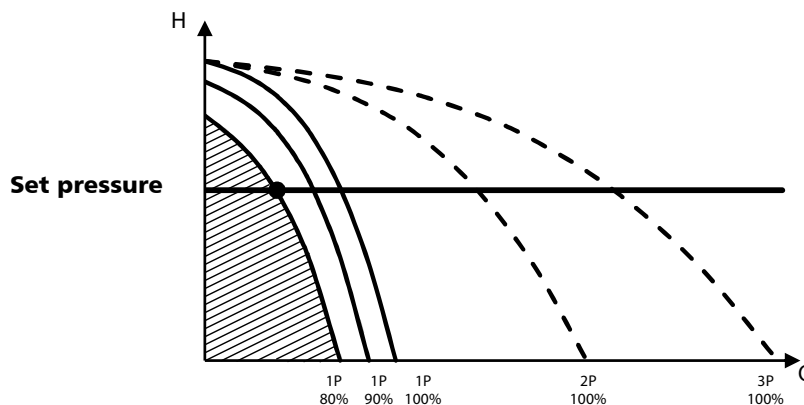

### Example: multistage vertical electric pumps e-SV Smart series

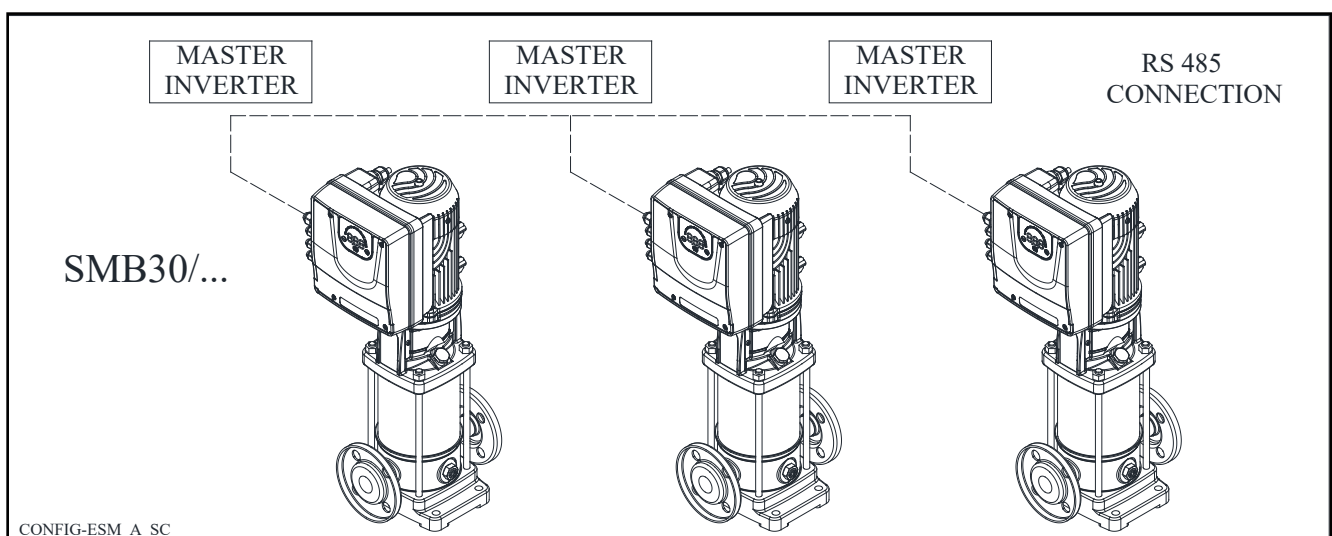

## SMB BOOSTER SETS SERIES DESCRIPTION OF OPERATION

When the pressure decreases, an electric pump starts, adjusting the motor speed so that the set pressure value can be guaranteed. When the demand for water increases, the other electric pumps also start in sequence, at variable speed, to keep the pressure at a constant level.

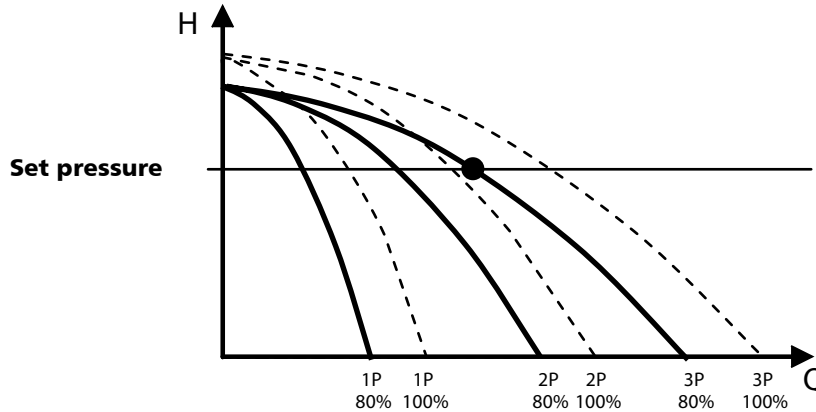

When the demand for water decreases, the electric pumps switch off in succession. The number of revolutions of the first electric pump switched on decreases to a set minimum before switching off.

### Regulating the constant pressure value

SMB series booster sets guarantee constant pressure of the system even during frequent variations in water consumption.

The system pressure value is measured by the pressure transducers connected to the delivery manifold.

The value found is compared with the set value. The comparison between the measured pressure and the set pressure is performed through the internal "controller" of frequency converter, which manages the motor speed acceleration and deceleration ramps (frequency), changing the performance of the electric pump during the time.

In case of fault of one of the frequency converters, the others will remain active and will continue to guarantee the control of the other electric pumps and the constant pressure.

### Type of control

SMB series booster sets use one or more sensors as a standard device to control pressure.

For each booster set, there are as many sensors as the number of electric pumps installed. In case of fault of one of the transducer, the converter connected to the electric pump stops working.

### Cyclical exchange of pumps

In the SMB series, electric pump start is alternated according to a time set for each pump, through a clock in the frequency converter menu.

### Additional protection against dry running

Protection against dry running activates when the water reserve falls below the minimum level guaranteed for suction. The level can be checked using a float switch, a minimum pressure switch, an external contact, or level probes. For the latter, the probes must be connected to the adjustable sensitivity electronic module.

The control panel is already preset for the installation of this module.

### Minimum delivery pressure protection

The minimum delivery pressure function can be managed by entering the pressure value in the menu of the frequency converter, which will receive the signal through the pressure transducer at the delivery.

## SMB BOOSTER SETS SERIES INSTALLATION

The booster sets must be installed in areas protected against frost and with adequate ventilation to cool the motors. It is a good practice to connect the booster set to the suction and delivery pipes of the system inserting vibration-damping joints to limit the transmission of vibrations and resonance to the system.

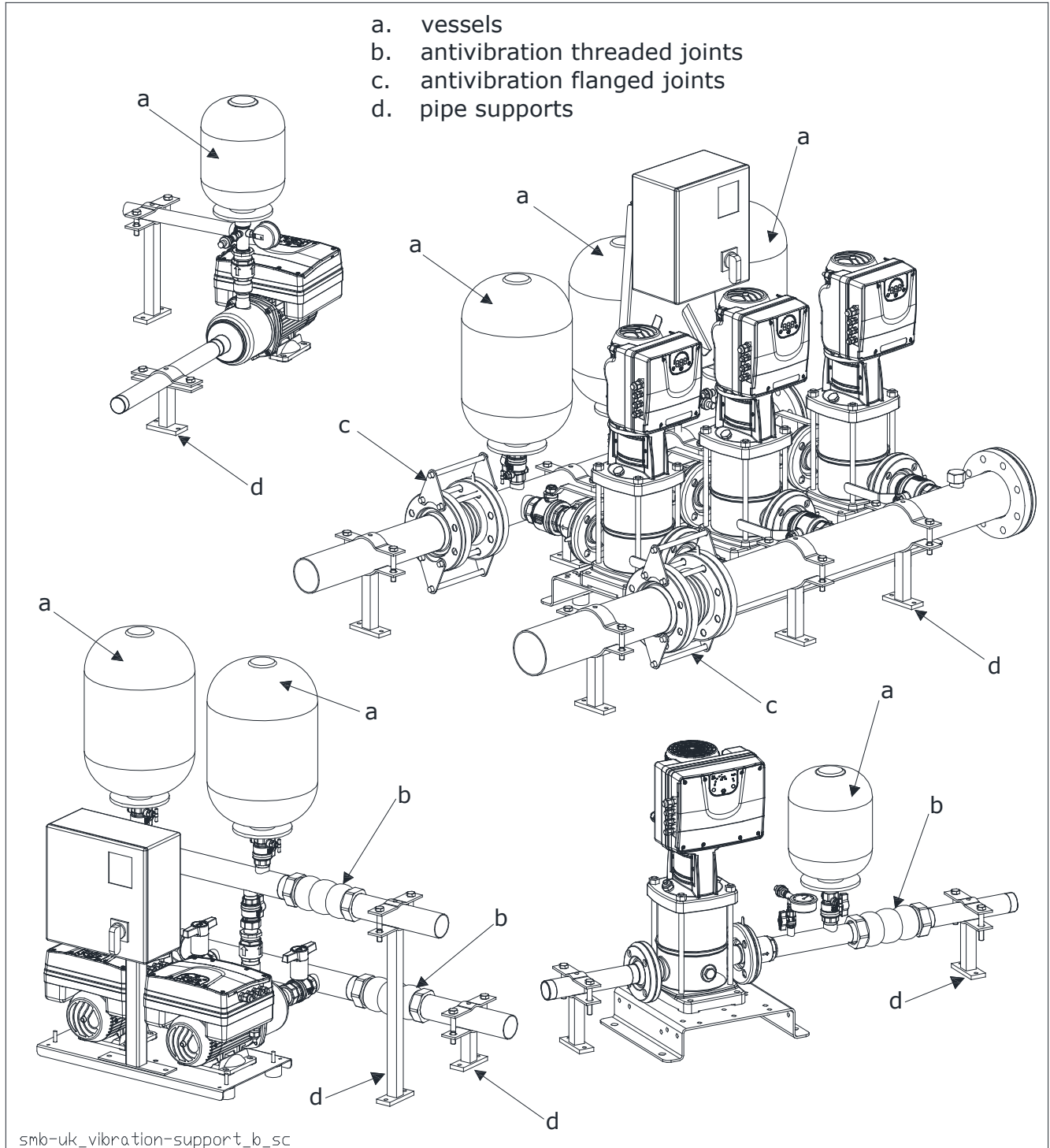

The booster set is connected to pressurised tanks.

These tanks can avoid any problems due to water hammer that is created due to the sudden stopping of the electric pumps running at a fixed speed. For this type of system, diaphragm expansion vessel (hydro tube) are installed in the delivery piping for perform a pressure dampening function.

Due to their design, variable-speed booster sets can satisfy users' demands by moderating the electric pump speed. Considering also that variable-pressure sets are very sensitive to swings of pressure in the system, the use of vessels allows the pressure to stabilise when requests are low or inexistent, and avoids the electric pumps remaining in operation at minimum speed without stopping.

## SMB BOOSTER SETS SERIES CHOICE AND SELECTION

The following conditions should be considered when choosing a booster set:

- The system's flow rate and pressure requirements should be met.
- The unit must not be oversized, avoiding unnecessary installation and running costs.

Generally water distribution systems such as those for domestic water supply or for large agglomerates such as hospitals, hotels or similar, have "variable" water consumption i.e. in a 24-hour period there may be sudden variations in consumption that are difficult to foresee. A pattern of consumption may occur in 24 hours, but the daily percentage of unit operation may also occur at various flow rates.

Generally the definition of flow rate for these types of systems is based on either the "probability calculation" which is a very complex system of calculation, or based on tables or diagrams in the national standards which provide guidelines for the sizing of the systems and therefore for calculating the maximum simultaneous flow rate.

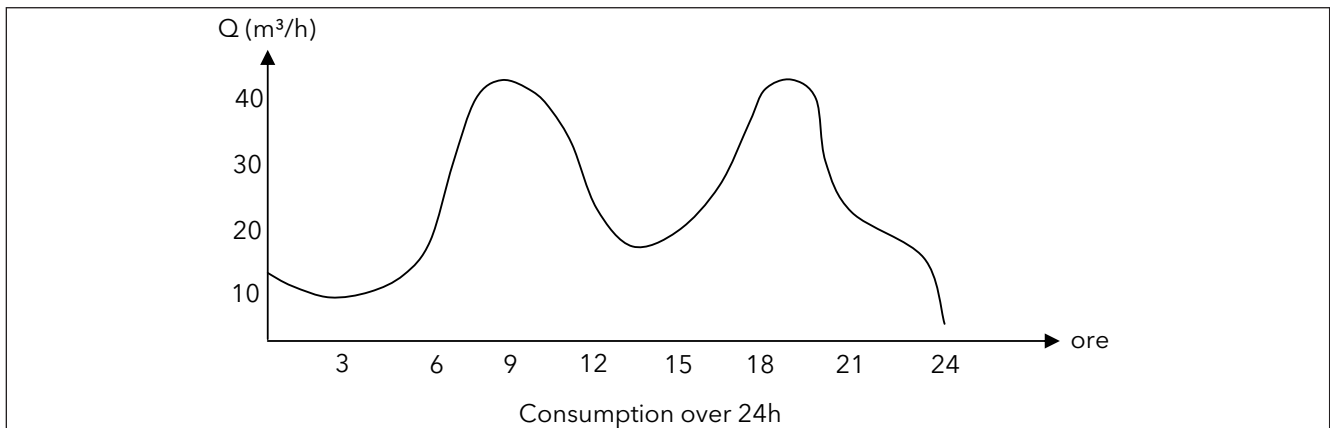

The operating time of the unit still calculated over 24h, gives us a view of the daily percentage of operation at the various flow rates.

This means that there may be daily peaks where the maximum flow rate requested is concentrated in a short space of time. In the example given below, it can be seen that in 100% of the time there is a consumption of 4 m<sup>3</sup>/h, while in 20% of the operating time there is a consumption of 40 m<sup>3</sup>/h.

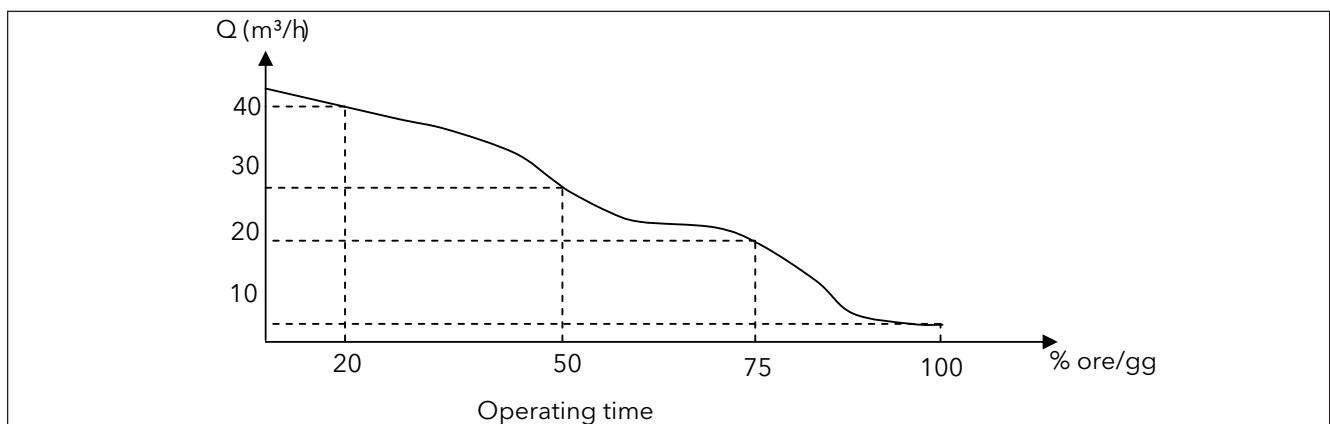

When selecting the booster set the consumption figure of the system must be considered, which is generally supplied by the person who designed the system. For systems where consumption varies continuously and suddenly over time it is advisable to install SMB series booster sets with variable regulation of the electric pump speed.

The calculation of the size of the booster set (its performance and the number of electric pumps) is based on the take-off point and therefore on the consumption value which takes the following factors into account:

- The value of the peak in consumption
- Efficiency
- NPSH
- Standby pumps
- Diaphragm tanks

## SMB BOOSTER SETS SERIES CHOICE AND SELECTION

By adjusting their operation over time, variable-speed booster sets give the end user energy savings which can be calculated directly on the control board with a metering module fitted in the electric control panel.

This allows checking of the system yield, especially in complex systems with many users and many ranges of consumption. It is possible to install a standby electric pump if it is necessary to have some kind of additional safety in the pump station. This is typical in systems of a certain importance, such as hospitals or factories, or in the field of crop irrigation.

SMB series booster sets must also be equipped with expansion vessels (for the size of the vessels, see the specific chapter in this catalogue). A single vessel or several smaller vessels can be installed on the delivery of the booster set, always taking the total capacity into account.

Expansion vessels avoid the risk of water hammer, which is harmful for both the system and the electric pumps.

Generally for systems with highly variable or sudden variations in consumption, it is recommended to install a booster set with variable electric pump speed, such as the SMB series, to guarantee constant pressure.

What type of electric pump to choose?

Generally, the selection of electric pump is based on the maximum duty point of the system, which is usually the highest possible. The maximum request value is normally for short periods, so the electric pump must also be able to satisfy variable requests throughout its time in service. Generally the choice of the electric pump, based on the performance curve, should fall around the maximum efficiency point. The pump must ensure operation within its rated performance.

Since the unit is sized according to the maximum possible consumption, the maximum duty point of the electric pumps must be in the area on the right of the performance curve so that, if there is a fall in consumption, the efficiency remains high.

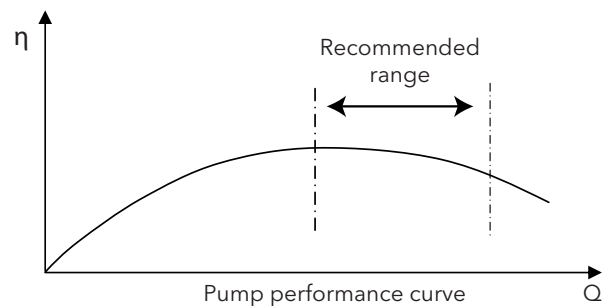

If we make a choice on the characteristic curve of the electric pump, we can see that the optimum working area where the booster works is represented by the following graph:

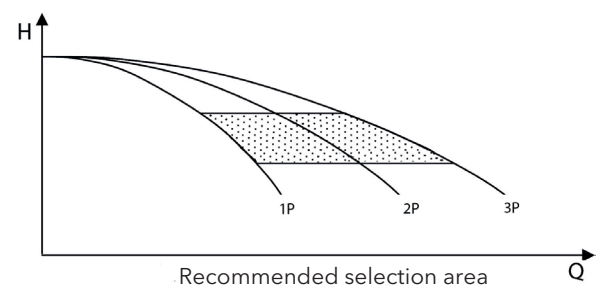

Another factor to be considered when choosing the electric pumps is its NPSH value. Never choose a electric pump where the maximum duty point is too far to the right of the NPSH curve. This risks not having good electric pump suction, which may be aggravated by the type of installation (where negative suction is possible). In these cases there is the risk of cavitation. The NPSH of the electric pump must always be checked at the maximum flow rate requested.

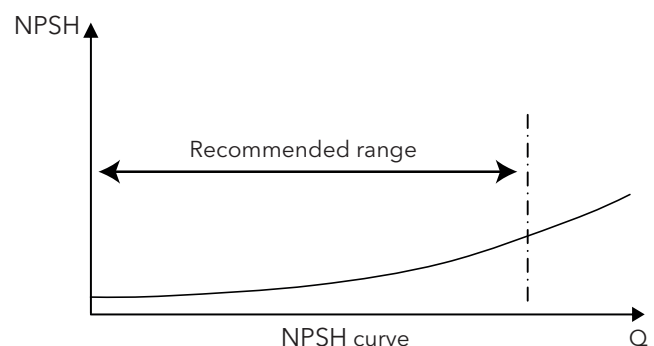

## SMB BOOSTER SETS SERIES HOW TO READ BOOSTER SETS WITH e-SM DRIVE CURVES

To exploit to the maximum potential of SMB BOOSTER SETS it's important to properly read working curves shown in the relevant charts.

① **Booster set model**

② **Maximum speed curve**

③ **Minimum speed curve:** it refers to the minimum rpm level the motor can work at, it's calculated depending on the model of pump maximizing for each one the working area and allowing the highest system flexibility.

④ The **area with dotted lines** is where the pump could only operate intermittently for short periods of time.

⑤ Each **intermediate curve** between max and min speed shows the percentage of load the system is working at **synchronous** mode (all pumps work at the same speed); it's easy to read also from the LED speed bar on the HMI keypad: at 90% there will be 9 led, at 80% there will be 8 and so on.  
Example: at 60% there will be 6 lit led's as in figure.

⑥ The **part load percentage** is calculated depending on maximum speed (max, 100%) and minimum speed (min, equal to 0%, which is the minimum part load step, below it the drive stays powered up but cannot work).

⑦ **NPSH:** is the net positive suction head of booster set with all pumps working at synchronous mode and at the maximum speed.

**Load control:** the booster set SMB series controls and limits power consumption at high flow/low head, in this way the motor stays protected from overload and ensure a longer life of pump+motor+drive system.

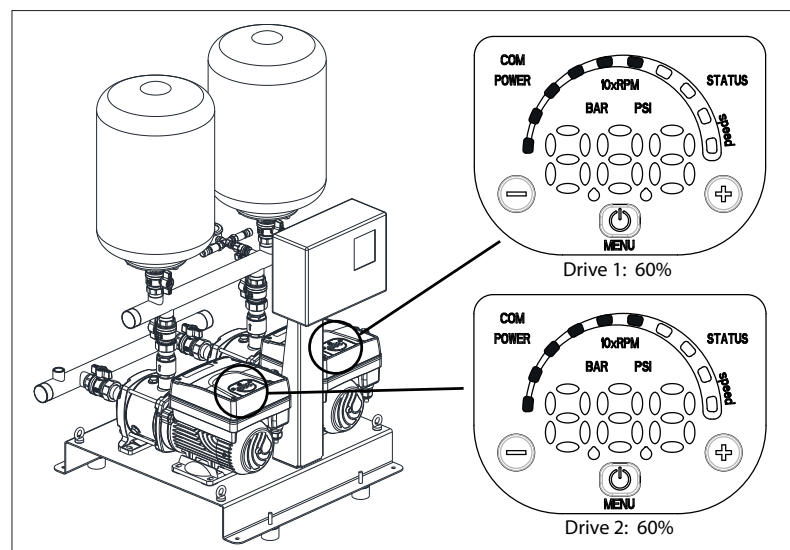
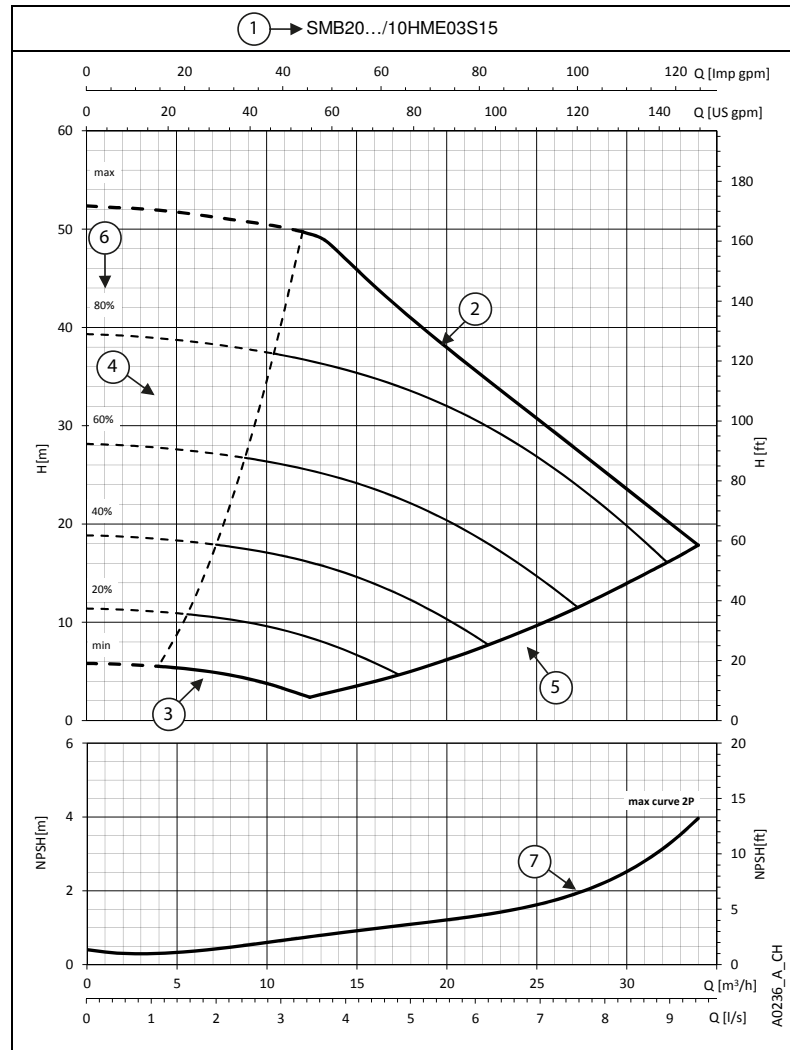

## SMB BOOSTER SETS SERIES SELECTING THE PUMPS

The choice of electric pump is therefore based on the characteristic curve of the electric pump depending on the flow rate and the pressure required for the system. Starting from the required flow rate, a vertical line is drawn until it meets the horizontal line of the required pressure. The point of intersection of the lines gives both the type and the number of electric pumps necessary for the system.

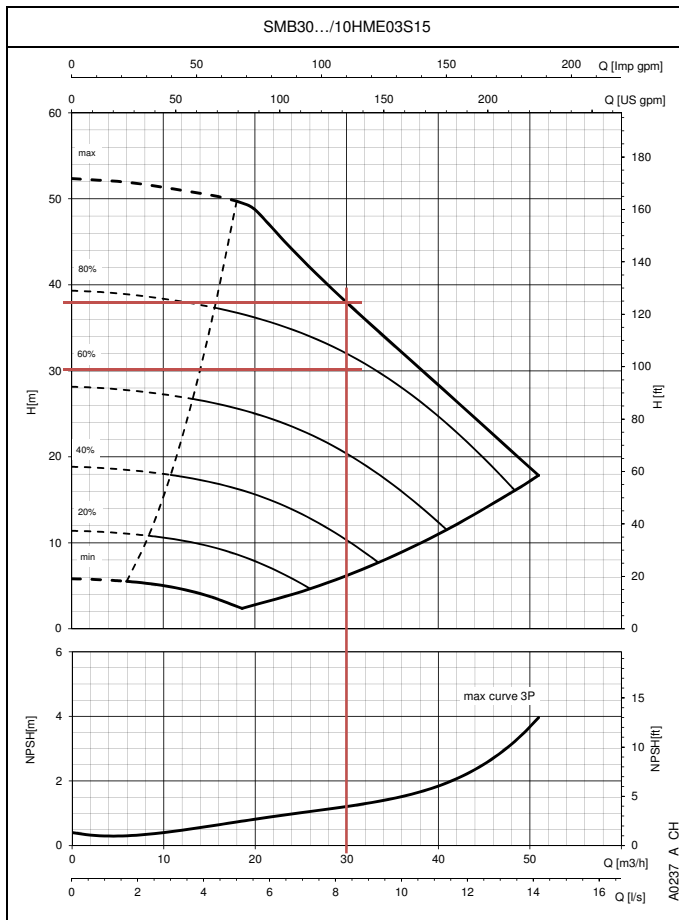

The example alongside refers to a required flow rate of 30 m<sup>3</sup>/h and a pressure of 30 m water column

As shown in the operating curves on page 145, the selection requires three 10HME03S15 electric pumps.

Moreover the take-off point falls in the npsH area farthest to the left and therefore in an area with a low cavitation risk.

The values obtained are those for the performance of the pumps. A correct check of the net pressure value must be made due to the intrinsic load loss of the booster set and the conditions of installation.

For this reason it is recommended to see the specific chapter in this catalogue.

### NPSH

The minimum operating values that can be reached by the pump suction are limited by the appearance of cavitation. Cavitation consists in the formation of steam pockets in the liquid when the local pressure reaches a critical value. A critical value is when the local pressure is equal or just below the pressure of the liquid steam.

Steam cavitation flows with the current. When it reaches a higher pressure area, condensation of the contained steam occurs. The pockets collide, causing pressure waves that are transmitted to the walls, which are therefore subjected to stress cycles that can cause deformation and then breaks due to fatigue. This phenomena, characterised by a metallic noise due to the hammering of the walls, is called incipient cavitation. Cavitation damage can be made worse by electrochemical corrosion, and by local temperature increases due to the plastic deformation of the walls.

The materials with the highest resistance to heat and corrosion are alloyed steels, and particularly austenitic steels. The conditions that cause cavitation can be predicted by calculating the total suction height, indicated in the technical literature with the acronym NPSH (Net Positive Suction Head).

The NPSH represents the total energy (in m) of the flow measured at the suction in incipient cavitation conditions, net of the steam pressure (in m) of the fluid at the input of the pump.

## SMB BOOSTER SETS SERIES SUCTION CONDITIONS

Once the type and the number of electric pumps of the set have been identified, the suction conditions must also be assessed. Below is an example of the assessment of the suction lift installation conditions, in relation to the previously described case: in suction lift installation, it is necessary to calculate the maximum Hg height which must not be exceeded due to safety reasons, to avoid cavitation, and therefore the unpriming of the pump itself.

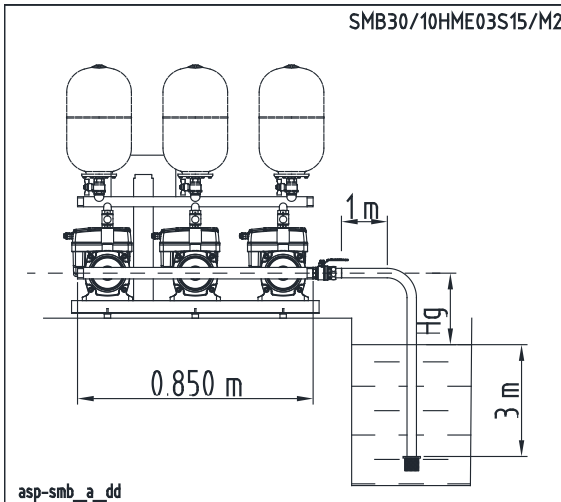

The relation that must be assessed, and which connects this value, is the following:

NPSH available  $\geq$  NPSH required, when the equality condition represents the limit condition.

$$\text{NPSH available} = \text{Patm} + \text{Hg} - \Sigma t - \Sigma a$$

Where:

Patm is the atmospheric pressure, equal to 10,33 m

Hg is the geodetic level difference

$\Sigma t$  are the pressure drops for suction components such as foot check valve, suction piping, curve, gate valve.

$\Sigma a$  are the pressure drops for suction set branch.

NPSH requested is a parameter obtained from the performance curve; in our case, at the flow of each pump equal to 10 m<sup>3</sup>/h, it corresponds to 1,2 m (page 145). Before calculating the NPSH available, it is necessary to calculate the pressure drops at the suction, using the tables on page 163-164, and taking into account the material, such as the type of stainless steel for the piping and cast iron for the valves.

The total sum of the pressure drops  $\Sigma t$  for suction components is made in the following way, considering that the diameter of the suction piping is DN65, equal to the diameter of the suction manifold of the set (page 58/64).

Calculation of suction drops  $\Sigma c$  for cast iron components

Equivalent piping length for DN65 foot check valve = 3 m

Equivalent piping length for DN65 gate valve = 0,2 m

Total equivalent length = 3 + 0,2 = 3,2 m

Pressure drops in the suction piping (cast iron)  $\Sigma c = 3,2 \times 17,6 / 100 = 0,56$  m

Calculation of suction drops  $\Sigma s$  for stainless steel components

Equivalent piping length for DN65 90° curve = 1,3 m

Total equivalent length = 1,3 m

Horizontal suction pipe length = 1 m

Vertical suction pipe length = 3 m

Pressure drops in the suction piping (stainless steel)  $\Sigma s = (1,3 + 1 + 3) \times 17,6 \times 0,54 / 100 = 0,50$  m

Pressure drops for suction components  $\Sigma t = \Sigma c + \Sigma s = 0,56 + 0,50 = 1,06$  m

The total sum of the pressure drops  $\Sigma a$  for suction components is made in the following way, considering that the diameter of the suction piping is DN65, equal to the diameter of the suction manifold of the set (page 58/64).

Hc pressure drops for suction set branch must be assessed on the B curve (page 151, scheme A0536\_A\_CH); at the flow value of each pump equal to 10 m<sup>3</sup>/h, a value of Hc = 0,0035 m is obtained

Calculation of suction drops  $\Sigma s$  for stainless steel components

Equivalent piping length for DN65 manifold T fitting = 2,6 m

Suction manifold length = 0,85 m

Pressure drops in the suction manifold (steel)  $\Sigma s = (2,6 + 0,85) \times 17,6 \times 0,54 / 100 = 0,327$  m

Pressure drops  $\Sigma a = Hc + \Sigma s = 0,0035 + 0,327 = 0,331$  m

Remembering that NPSH available = Patm + Hg -  $\Sigma t$  -  $\Sigma a$  and that NPSH available  $\geq$  NPSH requested we have that Patm + Hg -  $\Sigma t$  -  $\Sigma a$  must be  $\geq$  NPSH requested.

Substituting the values we get that 10,33 + Hg - 1,06 - 0,331  $\geq$  1,2 m (NPSH requested),

Hg = 1,2 + 1,06 + 0,331 - 10,33 = - 7,74 m, it represents the limit condition for which

**NPSH available = NPSH requested**

Therefore, in order to guarantee the conditions for the correct operation of the system as far as cavitation risks, it will be necessary to position the pump above the water level, **so that the Hg height is below the limit value of 7,74 m.**

## SMB BOOSTER SETS SERIES NET PRESSURE CALCULATION

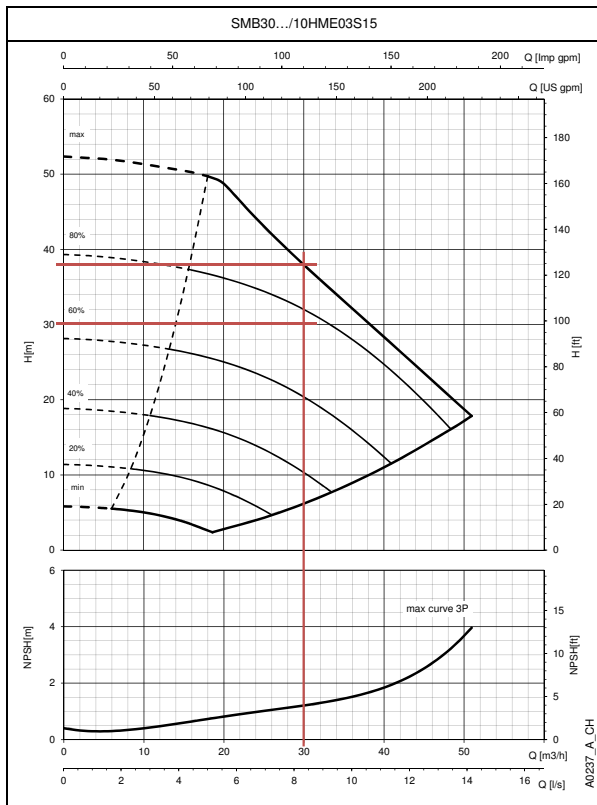

When selecting SMB booster sets, the performance levels of the pump must be taken into account.

Performance levels are obtained from the characteristic curves of the pumps, and do not take into account any pressure drops due to system piping and valves.

The following example helps the customer to obtain the **correct delivery manifold pressure value:**

by knowing the system operating point  $Q = 30 \text{ m}^3/\text{h}$  and  $H = 30 \text{ mH}_2\text{O}$  (P requested), and the installation height  $H_g$  (estimated to 3 m), in order to make the calculations easier we use the pressure drop curves for each single pump on page 145 of this catalogue.

Assuming that a booster set SMB30/10HME03S15 with non-return valves on the delivery has been selected, we proceed as follows:

$P_{\text{net available}} \geq P_{\text{requested}}$ , when the equality condition represents the limit condition.

$$P_{\text{net available}} = H - (H_g + \sum t + \sum a + \sum m)$$

Where:

H head value of booster set

$H_g$  is the geodetic level difference (estimated to 3 m)

$\sum t$  are the pressure drops for suction components such as foot check valve, suction piping, curve and gate valve.

$\sum a$  are the pressure drops for suction set branch

$\sum m$  are the pressure drops for delivery set branch

The total sum of the pressure drops for suction components  $\sum t = \sum c + \sum s = 0,56 + 0,50 = 1,06 \text{ m}$

The total sum of the pressure drops  $\sum t$  for suction components is made in the following way, considering that the diameter of the suction piping is DN65, equal to the diameter of the suction manifold of the set (page 58/64).

$H_c$  pressure drops for suction set branch must be assessed on the B curve (page 151, scheme A0536\_A\_CH); at the flow value of each pump equal to  $10 \text{ m}^3/\text{h}$ , a value of  $H_c = 0,0035 \text{ m}$  is obtained.

Calculation of suction drops  $\sum s$  for stainless steel components

Equivalent piping length for DN65 manifold TEE fitting = 2,6 m

Suction manifold length = 0,85

Pressure drops in the suction piping (stainless steel)  $\sum s = (2,6 + 0,85) \times 17,6 \times 0,54 / 100 = 0,327 \text{ m}$

The total pressure drops  $\sum a$  for suction components are:

$\sum a = H_c + \sum s = 0,0035 + 0,327 = 0,33 \text{ m}$

The total sum of the pressure drops  $\sum m$  for delivery branch is made in the following way, considering that the diameter of the delivery manifold is DN65, equal to the diameter of the delivery manifold of the set (page 58/64).

$H_c$  pressure drops for delivery set branch must be assessed on the A curve (page 151, scheme A0536\_A\_CH); at the flow value of each pump equal to  $10 \text{ m}^3/\text{h}$ , a value of  $H_c = 1,8 \text{ m}$  is obtained

Calculation of delivery drops  $\sum s$  for stainless steel components

Equivalent piping length for DN65 manifold TEE fitting = 2,6 m

Delivery manifold length = 0,85 m

Pressure drops in the delivery manifold (steel)  $\sum s = (2,6 + 0,85) \times 17,6 \times 0,54 / 100 = 0,327 \text{ m}$

Pressure drops in delivery manifold  $\sum m = H_c + \sum s = 1,8 + 0,327 = 2,12 \text{ m}$

If we analyse the performance of the set at the flow value of  $30 \text{ m}^3/\text{h}$ , the head value H is 38 m.

The net pressure at the delivery manifold will be  $P_{\text{net available}} = H - (H_g + \sum t + \sum a + \sum m)$

Substituting the values we get that  $P_{\text{net available}} = 38 - (3 + 1,06 + 0,33 + 2,12) = 31,5$

When comparing this value with the design value (not taking into account the dynamic energy) we see that  $31,5 \text{ m} > 30 \text{ m}$  [ $P_{\text{net available}} > P_{\text{Required}}$ ]

**The set is therefore capable of meeting system requirements.**



# **SMB10, SMB20, SMB30 SERIES**

Variable speed booster sets

e-SV SMART series multistage vertical electric pumps

e-HM SMART series multistage horizontal electric pumps

High efficiency motors with integrated e-SM drive

Flow rate up to 90 m<sup>3</sup>/h and pressure up to 16 bar

## SMB10 BOOSTER SETS SERIES IDENTIFICATION CODE

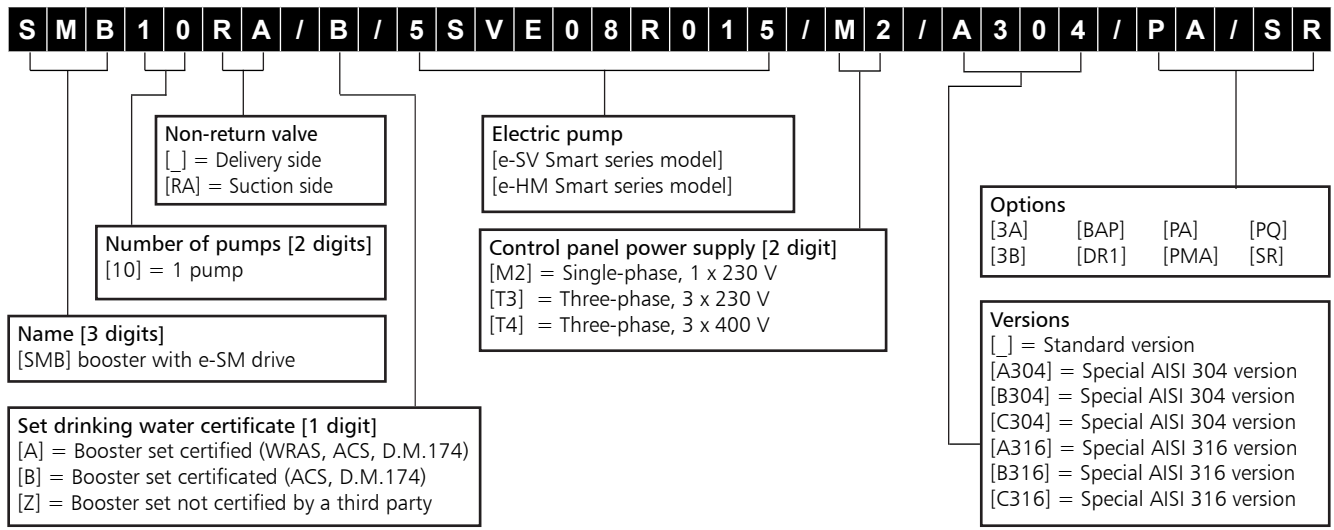

### VERSIONS AVAILABLE

- A304 Main components in contact with the liquid in AISI 304 stainless steel or higher. Galvanised screws and bolts. Flanges not in contact with the liquid galvanised (Available in the Z version).
- B304 Main components in contact with the liquid in AISI 304 stainless steel or higher. Screws and bolts in AISI 304 stainless steel or higher. Flanges not in contact with the liquid in AISI 304 stainless steel (Available in the Z version).
- C304 Main components in contact with the liquid in AISI 304 stainless steel or higher. Base, brackets, supports, screws and bolts in AISI 304 stainless steel or higher. Flanges not in contact with the liquid in AISI 304 stainless steel or higher. Valves fully made of AISI 304 stainless steel or higher (body, heads, disc) (Available in the Z version).
- A316 Main components in contact with the liquid in AISI 316 stainless steel or higher. Galvanised screws and bolts. Flanges not in contact with the liquid galvanised (Available in the Z version). \*
- B316 Main components in contact with the liquid in AISI 316 stainless steel. Screws and bolts in AISI 316 stainless steel. Flanges not in contact with the liquid in AISI 316 stainless steel (Available in the Z version). \*
- C316 Main components in contact with the liquid in AISI 316 stainless steel. Base, brackets, supports, screws and bolts in AISI 316 stainless steel. Flanges not in contact with the liquid in AISI 316 stainless steel. Valves fully made of AISI 316 stainless steel (body, heads, disc) (Available in the Z version). \*

\* Vessel in AISI 304 only.

### OPTIONS

- 3A Set with 1A certified pumps (Factory test report issued from end of line, QH curve included).
- 3B Set with 1B certified pumps (Test bulletin issued by Sala Audit (Audit Room); it includes QH curve, output and power).
- BAP High pressure pressure switch on the delivery side. \*\*
- DR1 Set with 1 optical sensor for lack/presence of water, installed on the suction side.
- PA Minimum pressure pressure switch on the suction side, for protection against dry running. \*\*
- PMA Minimum pressure pressure switch and vacuum pressure gauge for protection against dry running, installed on the suction side. \*\*
- SR Without non-return valve.

\*\* These options are not feasible concurrently in the same unit.

## SMB20, SMB30 BOOSTER SETS SERIES IDENTIFICATION CODE

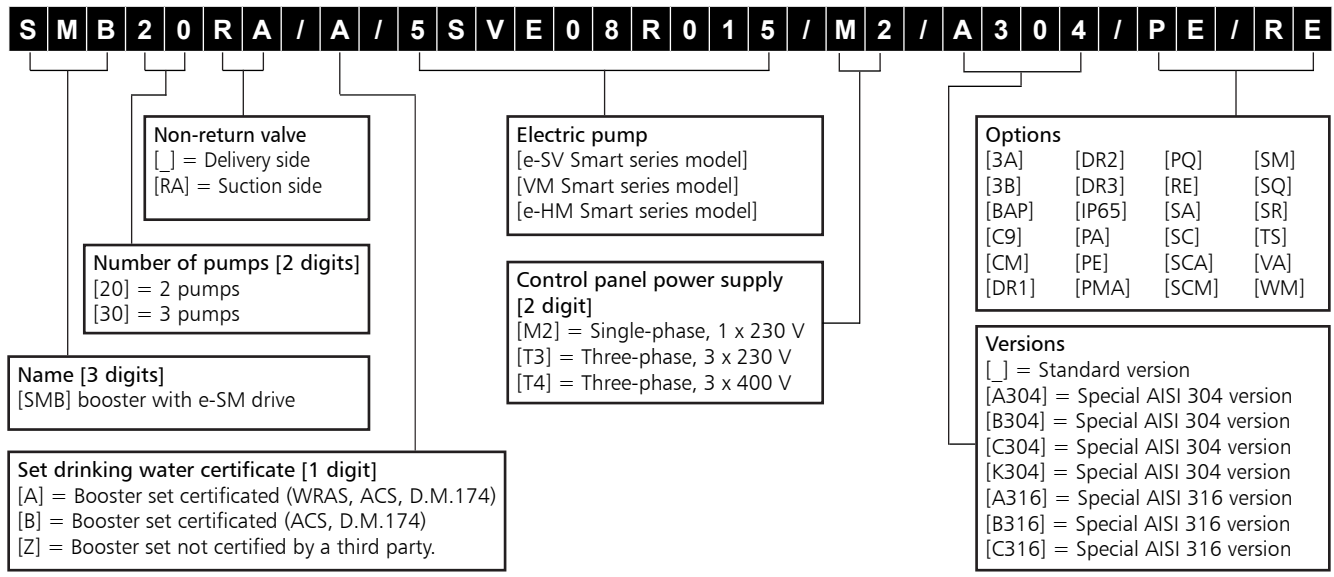

### VERSIONS AVAILABLE

- A304 Main components in contact with the liquid in AISI 304 stainless steel or higher. Galvanised screws and bolts. Flanges not in contact with the liquid galvanised (Available in the Z version).
- B304 Main components in contact with the liquid in AISI 304 stainless steel or higher. Screws and bolts in AISI 304 stainless steel or higher. Flanges not in contact with the liquid in AISI 304 stainless steel (Available in the Z version).
- C304 Main components in contact with the liquid in AISI 304 stainless steel or higher. Base, brackets, supports, screws and bolts in AISI 304 stainless steel or higher. Flanges not in contact with the liquid in AISI 304 stainless steel or higher. Valves fully made of AISI 304 stainless steel or higher (body, heads, disc) (Available in the Z version).
- K304 Baseplate made of AISI 304.
- A316 Main components in contact with the liquid in AISI 316 stainless steel or higher. Galvanised screws and bolts. Flanges not in contact with the liquid galvanised (Available in the Z version).
- B316 Main components in contact with the liquid in AISI 316 stainless steel. Screws and bolts in AISI 316 stainless steel. Flanges not in contact with the liquid in AISI 316 stainless steel (Available in the Z version).
- C316 Main components in contact with the liquid in AISI 316 stainless steel. Base, brackets, supports, screws and bolts in AISI 316 stainless steel. Flanges not in contact with the liquid in AISI 316 stainless steel. Valves fully made of AISI 316 stainless steel (body, heads, disc) (Available in the Z version).

### OPTIONS

- 3A Set with 1A certified pumps (Factory test report issued from end of line, QH curve included).
- 3B Set with 1B certified pumps (Test bulletin issued by Sala Audit (Audit Room); it includes QH curve, output and power).
- BAP High pressure pressure switch on the delivery manifold.
- C9 Delivery manifold turned by 90°, curves. It is not possible to install expansion vessels directly on the manifold.
- CM Suction or delivery manifold larger than standard size.
- DR1 Set with 1 optical sensor for lack/presence of water, installed on the suction manifold.
- DR2 Set with 2 optical sensors for lack/presence of water (fixed to each pump).
- DR3 Set with 3 optical sensors for lack/presence of water (fixed to each pump).
- IP65 IP65 protection degree control panel.
- PA Minimum pressure pressure switch on the suction manifold, for protection against dry running.
- PE Control panel with emergency button.
- PMA Minimum pressure pressure switch and vacuum pressure gauge for protection against dry running, installed on the suction manifold.
- PQ Set for aqueduct installation (with pressure gauge/ pressure switches/transmitters oversized by one size).
- RE Control panel with condensation resistance, controlled by a thermostat.
- SA Without suction: without suction valves and without suction manifold.
- SC Set without control devices such as pressure switches and transmitters; with pressure gauge.
- SCA Without suction manifold (but with suction valves).
- SCM Without delivery manifold (without pressure switches, transmitters and pressure gauge; with delivery valves).
- SM Without delivery: without delivery valves and without delivery manifold.
- SQ Booster set without control panel and bracket; with pressure transmitters and e-SM drive.
- SR Without non-return valve.
- TS Set with electric pumps with special seals.
- VA Control panel with digital voltmeter and ammeter.
- WM Wall mounted control panel; cables L=5m.

## SMB BOOSTER SETS SERIES RANGE

The standard range of SMB series variable-speed booster sets includes models with 1, 2 and 3 electric pumps in different configurations, to adapt to the specific needs of each application.

### Specifications:

- Single-phase and three-phase power supply, variable speed and control by pressure transducers and e-SM frequency converter drives, integrated with permanent magnets motors.

#### SMB10 SERIES

- One electric pump e-SVE, e-HME series.
- **Head** up to 158 m.
- **Flow rate** up to 30 m<sup>3</sup>/h.

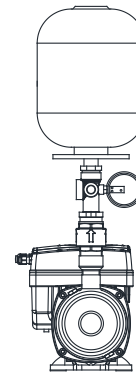

#### SMB20 SERIES

- Two electric pumps e-SVE, e-HME series.
- **Head** up to 158 m.
- **Flow rate** up to 60 m<sup>3</sup>/h.

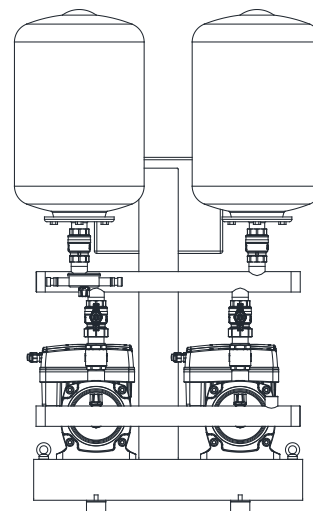

#### SMB30 SERIES

- Three electric pumps e-SVE, e-HME series.
- **Head** up to 158 m.
- **Flow rate** up to 90 m<sup>3</sup>/h.

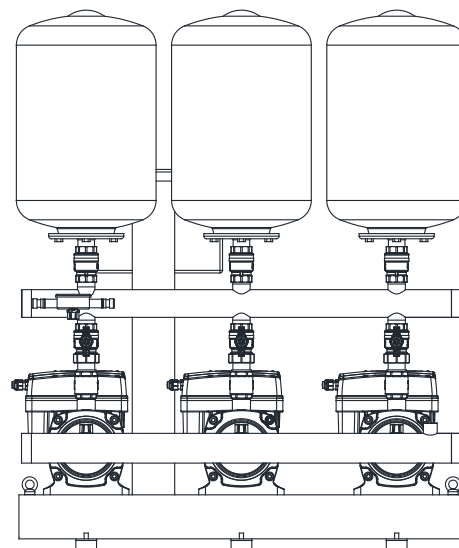

## **e-SM DRIVE**

### **GENERAL DESCRIPTION**

#### **Background and context**

In every sector, from construction and industry to agriculture and building services the need for intelligent, compact and high-efficiency pumping systems is constantly growing.

That's why Lowara has developed the **e-SM drive**: an integrated intelligent pumping system with electronically driven, permanent magnet motor (IE5 efficiency level).

The integrated control system, combined with the high performance, power and efficiency from the motor and hydraulics, guarantees impressively low operating costs. You also benefit from flexibility, precision and its ultra-compact size.

#### **Savings**

The electronics and permanent magnet motor are highly efficient and minimize power losses while transferring maximum energy to the hydraulic parts of the pump.

The refined control system with integrated microprocessor adjusts the motor speed, matching the required operating point of the pump or system requirements.

This reduces demand on electricity according to the required working conditions.

This creates economies, especially in systems where pump demand varies over time.

#### **Flexibility**

The compact size, low loss and increased control make the e-SM drive a good choice in applications and systems where fixed speed pumps are commonly used. It is easy to integrate in control and regulation loops thanks to the wide availability of compatible communication protocols, including analog and digital inputs.

The pump is supplied with a pressure sensor.

#### **Ease of use and commissioning**

e-SM drive has an intuitive interface that guides the user through the installation, and an easily accessible area for connections.

The control system is integrated and no additional external electrical panel is required.

#### **Application sectors**

- Water supply systems in residential buildings
- Air conditioning
- Water treatment plants
- Industrial installations

#### **e-SM System**

- Single-phase power supply: 220-240V, 50/60 Hz
- Three-phase power supply:
  - from 0,37kW to 1,5kW: 220-240V/380-415V 50/60 Hz
  - 2,2kW: 400V +/- 10%, 50/60 Hz
- Power up to 1,5kW for single-phase version
- Power up to 2,2kW for three-phase version
- Protection class IP55
- Can be linked up to 3 pumps

#### **Motor**

- IE5 efficiency level (IEC TS 60034-30-2:2016)
- Synchronous electric motor with permanent magnets, (TEFC), closed structure, air-cooled
- Insulation class 155 (F)
- Overload protection and locked rotor with automatic reset incorporated

#### **Optional components:**

##### **Sensors**

The following sensors are available for electric pump equipped with e-SM drive:

- Pressure-transducer
- Level-sensor.

## PUMPS WITH e-SM DRIVE GENERAL DESCRIPTION

### e-SV Smart (e-SVE)

#### Pump

- **Flow rate:** up to 30 m<sup>3</sup>/h
- **Head:** up to 136 m
- Ambient temperature: from -20°C to +50°C without performance penalty
- Temperature of pumped liquid up to +120°C
- Maximum operating **pressure:**
  - 1, 3, 5, 10, 15, 22SV with oval flanges: 16 bar (PN16) at 50°C.
  - 1, 3, 5, 10, 15, 22SV with round flanges or Victaulic®, Clamp, o DIN 11851 connections: 25 bar (PN 25) a 50°C.
- Vertical multistage centrifugal pump. All metal parts in contact with the pumped liquid are made of stainless steel.
- **F:** round flanges, in-line delivery and suction ports, AISI 304.
- **R:** round flanges, delivery port above the suction port, with four adjustable positions, AISI 304.
- Further choice possibilities among the following versions:
  - **T:** oval flanges, in-line delivery and suction ports, AISI 304.
  - **N:** round flanges, in-line delivery and suction ports, AISI 316.
- Reduced axial thrusts enable the use of **standard motors** that are easily found in the market.
- Mechanical seal according to EN 12756 (ex DIN 24960) and ISO 3069 for 1, 3, 5SV and 10, 15, 22SV (≤ of 4 kW) series.
- **Balanced mechanical seal** according to EN 12756 (ex DIN 24960) and ISO 3069, which **can be replaced without removing the motor from the pump** for 10, 15 and 22SV (≥ of 5,5 kW) series.
- Seal housing chamber designed to prevent the accumulation of air in the critical area next to the mechanical seal.
- A second plug is available for 10, 15, 22SV series.
- Easy maintenance. No special tools required for assembly or disassembly.
- The hydraulic performances meet the tolerances specified in ISO 9906:2012.



### VM Smart (VME)

#### Pump

- **Flow rate:** up to 17 m<sup>3</sup>/h
- **Head:** up to 100 m
- Ambient temperature: from -20°C to +50°C without performance penalty
- Temperature of pumped liquid up to +90°C
- Maximum operating **pressure:** 10 bar (PN 10)
- Connections: Rp threaded for both suction and discharge manifold
- The hydraulic performances meet the tolerances specified in ISO 9906:2012.



### e-HM Smart (e-HME)

#### Pump

- **Flow rate:** up to 29 m<sup>3</sup>/h
- **Head:** up to 158 m
- Ambient temperature: from -20°C to +50°C without performance penalty
- Temperature of pumped liquid up to +120°C
- Maximum operating **pressure:** 16 bar (PN 16)
- Connections: Rp threaded for both suction and discharge manifold
- The hydraulic performances meet the tolerances specified in ISO 9906:2012.



## e-SM DRIVE SERIES

**Integrated intelligence:** The electronic control of the motor enables a 20% increase in performance compared to an equivalent fixed speed pump (area highlighted in figure "Integrated intelligence").

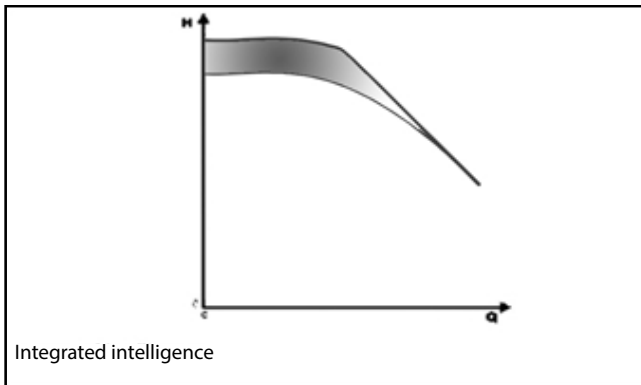

**Adjustment:** This is possible both at constant pressure and according to the characteristic curve of the system, based on the customer's preferences. Another option is according to an external signal or at a preset speed.

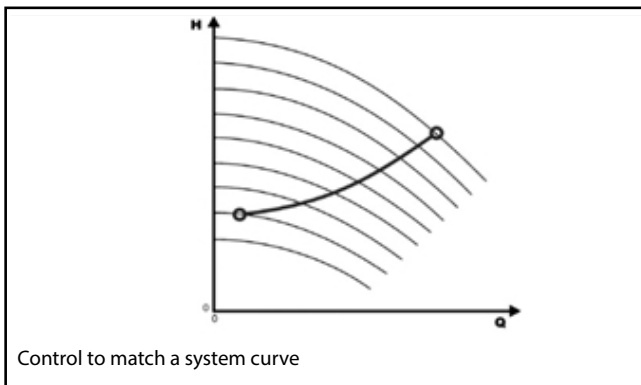
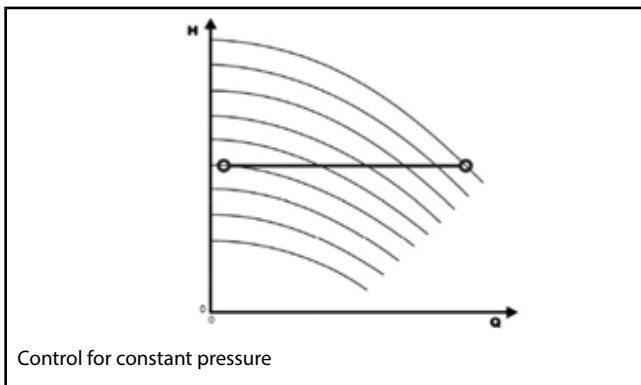

**Intuitive and simple interface:** You can control the unit from just three buttons, with an easy to read display for parameters and alarms, designed for complete control of system operation.

- ① Communication LED
- ② Power on LED
- ③ Unit of measure LED
- ④ Speed LED bar
- ⑤ Status LED
- ⑥ Numeric display
- ⑦  $\ominus$  decrease key
- ⑧  $\text{⏻}$  on/off and menu key
- ⑨  $\oplus$  increase key

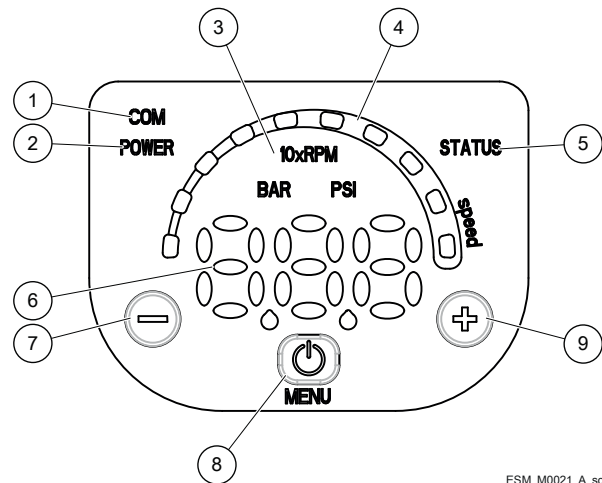

## e-SM DRIVE SERIES SINGLE-PHASE TERMINAL BOX

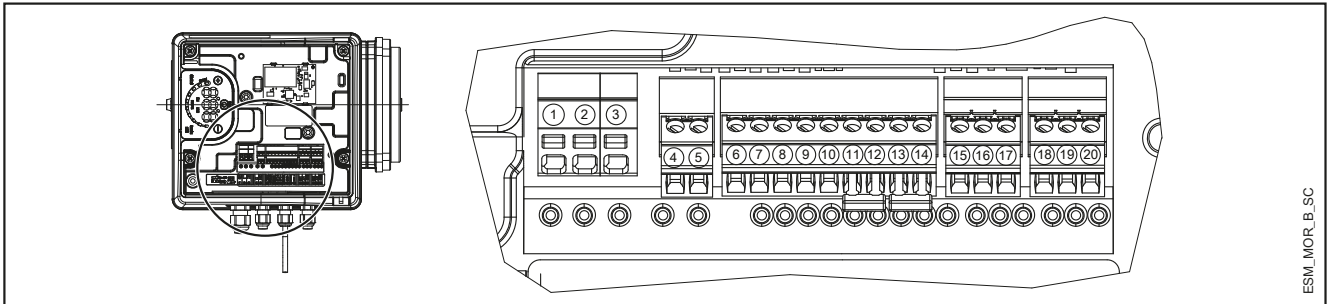

ESM\_MOR\_B\_SC

REF.	ITEM	DESCRIPTION
4	Fault Signal	COM - error status relay
5		NO - error status relay
6	Auxiliary Voltage Supply	Auxiliary voltage supply +15 VDC
7	Analog input 0-10V	Actuator mode 0-10 V input
8		GND for 0-10 V input
9	External Pressure sensor [also Differential]	Power supply external sensor +15 VDC
10		External sensor 4-20 mA input
11	External Start/Stop	External ON/OFF input reference
12		External ON/OFF input
13	External Lack of Water	Low water input
14		Low water reference
15	Communication bus	RS485 port 1: RS485-1N B (-)
16		RS485 port 1: RS485-1P A (+)
17		Electronic GND
18	Communication bus	RS485 port 2: RS485 port 2: RS485-2N B (-) active only with optional module
19		RS485 port 2: RS485 port 2: RS485-2P A (+) active only with optional module
20		Electronic GND

MorsM-en\_a\_sc

## THREE-PHASE TERMINAL BOX

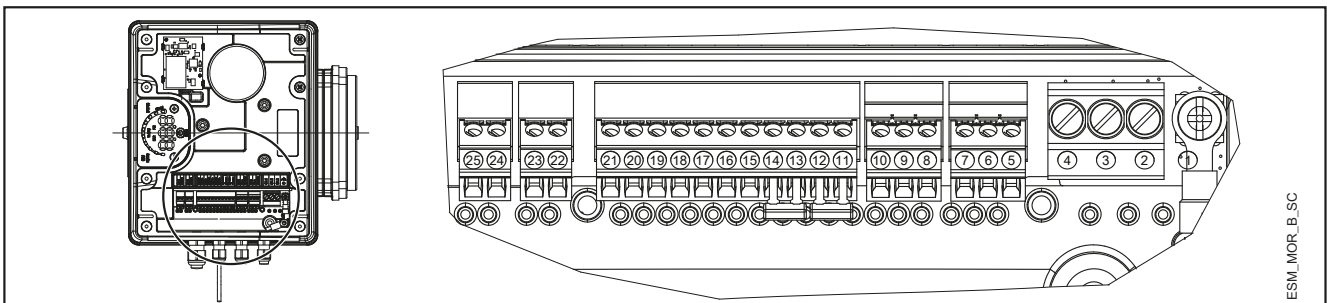

ESM\_MOR\_B\_SC

REF.	ITEM	DESCRIPTION
5		Electronic GND
6	Communication bus	RS485 port 1: RS485-1P A (+)
7		RS485 port 1: RS485-1N B (-)
8		Electronic GND
9	Communication bus	RS485 port 2: RS485 port 2: RS485-2P A (+) active only with optional module
10		RS485 port 2: RS485 port 2: RS485-2N B (-) active only with optional module
11	External Lack of Water	Low water reference
12		Low water input
13	External Start/Stop	External ON/OFF input reference
14		External ON/OFF input
15	External Pressure sensor	External sensor 4-20 mA input
16		Power supply external sensor +15 VDC
17	External Pressure sensor [also Differential]	External sensor 4-20 mA input
18		Power supply external sensor +15 VDC
19	Analog input 0-10V	GND for 0-10 V input
20		Actuator mode 0-10 V input
21	Auxiliary Voltage Supply	Auxiliary voltage supply +15 VDC
22	Motor running signal	Normally open contact
23		Common contact
24	Fault Signal	NO - error status relay
25		COM - error status relay

MorsT-en\_a\_sc

## **SMB20, SMB30 BOOSTER SETS SERIES CONTROL PANEL**

Control and protection panel for electric pumps with integrated frequency converters:

- power supply **single-phase 1x230 V** +/-10%, 50/60Hz (SMB.../M2)
- power supply **three-phase 3x400 V** +/-10%, 50/60Hz (SMB.../T4)
- power supply **three-phase 3x230 V** +/-10%, 50/60Hz (SMB.../T3)

**IP55** protection.

Metal for sets with two and three pumps.  
The IP65 degree is optional (SMB.../IP65)

Main characteristics:

- Automatic switch with thermal magnetic protection for each e-SM drive frequency converter.
- Protection against dry running.  
Protection against dry running activates when the water reserve falls below the minimum level guaranteed for suction. The level can be checked using a float switch, a minimum pressure switch, an external contact, or level probes. For the latter, the probes must be connected to the adjustable sensitivity electronic module. The control panel is already preset for the installation of this module.
- Free contact for fault diagnostic status, for each frequency converter. Electrical contact normally open.

For booster sets requiring a wall mounted control panel (SMB.../WM), the panel is supplied with 5 metre cables.

Other options available:

- SMB.../PA
- SMB.../PE
- SMB.../RE
- SMB.../VA

See the option description on page [17](#).

In SMB10 booster set series, control panel is available as accessory.



Control panel for two and three electric pumps:  
- QESM20 series  
- QESM30 series

## SMB10 BOOSTER SETS SERIES MAIN COMPONENTS

- **Non return valve** on the delivery of each electric pump, spring type.
- **Delivery pipe** with threaded ends.
- **Pressure gauge and transmitters** for control, installed on the delivery side of the set.
- **Pressure tank** 8lt or 24lt depending on the electric pump model.
- **Support base** for SMB10../SVE

### Optional components:

#### Sensors

The following sensors are available for electric pump equipped with e-SM drive:

- Pressure-transducer
- Level-sensor.

## SMB20, SMB30 BOOSTER SETS SERIES MAIN COMPONENTS

- **Main on-off valves** at the suction and delivery of each electric pump, ball type.
- **Non return valve** on the delivery of each electric pump, spring type.
- **Suction manifold** with threaded ends. Threaded fitting for filling the booster set.
- **Delivery manifold** with threaded ends and connections for pressure sensors, pressure gauge and expansion vessels. Expansion vessels are available on request.
- **Pressure gauge and transmitters** for control, installed on the delivery manifold of the set.
- **Control panel.**
- **Various fittings** for the connections.
- **Support base** for the pump set and control panel bracket.

### Optional components:

#### Sensors

The following sensors are available for electric pump equipped with e-SM drive:

- Pressure-transducer
- Level-sensor.

### Versions available

Valves and main components made of AISI 304 or AISI 316 stainless steel;

versions:

SMB../A304, SMB../B304, SMB../C304,  
SMB../A316, SMB../B316, SMB../C316

Available in the Z version.

### Accessories on request:

- Devices **for protection against dry running** in one of the following versions:
  - float switch
  - level probes (electodes) kit
  - minimum pressure switch
- **Vibration dampers**
- **Control panel**

### Versions available

Manifolds, valves, flanges, base and main components made of AISI 304 or AISI 316 stainless steel;

versions:

SMB../A304, SMB../B304, SMB../C304,  
SMB../A316, SMB../B316, SMB../C316

Available in the Z version.

### Accessories on request:

- Devices **for protection against dry running** in one of the following versions:
  - float switch
  - level probes (electodes) kit
  - minimum pressure switch
- **Diaphragm expansion vessel kit**  
Hydrotube with on-off valve, depending on the maximum head of the pump:
  - 24 lt, 8 bar hydro tube kit
  - 24 lt, 10 bar hydro tube kit
  - 24 lt, 16 bar hydro tube kit
  - 20 lt, 25 bar hydro tube kit
- **Vibration dampers** sized depending on the set. In some sets, vibration dampers are provided not assembled; installation is care of the customer.

### SPECIAL EQUIPMENT ON REQUEST (Contact the Sales and Technical Assistance Service)

- Sets with special valves.
- Sets with stainless steel expansion vessels.

For more information about available accessories, please refer to standard catalog.

## SMB10 BOOSTER SETS SERIES MATERIAL TABLE

DENOMINATION	SMB10.. (STANDARD)	SMB10../A304	SMB10../A316
Manifolds	AISI 304	AISI 304	AISI 316
On-off valves	Nickel-plated brass	AISI 316	AISI 316
Non-return valves	Brass	AISI 304	AISI 316
Pressure switches	Galvanized steel/AISI 301	AISI 301	AISI 301
Pressure transmitters	AISI 304	AISI 304	AISI 304
Caps/plugs	AISI 304 / 316	AISI 304 / 316	AISI 316
Sliding/Blind Flanges (not in contact with liquid)	Galvanized steel	Galvanized steel *	Galvanized steel *
Welded flanges (contact with liquid)	AISI 304	AISI 304	AISI 316
Fittings	AISI 316	AISI 316	AISI 316
Base**	Painted steel	Painted steel	Painted steel

\* B304, C304 version in AISI 304; B316, C316 version in AISI 316

g\_smb10\_wad-en\_b\_tm

\*\* Installed in SMB10..SVE booster serie

The SMB10 booster set series with e-SV Smart are equipped with counterflange made of AISI 304 on suction side.

## SMB20, SMB30 BOOSTER SETS SERIES MATERIAL TABLE

DENOMINATION	SMB... (STANDARD)	SMB.../A304	SMB.../A316
Manifolds	AISI 304	AISI 304	AISI 316
On-off valves	Nickel-plated brass	AISI 316	AISI 316
Non-return valves	Brass	AISI 304	AISI 316
Pressure switches	Galvanized steel/AISI 301	AISI 301	AISI 301
Pressure transmitters	AISI 304	AISI 304	AISI 304
Caps/plugs	AISI 304 / 316	AISI 304 / 316	AISI 316
Sliding/Blind Flanges (not in contact with liquid)	Galvanized steel	Galvanized steel *	Galvanized steel *
Welded flanges (contact with liquid)	AISI 304	AISI 304	AISI 316
Fittings	AISI 316	AISI 316	AISI 316
Bracket	Galvanized steel/painted steel	Galvanized steel/painted steel	Galvanized steel/painted steel
Base	Painted steel	Painted steel	Painted steel

\* B304, C304 version in AISI 304; B316, C316 version in AISI 316

g\_smb\_wad-en\_b\_tm

## SMB BOOSTER SETS SERIES WORKING LIMITS

The input pressure of the pump, added to the pressure with the port shut off, must not exceed the maximum permitted operating pressure (PN) of the set.

Permitted liquids	Water without gases and corrosive and/or aggressive substances.
Fluid temperature	-10°C to + 80 °C
Ambient temperature**	0°C to + 40 °C
Maximum operating pressure*	Max 16 bar
Minimum input pressure	In line with the NPSH curve and the losses, with a margin of at least 0,5 m
Maximum input pressure	The input pressure added to the pump pressure without flow must be lower than the maximum operating pressure of the set.
Installation	Internal environment protected from atmospheric agents. Away from heat sources. Max altitude 1000 a.s.l. Max humidity 50%, without condensation.
Sound emission	See table

\* Higher PN available on request depending on pump type

smb\_2p-en\_a\_ti

\*\* SMB10 without control panel, max. 50°C

## SOUND EMISSION LEVELS

3600 min <sup>-1</sup>			LpA (dB ±2)**	
P2 (kW)	IEC*(HME, VME)	IEC* (SVE)	SMB20	SMB30
0,37	80	90R	< 70	< 70
0,55	80	90R	< 70	< 70
0,75	80	90R	< 70	< 70
1,1	80	90R	< 70	< 70
1,5	80	90R	< 70	< 70
2,2	90	90R	< 70	< 70

\* R=Reduced motor casing size with respect to shaft extension and related flange.

SMB\_2p-en\_b\_tr

\*\* Noise value of the electric motor only.

## SMB10/..SVE BOOSTER SETS SERIES SINGLE-PHASE TABLE OF HYDRAULIC PERFORMANCE

** PUMP TYPE SVE Single-phase	MOTOR		e-SM SET		Q = DELIVERY							
	P <sub>N</sub> kW	TYPE 1x230 V	* P <sub>1</sub> kW	* I 208-240 V A	l/min 0	6,7	13,3	20,0	26,7	33,3	40,0	46,7
					m <sup>3</sup> /h 0	0,4	0,8	1,2	1,6	2,0	2,4	2,8
H = TOTAL HEAD IN METRES OF COLUMN OF WATER												
1SVE05..003	0,37	ESM90R/103 SVE	1 x 0,49	2,24	44,7	45,0	45,2	44,6	41,5	35,0	28,1	20,8
1SVE08..005	0,55	ESM90R/105 SVE	1 x 0,68	3,07	71,5	72,0	72,3	71,2	62,3	52,0	41,2	29,6
1SVE11..007	0,75	ESM90R/107 SVE	1 x 0,91	4,04	98,3	99,1	99,3	97,7	85,1	70,9	56,0	40,0
1SVE15..011	1,1	ESM90R/111 SVE	1 x 1,33	5,85	134,1	135,1	135,5	133,8	123,6	103,9	83,3	61,4

** PUMP TYPE SVE Single-phase	MOTOR		e-SM SET		Q = DELIVERY							
	P <sub>N</sub> kW	TYPE 1x230 V	* P <sub>1</sub> kW	* I 208-240 V A	l/min 0	13,3	26,7	40,0	53,3	66,7	80,0	86,7
					m <sup>3</sup> /h 0	0,8	1,6	2,4	3,2	4,0	4,8	5,2
H = TOTAL HEAD IN METRES OF COLUMN OF WATER												
3SVE03..003	0,37	ESM90R/103 SVE	1 x 0,49	2,24	33,4	33,7	33,6	30,7	24,9	19,5	14,0	10,9
3SVE05..005	0,55	ESM90R/105 SVE	1 x 0,69	3,08	55,7	56,2	55,8	46,3	37,1	28,4	19,5	14,4
3SVE07..007	0,75	ESM90R/107 SVE	1 x 0,92	4,06	77,9	78,7	77,2	63,4	50,7	38,6	26,0	18,7
3SVE09..011	1,1	ESM90R/111 SVE	1 x 1,33	5,85	100,2	101,0	100,5	88,8	72,5	56,4	39,9	31,2
3SVE11..015	1,5	ESM90R/115 SVE	1 x 1,78	7,80	122,5	123,3	122,5	117,9	98,4	78,0	57,2	46,3

** PUMP TYPE SVE Single-phase	MOTOR		e-SM SET		Q = DELIVERY							
	P <sub>N</sub> kW	TYPE 1x230 V	* P <sub>1</sub> kW	* I 208-240 V A	l/min 0	23,3	46,7	70,0	93,3	116,7	140,0	166,7
					m <sup>3</sup> /h 0	1,4	2,8	4,2	5,6	7,0	8,4	10,0
H = TOTAL HEAD IN METRES OF COLUMN OF WATER												
5SVE02..003	0,37	ESM90R/103 SVE	1 x 0,49	2,24	22,4	22,2	21,8	20,0	16,5	13,3	10,2	6,5
5SVE03..005	0,55	ESM90R/105 SVE	1 x 0,68	3,07	33,5	33,3	32,7	29,8	24,5	19,8	15,2	9,5
5SVE04..007	0,75	ESM90R/107 SVE	1 x 0,91	4,05	44,7	44,4	43,5	40,5	33,4	27,1	20,8	13,3
5SVE06..011	1,1	ESM90R/111 SVE	1 x 1,33	5,86	67,1	66,6	65,3	59,5	49,0	39,6	30,4	19,1
5SVE08..015	1,5	ESM90R/115 SVE	1 x 1,78	7,81	88,8	89,3	87,6	82,6	68,3	55,3	42,6	27,9

** PUMP TYPE SVE Single-phase	MOTOR		e-SM SET		Q = DELIVERY							
	P <sub>N</sub> kW	TYPE 1x230 V	* P <sub>1</sub> kW	* I 208-240 V A	l/min 0	40,0	80,0	120,0	160,0	200,0	240,0	283,3
					m <sup>3</sup> /h 0	2,4	4,8	7,2	9,6	12,0	14,4	17,0
H = TOTAL HEAD IN METRES OF COLUMN OF WATER												
10SVE01..005	0,55	ESM90R/105 SVE	1 x 0,68	3,07	17,3	17,3	16,9	16,2	13,6	10,4	7,1	3,3
10SVE02..007	0,75	ESM90R/107 SVE	1 x 0,92	4,09	24,2	23,9	23,1	21,7	19,3	14,6	9,7	3,6
10SVE02..011	1,1	ESM90R/111 SVE	1 x 1,33	5,85	34,8	34,5	33,7	32,3	27,7	22,4	17,1	11,0
10SVE03..015	1,5	ESM90R/115 SVE	1 x 1,78	7,81	52,7	52,2	51,0	46,1	38,1	30,8	23,5	15,1

** PUMP TYPE SVE Single-phase	MOTOR		e-SM SET		Q = DELIVERY							
	P <sub>N</sub> kW	TYPE 1x230 V	* P <sub>1</sub> kW	* I 208-240 V A	l/min 0	70,0	140,0	210,0	280,0	350,0	420,0	483,3
					m <sup>3</sup> /h 0	4,2	8,4	12,6	16,8	21,0	25,2	29,0
H = TOTAL HEAD IN METRES OF COLUMN OF WATER												
15SVE01..007	0,75	ESM90R/107 SVE	1 x 0,92	4,10	14,2	13,9	13,3	12,3	9,8	6,4	2,8	
15SVE01..011	1,1	ESM90R/111 SVE	1 x 1,33	5,85	20,5	20,1	19,4	18,4	14,8	10,9	7,0	3,2
15SVE02..015	1,5	ESM90R/115 SVE	1 x 1,76	7,71	29,6	29,1	28,3	26,8	22,2	16,4	10,1	3,8

** PUMP TYPE SVE Single-phase	MOTOR		e-SM SET		Q = DELIVERY							
	P <sub>N</sub> kW	TYPE 1x230 V	* P <sub>1</sub> kW	* I 208-240 V A	l/min 0	70,0	140,0	210,0	280,0	350,0	420,0	500,0
					m <sup>3</sup> /h 0	4,2	8,4	12,6	16,8	21,0	25,2	30,0
H = TOTAL HEAD IN METRES OF COLUMN OF WATER												
22SVE01..007	0,75	ESM90R/107 SVE	1 x 0,89	3,95	14,4	14,4	14,1	12,5	9,5	6,3	2,9	
22SVE01..011	1,1	ESM90R/111 SVE	1 x 1,34	5,87	20,7	20,8	20,5	18,7	15,1	11,5	7,8	3,2
22SVE02..015	1,5	ESM90R/115 SVE	1 x 1,72	7,56	31,4	31,0	30,3	26,7	21,7	16,7	11,0	2,8

Table refers to hydraulic performances with one pump running, max rpm, friction loss not included

g10\_1-22sve-esm-2p50-en\_a\_th

\* Maximum value in specified range: P<sub>1</sub> = input power; I = input nominal current absorbed by set

\*\* For technical details see see technical catalogue of single electric pump

## SMB10/..VME BOOSTER SETS SERIES SINGLE-PHASE TABLE OF HYDRAULIC PERFORMANCE

** PUMP TYPE VME Single-phase	MOTOR		e-SM SET		Q = DELIVERY							
	P <sub>N</sub> kW	TYPE 1x230 V	* P <sub>1</sub> kW	* I 208-240 V A	l/min 0	6,7	13,3	20,0	26,7	33,3	40,0	50,0
					m <sup>3</sup> /h 0	0,4	0,8	1,2	1,6	2,0	2,4	3,0
H = TOTAL HEAD IN METRES OF COLUMN OF WATER												
1VME02P03	0,37	ESM80/103 HM..	1 x 0,49	2,24	34,4	33,3	32,1	30,6	28,3	24,4	20,4	14,6
1VME04P05	0,55	ESM80/105 HM..	1 x 0,69	3,07	57,5	55,3	53,1	50,4	46,7	39,3	32,0	21,9
1VME05P07	0,75	ESM80/107 HM..	1 x 0,91	4,04	80,8	78,0	75,0	71,7	63,0	53,5	44,1	30,8
1VME06P11	1,1	ESM80/111 HM..	1 x 1,33	5,85	99,8	96,3	92,8	88,5	83,2	76,1	65,5	47,9

** PUMP TYPE VME Single-phase	MOTOR		e-SM SET		Q = DELIVERY							
	P <sub>N</sub> kW	TYPE 1x230 V	* P <sub>1</sub> kW	* I 208-240 V A	l/min 0	13,3	26,7	40,0	53,3	66,7	80,0	86,7
					m <sup>3</sup> /h 0	0,8	1,6	2,4	3,2	4,0	4,8	5,2
H = TOTAL HEAD IN METRES OF COLUMN OF WATER												
3VME02P03	0,37	ESM80/103 HM..	1 x 0,49	2,24	35,5	34,3	31,2	25,0	19,5	14,5	9,8	7,5
3VME03P05	0,55	ESM80/105 HM..	1 x 0,69	3,07	53,2	51,3	47,1	37,9	29,8	22,7	16,1	12,4
3VME04P07	0,75	ESM80/107 HM..	1 x 0,91	4,06	70,9	68,3	63,9	51,6	40,6	31,1	22,3	17,3
3VME05P11	1,1	ESM80/111 HM..	1 x 1,33	5,85	88,6	85,5	82,4	74,3	59,5	46,6	34,8	28,8
3VME06P15	1,5	ESM80/115 HM..	1 x 1,78	7,78	100,5	96,8	93,2	86,6	77,0	64,1	49,3	42,0

** PUMP TYPE VME Single-phase	MOTOR		e-SM SET		Q = DELIVERY							
	P <sub>N</sub> kW	TYPE 1x230 V	* P <sub>1</sub> kW	* I 208-240 V A	l/min 0	20,0	40,0	60,0	80,0	100,0	120,0	140,0
					m <sup>3</sup> /h 0	1,2	2,4	3,6	4,8	6,0	7,2	8,4
H = TOTAL HEAD IN METRES OF COLUMN OF WATER												
5VME02P05	0,55	ESM80/105 HM..	1 x 0,69	3,07	36,3	34,8	33,4	29,1	23,4	18,7	14,1	8,9
5VME03P07	0,75	ESM80/107 HM..	1 x 0,92	4,06	54,2	52,4	49,8	39,9	32,5	25,8	18,8	11,5
5VME04P11	1,1	ESM80/111 HM..	1 x 1,33	5,85	72,3	69,9	66,3	57,8	47,4	38,2	28,6	18,6
5VME05P15	1,5	ESM80/115 HM..	1 x 1,78	7,80	90,4	87,4	82,9	77,9	64,2	52,3	40,1	27,3

** PUMP TYPE VME Single-phase	MOTOR		e-SM SET		Q = DELIVERY							
	P <sub>N</sub> kW	TYPE 1x230 V	* P <sub>1</sub> kW	* I 208-240 V A	l/min 0	40,0	80,0	120,0	160,0	200,0	240,0	283,3
					m <sup>3</sup> /h 0	2,4	4,8	7,2	9,6	12,0	14,4	17,0
H = TOTAL HEAD IN METRES OF COLUMN OF WATER												
10VME01P07	0,75	ESM80/107 HM..	1 x 0,91	4,04	22,6	22,2	21,2	20,0	16,6	13,5	10,4	6,8
10VME02P11	1,1	ESM80/111 HM..	1 x 1,34	5,86	38,0	37,2	35,4	30,7	24,7	19,2	13,4	6,7

Table refers to hydraulic performances with one pump running, max rpm, friction loss not included

g10\_1-10vme-esm-2p50-en\_a\_th

\* Maximum value in specified range: P<sub>1</sub> = input power; I = input nominal current absorbed by set

\*\* For technical details see technical catalogue of single electric pump

## SMB10/..HME BOOSTER SETS SERIES SINGLE-PHASE TABLE OF HYDRAULIC PERFORMANCE

** PUMP TYPE HME..S, HME..N Single-phase	MOTOR P <sub>N</sub> kW TYPE 1x230 V		e-SM SET * P <sub>1</sub> kW * I 208-240 V A		Q = DELIVERY							
					l/min 0	6,7	13,3	20,0	26,7	33,3	40,0	46,7
					m <sup>3</sup> /h 0	0,4	0,8	1,2	1,6	2,0	2,4	2,8
H = TOTAL HEAD IN METRES OF COLUMN OF WATER												
1HME05S03	0,37	ESM80/103 HM..	1 x 0,49	2,24	44,7	44,8	44,9	44,1	39,2	32,5	25,7	18,9
1HME08S05	0,55	ESM80/105 HM..	1 x 0,69	3,07	71,6	71,5	71,7	70,4	60,3	50,0	39,6	29,0
1HME11S07	0,75	ESM80/107 HM..	1 x 0,91	4,04	98,5	98,5	98,8	94,3	80,7	66,8	52,9	38,6
1HME15S11	1,1	ESM80/111 HM..	1 x 1,33	5,85	134,0	134,4	134,6	132,3	119,5	99,5	79,6	59,6
1HME17S15	1,5	ESM80/115 HM..	1 x 1,77	7,77	151,8	152,2	152,7	149,6	141,6	128,6	110,7	87,2

** PUMP TYPE HME..S, HME..N Single-phase	MOTOR P <sub>N</sub> kW TYPE 1x230 V		e-SM SET * P <sub>1</sub> kW * I 208-240 V A		Q = DELIVERY							
					l/min 0	13,3	26,7	40,0	53,3	66,7	80,0	86,7
					m <sup>3</sup> /h 0	0,8	1,6	2,4	3,2	4,0	4,8	5,2
H = TOTAL HEAD IN METRES OF COLUMN OF WATER												
3HME03S03	0,37	ESM80/103 HM..	1 x 0,49	2,24	33,3	33,9	33,4	31,5	25,6	20,1	14,6	11,8
3HME05S05	0,55	ESM80/105 HM..	1 x 0,69	3,07	55,5	56,5	55,7	47,5	38,2	29,4	20,5	16,0
3HME07S07	0,75	ESM80/107 HM..	1 x 0,91	4,06	77,6	79,1	78,1	64,9	52,0	39,8	27,5	21,3
3HME09S11	1,1	ESM80/111 HM..	1 x 1,33	5,85	99,8	101,8	100,3	93,6	76,1	59,6	43,0	34,7
3HME12S15	1,5	ESM80/115 HM..	1 x 1,78	7,80	133,1	135,9	133,6	127,3	103,6	81,5	59,2	48,1

** PUMP TYPE HME..S, HME..N Single-phase	MOTOR P <sub>N</sub> kW TYPE 1x230 V		e-SM SET * P <sub>1</sub> kW * I 208-240 V A		Q = DELIVERY							
					l/min 0	23,3	46,7	70,0	93,3	116,7	140,0	170,0
					m <sup>3</sup> /h 0	1,4	2,8	4,2	5,6	7,0	8,4	10,2
H = TOTAL HEAD IN METRES OF COLUMN OF WATER												
5HME02S03	0,37	ESM80/103 HM..	1 x 0,49	2,24	22,2	22,4	21,9	19,8	16,2	13,0	9,9	6,0
5HME03S05	0,55	ESM80/105 HM..	1 x 0,69	3,07	33,3	33,6	32,9	29,5	24,1	19,3	14,7	8,8
5HME04S07	0,75	ESM80/107 HM..	1 x 0,91	4,05	44,4	44,7	43,8	40,1	32,8	26,4	20,2	12,2
5HME06S11	1,1	ESM80/111 HM..	1 x 1,33	5,85	66,7	67,2	65,8	59,0	48,1	38,7	29,5	17,5
5HME08S15	1,5	ESM80/115 HM..	1 x 1,78	7,82	88,9	89,5	87,7	80,2	65,5	52,8	40,4	24,4

** PUMP TYPE HME..S, HME..N Single-phase	MOTOR P <sub>N</sub> kW TYPE 1x230 V		e-SM SET * P <sub>1</sub> kW * I 208-240 V A		Q = DELIVERY							
					l/min 0	40,0	80,0	120,0	160,0	200,0	240,0	283,3
					m <sup>3</sup> /h 0	2,4	4,8	7,2	9,6	12,0	14,4	17,0
H = TOTAL HEAD IN METRES OF COLUMN OF WATER												
10HME01S07	0,75	ESM80/107 HM..	1 x 0,86	3,80	17,5	17,5	17,0	16,1	14,7	12,7	10,2	6,6
10HME02S11	1,1	ESM80/111 HM..	1 x 1,33	5,85	34,8	34,9	33,8	32,3	27,2	21,9	16,6	11,1
10HME03S15	1,5	ESM80/115 HM..	1 x 1,78	7,81	52,4	51,8	50,6	46,9	39,2	32,2	25,3	17,8

** PUMP TYPE HME..S, HME..N Single-phase	MOTOR P <sub>N</sub> kW TYPE 1x230 V		e-SM SET * P <sub>1</sub> kW * I 208-240 V A		Q = DELIVERY							
					l/min 0	70,0	140,0	210,0	280,0	350,0	420,0	483,3
					m <sup>3</sup> /h 0	4,2	8,4	12,6	16,8	21,0	25,2	29,0
H = TOTAL HEAD IN METRES OF COLUMN OF WATER												
15HME01S11M02	1,1	ESM80/111 HM..	1 x 1,33	5,85	20,9	20,5	19,7	18,8	16,4	12,7	8,8	5,2
15HME02S15M02	1,5	ESM80/115 HM..	1 x 1,79	7,85	42,7	41,8	35,9	29,8	24,2	18,2	11,3	5,1

Table refers to hydraulic performances with one pump running, max rpm, friction loss not included

g10\_1-15hmes-esm-2p50-en\_a\_th

\* Maximum value in specified range: P<sub>1</sub> = input power; I = input nominal current absorbed by set

\*\* For technical details see technical catalogue of single electric pump

## ELECTRIC PUMP SINGLE-PHASE TABLE OF ELECTRIC MOTOR DATA

In the range 3000-3600 rpm the nominal motor power is guaranteed. Above 3600 rpm it isn't possible work and the motor is automatically limited; below 3000 rpm it works partially load.

### e-SVE

P <sub>N</sub> kW	MOTOR TYPE	IEC SIZE*	Construction Design	SPEED (RPM)** min <sup>-1</sup>	INPUT CURRENT I (A) 208-240 V	DATA RELATED TO THE VOLTAGE OF 230V					IES	
						In A	cosφ	Tn Nm	η %			
								4/4	3/4	2/4		
0,37	ESM90R/103 SVE	90R	V18/B14	3000	2,28-1,99	2,08	0,95	1,18	81,3	79,1	74,3	2
				3600	2,30-2,02	2,10		0,98	80,6	77,5	72,0	
0,55	ESM90R/105 SVE	90R		3000	3,27-2,85	2,96	0,97	1,75	83,3	82,2	78,8	2
				3600	3,27-2,85	2,96		1,46	83,3	81,5	77,5	
0,75	ESM90R/107 SVE	90R		3000	4,43-3,84	4,00	0,98	2,39	83,3	83,3	81,5	2
				3600	4,38-3,79	3,94		1,99	84,5	83,5	80,6	
1,10	ESM90R/111 SVE	90R		3000	6,26-5,35	5,64	0,99	3,50	85,7	85,1	82,7	2
				3600	6,20-5,32	5,63		2,92	85,9	84,6	81,4	
1,50	ESM90R/115 SVE	90R		3000	8,57-7,32	7,69	0,99	4,77	85,6	85,7	84,7	2
				3600	8,42-7,25	7,62		3,98	86,3	85,9	84,0	

\* R = Reduced size of motor casing as compared to shaft extension and flange.

eSV\_Smart-motm\_en\_a\_te

\*\* The indicated rotational speed are representing the upper and lower limits of the rated power operational speed range.

### VME, e-HME

P <sub>N</sub> kW	MOTOR TYPE	IEC SIZE*	Construction Design	SPEED (RPM)* min <sup>-1</sup>	INPUT CURRENT I (A) 208-240 V	DATA RELATED TO THE VOLTAGE OF 230V					IES	
						In A	cosφ	Tn Nm	η %			
								4/4	3/4	2/4		
0,37	ESM80/103 HM..	80	SPECIAL	3000	2,28-1,99	2,08	0,95	1,18	81,3	79,1	74,3	2
				3600	2,30-2,02	2,10		0,98	80,6	77,5	72,0	
0,55	ESM80/105 HM..	80		3000	3,27-2,85	2,96	0,97	1,75	83,3	82,2	78,8	2
				3600	3,27-2,85	2,96		1,46	83,3	81,5	77,5	
0,75	ESM80/107 HM..	80		3000	4,43-3,84	4,00	0,98	2,39	83,3	83,3	81,5	2
				3600	4,38-3,79	3,94		1,99	84,5	83,5	80,6	
1,10	ESM80/111 HM..	80		3000	6,26-5,35	5,64	0,99	3,50	85,7	85,1	82,7	2
				3600	6,20-5,32	5,63		2,92	85,9	84,6	81,4	
1,50	ESM80/115 HM..	80		3000	8,57-7,32	7,69	0,99	4,77	85,6	85,7	84,7	2
				3600	8,42-7,25	7,62		3,98	86,3	85,9	84,0	

\* The indicated rotational speed are representing the upper and lower limits of the rated power operational speed range.

eHM-eVM\_Smart-motm\_en\_a\_te

## SMB20/..SVE BOOSTER SETS SERIES SINGLE-PHASE TABLE OF HYDRAULIC PERFORMANCE

** PUMP TYPE SVE Single-phase	MOTOR		SMB20 SET		Q = DELIVERY							
	P <sub>N</sub> kW	TYPE 1x230 V	* P <sub>1</sub> kW	* I 208-240 V A	l/min 0	13,3	26,7	40,0	53,3	66,7	80,0	93,3
					m <sup>3</sup> /h 0	0,8	1,6	2,4	3,2	4,0	4,8	5,6
H = TOTAL HEAD IN METRES OF COLUMN OF WATER												
1SVE05..003	0,37	ESM90R/103 SVE	2 x 0,49	4,48	44,7	45,0	45,2	44,6	41,5	35,0	28,1	20,8
1SVE08..005	0,55	ESM90R/105 SVE	2 x 0,68	6,14	71,5	72,0	72,3	71,2	62,3	52,0	41,2	29,6
1SVE11..007	0,75	ESM90R/107 SVE	2 x 0,91	8,08	98,3	99,1	99,3	97,7	85,1	70,9	56,0	40,0
1SVE15..011	1,1	ESM90R/111 SVE	2 x 1,33	11,70	134,1	135,1	135,5	133,8	123,6	103,9	83,3	61,4

** PUMP TYPE SVE Single-phase	MOTOR		SMB20 SET		Q = DELIVERY							
	P <sub>N</sub> kW	TYPE 1x230 V	* P <sub>1</sub> kW	* I 208-240 V A	l/min 0	26,7	53,3	80,0	106,7	133,3	160,0	173,3
					m <sup>3</sup> /h 0	1,6	3,2	4,8	6,4	8,0	9,6	10,4
H = TOTAL HEAD IN METRES OF COLUMN OF WATER												
3SVE03..003	0,37	ESM90R/103 SVE	2 x 0,49	4,48	33,4	33,7	33,6	30,7	24,9	19,5	14,0	10,9
3SVE05..005	0,55	ESM90R/105 SVE	2 x 0,69	6,16	55,7	56,2	55,8	46,3	37,1	28,4	19,5	14,4
3SVE07..007	0,75	ESM90R/107 SVE	2 x 0,92	8,12	77,9	78,7	77,2	63,4	50,7	38,6	26,0	18,7
3SVE09..011	1,1	ESM90R/111 SVE	2 x 1,33	11,70	100,2	101,0	100,5	88,8	72,5	56,4	39,9	31,2
3SVE11..015	1,5	ESM90R/115 SVE	2 x 1,78	15,60	122,5	123,3	122,5	117,9	98,4	78,0	57,2	46,3

** PUMP TYPE SVE Single-phase	MOTOR		SMB20 SET		Q = DELIVERY							
	P <sub>N</sub> kW	TYPE 1x230 V	* P <sub>1</sub> kW	* I 208-240 V A	l/min 0	46,7	93,3	140,0	186,7	233,3	280,0	333,3
					m <sup>3</sup> /h 0	2,8	5,6	8,4	11,2	14,0	16,8	20,0
H = TOTAL HEAD IN METRES OF COLUMN OF WATER												
5SVE02..003	0,37	ESM90R/103 SVE	2 x 0,49	4,48	22,4	22,2	21,8	20,0	16,5	13,3	10,2	6,5
5SVE03..005	0,55	ESM90R/105 SVE	2 x 0,68	6,14	33,5	33,3	32,7	29,8	24,5	19,8	15,2	9,5
5SVE04..007	0,75	ESM90R/107 SVE	2 x 0,91	8,10	44,7	44,4	43,5	40,5	33,4	27,1	20,8	13,3
5SVE06..011	1,1	ESM90R/111 SVE	2 x 1,33	11,72	67,1	66,6	65,3	59,5	49,0	39,6	30,4	19,1
5SVE08..015	1,5	ESM90R/115 SVE	2 x 1,78	15,62	88,8	89,3	87,6	82,6	68,3	55,3	42,6	27,9

** PUMP TYPE SVE Single-phase	MOTOR		SMB20 SET		Q = DELIVERY							
	P <sub>N</sub> kW	TYPE 1x230 V	* P <sub>1</sub> kW	* I 208-240 V A	l/min 0	80,0	160,0	240,0	320,0	400,0	480,0	566,7
					m <sup>3</sup> /h 0	4,8	9,6	14,4	19,2	24,0	28,8	34,0
H = TOTAL HEAD IN METRES OF COLUMN OF WATER												
10SVE01..005	0,55	ESM90R/105 SVE	2 x 0,68	6,14	17,3	17,3	16,9	16,2	13,6	10,4	7,1	3,3
10SVE02..007	0,75	ESM90R/107 SVE	2 x 0,92	8,18	24,2	23,9	23,1	21,7	19,3	14,6	9,7	3,6
10SVE02..011	1,1	ESM90R/111 SVE	2 x 1,33	11,70	34,8	34,5	33,7	32,3	27,7	22,4	17,1	11,0
10SVE03..015	1,5	ESM90R/115 SVE	2 x 1,78	15,62	52,7	52,2	51,0	46,1	38,1	30,8	23,5	15,1

** PUMP TYPE SVE Single-phase	MOTOR		SMB20 SET		Q = DELIVERY							
	P <sub>N</sub> kW	TYPE 1x230 V	* P <sub>1</sub> kW	* I 208-240 V A	l/min 0	140,0	280,0	420,0	560,0	700,0	840,0	966,7
					m <sup>3</sup> /h 0	8,4	16,8	25,2	33,6	42,0	50,4	58,0
H = TOTAL HEAD IN METRES OF COLUMN OF WATER												
15SVE01..007	0,75	ESM90R/107 SVE	2 x 0,92	8,20	14,2	13,9	13,3	12,3	9,8	6,4	2,8	
15SVE01..011	1,1	ESM90R/111 SVE	2 x 1,33	11,70	20,5	20,1	19,4	18,4	14,8	10,9	7,0	3,2
15SVE02..015	1,5	ESM90R/115 SVE	2 x 1,76	15,42	29,6	29,1	28,3	26,8	22,2	16,4	10,1	3,8

** PUMP TYPE SVE Single-phase	MOTOR		SMB20 SET		Q = DELIVERY							
	P <sub>N</sub> kW	TYPE 1x230 V	* P <sub>1</sub> kW	* I 208-240 V A	l/min 0	140,0	280,0	420,0	560,0	700,0	840,0	1000,0
					m <sup>3</sup> /h 0	8,4	16,8	25,2	33,6	42,0	50,4	60,0
H = TOTAL HEAD IN METRES OF COLUMN OF WATER												
22SVE01..007	0,75	ESM90R/107 SVE	2 x 0,89	7,90	14,4	14,4	14,1	12,5	9,5	6,3	2,9	
22SVE01..011	1,1	ESM90R/111 SVE	2 x 1,34	11,74	20,7	20,8	20,5	18,7	15,1	11,5	7,8	3,2
22SVE02..015	1,5	ESM90R/115 SVE	2 x 1,72	15,12	31,4	31,0	30,3	26,7	21,7	16,7	11,0	2,8

Table refers to hydraulic performances with two pumps running, max rpm, friction loss not included

g20\_1-22sve-esm-2p50-en\_a\_th

\* Maximum value in specified range: P<sub>1</sub> = input power; I = input nominal current absorbed by set

\*\* For technical details see see technical catalogue of single electric pump

## SMB20/..VME BOOSTER SETS SERIES SINGLE-PHASE TABLE OF HYDRAULIC PERFORMANCE

** PUMP TYPE VME Single-phase	MOTOR		SMB20 SET		Q = DELIVERY							
	P <sub>N</sub> kW	TYPE 1x230 V	* P <sub>1</sub> kW	* I 208-240 V A	l/min 0	13,3	26,7	40,0	53,3	66,7	80,0	100,0
					m <sup>3</sup> /h 0	0,8	1,6	2,4	3,2	4,0	4,8	6,0
H = TOTAL HEAD IN METRES OF COLUMN OF WATER												
1VME02P03	0,37	ESM80/103 HM..	2 x 0,49	4,48	34,4	33,3	32,1	30,6	28,3	24,4	20,4	14,6
1VME04P05	0,55	ESM80/105 HM..	2 x 0,69	6,14	57,5	55,3	53,1	50,4	46,7	39,3	32,0	21,9
1VME05P07	0,75	ESM80/107 HM..	2 x 0,91	8,08	80,8	78,0	75,0	71,7	63,0	53,5	44,1	30,8
1VME06P11	1,1	ESM80/111 HM..	2 x 1,33	11,70	99,8	96,3	92,8	88,5	83,2	76,1	65,5	47,9

** PUMP TYPE VME Single-phase	MOTOR		SMB20 SET		Q = DELIVERY							
	P <sub>N</sub> kW	TYPE 1x230 V	* P <sub>1</sub> kW	* I 208-240 V A	l/min 0	26,7	53,3	80,0	106,7	133,3	160,0	173,3
					m <sup>3</sup> /h 0	1,6	3,2	4,8	6,4	8,0	9,6	10,4
H = TOTAL HEAD IN METRES OF COLUMN OF WATER												
3VME02P03	0,37	ESM80/103 HM..	2 x 0,49	4,48	35,5	34,3	31,2	25,0	19,5	14,5	9,8	7,5
3VME03P05	0,55	ESM80/105 HM..	2 x 0,69	6,14	53,2	51,3	47,1	37,9	29,8	22,7	16,1	12,4
3VME04P07	0,75	ESM80/107 HM..	2 x 0,91	8,12	70,9	68,3	63,9	51,6	40,6	31,1	22,3	17,3
3VME05P11	1,1	ESM80/111 HM..	2 x 1,33	11,70	88,6	85,5	82,4	74,3	59,5	46,6	34,8	28,8
3VME06P15	1,5	ESM80/115 HM..	2 x 1,78	15,56	100,5	96,8	93,2	86,6	77,0	64,1	49,3	42,0

** PUMP TYPE VME Single-phase	MOTOR		SMB20 SET		Q = DELIVERY							
	P <sub>N</sub> kW	TYPE 1x230 V	* P <sub>1</sub> kW	* I 208-240 V A	l/min 0	40,0	80,0	120,0	160,0	200,0	240,0	280,0
					m <sup>3</sup> /h 0	2,4	4,8	7,2	9,6	12,0	14,4	16,8
H = TOTAL HEAD IN METRES OF COLUMN OF WATER												
5VME02P05	0,55	ESM80/105 HM..	2 x 0,69	6,14	36,3	34,8	33,4	29,1	23,4	18,7	14,1	8,9
5VME03P07	0,75	ESM80/107 HM..	2 x 0,92	8,12	54,2	52,4	49,8	39,9	32,5	25,8	18,8	11,5
5VME04P11	1,1	ESM80/111 HM..	2 x 1,33	11,70	72,3	69,9	66,3	57,8	47,4	38,2	28,6	18,6
5VME05P15	1,5	ESM80/115 HM..	2 x 1,78	15,60	90,4	87,4	82,9	77,9	64,2	52,3	40,1	27,3

** PUMP TYPE VME Single-phase	MOTOR		SMB20 SET		Q = DELIVERY							
	P <sub>N</sub> kW	TYPE 1x230 V	* P <sub>1</sub> kW	* I 208-240 V A	l/min 0	80,0	160,0	240,0	320,0	400,0	480,0	566,7
					m <sup>3</sup> /h 0	4,8	9,6	14,4	19,2	24,0	28,8	34,0
H = TOTAL HEAD IN METRES OF COLUMN OF WATER												
10VME01P07	0,75	ESM80/107 HM..	2 x 0,91	8,08	22,6	22,2	21,2	20,0	16,6	13,5	10,4	6,8
10VME02P11	1,1	ESM80/111 HM..	2 x 1,34	11,72	38,0	37,2	35,4	30,7	24,7	19,2	13,4	6,7

Table refers to hydraulic performances with two pumps running, max rpm, friction loss not included

g20\_1-10vme-esm-2p50-en\_a\_th

\* Maximum value in specified range: P<sub>1</sub> = input power; I = input nominal current absorbed by set

\*\* For technical details see see technical catalogue of single electric pump

## SMB20/..HME BOOSTER SETS SERIES SINGLE-PHASE TABLE OF HYDRAULIC PERFORMANCE

** PUMP TYPE HME..S, HME..N Single-phase	MOTOR		SMB20 SET		Q = DELIVERY							
	P <sub>N</sub> kW	TYPE 1x230 V	* P <sub>1</sub> kW	* I 208-240 V A	l/min 0	13,3	26,7	40,0	53,3	66,7	80,0	93,3
					m <sup>3</sup> /h 0	0,8	1,6	2,4	3,2	4,0	4,8	5,6
H = TOTAL HEAD IN METRES OF COLUMN OF WATER												
1HME05S03	0,37	ESM80/103 HM..	2 x 0,49	4,48	44,7	44,8	44,9	44,1	39,2	32,5	25,7	18,9
1HME08S05	0,55	ESM80/105 HM..	2 x 0,69	6,14	71,6	71,5	71,7	70,4	60,3	50,0	39,6	29,0
1HME11S07	0,75	ESM80/107 HM..	2 x 0,91	8,08	98,5	98,5	98,8	94,3	80,7	66,8	52,9	38,6
1HME15S11	1,1	ESM80/111 HM..	2 x 1,33	11,70	134,0	134,4	134,6	132,3	119,5	99,5	79,6	59,6
1HME17S15	1,5	ESM80/115 HM..	2 x 1,77	15,54	151,8	152,2	152,7	149,6	141,6	128,6	110,7	87,2

** PUMP TYPE HME..S, HME..N Single-phase	MOTOR		SMB20 SET		Q = DELIVERY							
	P <sub>N</sub> kW	TYPE 1x230 V	* P <sub>1</sub> kW	* I 208-240 V A	l/min 0	26,7	53,3	80,0	106,7	133,3	160,0	173,3
					m <sup>3</sup> /h 0	1,6	3,2	4,8	6,4	8,0	9,6	10,4
H = TOTAL HEAD IN METRES OF COLUMN OF WATER												
3HME03S03	0,37	ESM80/103 HM..	2 x 0,49	4,48	33,3	33,9	33,4	31,5	25,6	20,1	14,6	11,8
3HME05S05	0,55	ESM80/105 HM..	2 x 0,69	6,14	55,5	56,5	55,7	47,5	38,2	29,4	20,5	16,0
3HME07S07	0,75	ESM80/107 HM..	2 x 0,91	8,12	77,6	79,1	78,1	64,9	52,0	39,8	27,5	21,3
3HME09S11	1,1	ESM80/111 HM..	2 x 1,33	11,70	99,8	101,8	100,3	93,6	76,1	59,6	43,0	34,7
3HME12S15	1,5	ESM80/115 HM..	2 x 1,78	15,60	133,1	135,9	133,6	127,3	103,6	81,5	59,2	48,1

** PUMP TYPE HME..S, HME..N Single-phase	MOTOR		SMB20 SET		Q = DELIVERY							
	P <sub>N</sub> kW	TYPE 1x230 V	* P <sub>1</sub> kW	* I 208-240 V A	l/min 0	46,7	93,3	140,0	186,7	233,3	280,0	340,0
					m <sup>3</sup> /h 0	2,8	5,6	8,4	11,2	14,0	16,8	20,4
H = TOTAL HEAD IN METRES OF COLUMN OF WATER												
5HME02S03	0,37	ESM80/103 HM..	2 x 0,49	4,48	22,2	22,4	21,9	19,8	16,2	13,0	9,9	6,0
5HME03S05	0,55	ESM80/105 HM..	2 x 0,69	6,14	33,3	33,6	32,9	29,5	24,1	19,3	14,7	8,8
5HME04S07	0,75	ESM80/107 HM..	2 x 0,91	8,10	44,4	44,7	43,8	40,1	32,8	26,4	20,2	12,2
5HME06S11	1,1	ESM80/111 HM..	2 x 1,33	11,70	66,7	67,2	65,8	59,0	48,1	38,7	29,5	17,5
5HME08S15	1,5	ESM80/115 HM..	2 x 1,78	15,64	88,9	89,5	87,7	80,2	65,5	52,8	40,4	24,4

** PUMP TYPE HME..S, HME..N Single-phase	MOTOR		SMB20 SET		Q = DELIVERY							
	P <sub>N</sub> kW	TYPE 1x230 V	* P <sub>1</sub> kW	* I 208-240 V A	l/min 0	80,0	160,0	240,0	320,0	400,0	480,0	566,7
					m <sup>3</sup> /h 0	4,8	9,6	14,4	19,2	24,0	28,8	34,0
H = TOTAL HEAD IN METRES OF COLUMN OF WATER												
10HME01S07	0,75	ESM80/107 HM..	2 x 0,86	7,60	17,5	17,5	17,0	16,1	14,7	12,7	10,2	6,6
10HME02S11	1,1	ESM80/111 HM..	2 x 1,33	11,70	34,8	34,9	33,8	32,3	27,2	21,9	16,6	11,1
10HME03S15	1,5	ESM80/115 HM..	2 x 1,78	15,62	52,4	51,8	50,6	46,9	39,2	32,2	25,3	17,8

** PUMP TYPE HME..S, HME..N Single-phase	MOTOR		SMB20 SET		Q = DELIVERY							
	P <sub>N</sub> kW	TYPE 1x230 V	* P <sub>1</sub> kW	* I 208-240 V A	l/min 0	140,0	280,0	420,0	560,0	700,0	840,0	966,7
					m <sup>3</sup> /h 0	8,4	16,8	25,2	33,6	42,0	50,4	58,0
H = TOTAL HEAD IN METRES OF COLUMN OF WATER												
15HME01S11M02	1,1	ESM80/111 HM..	2 x 1,33	11,70	20,9	20,5	19,7	18,8	16,4	12,7	8,8	5,2
15HME02S15M02	1,5	ESM80/115 HM..	2 x 1,79	15,70	42,7	41,8	35,9	29,8	24,2	18,2	11,3	5,1

Table refers to hydraulic performances with two pumps running, max rpm, friction loss not included

g20\_1-15hmes-esm-2p50-en\_a\_th

\* Maximum value in specified range: P<sub>1</sub> = input power; I = input nominal current absorbed by set

\*\* For technical details see see technical catalogue of single electric pump

## SMB30/..SVE BOOSTER SETS SERIES SINGLE-PHASE TABLE OF HYDRAULIC PERFORMANCE

** PUMP TYPE SVE Single-phase	MOTOR		SMB30 SET		Q = DELIVERY							
	P <sub>N</sub> kW	TYPE 1x230 V	* P <sub>1</sub> kW	* I 208-240 V A	l/min 0	20,0	40,0	60,0	80,0	100,0	120,0	140,0
					m <sup>3</sup> /h 0	1,2	2,4	3,6	4,8	6,0	7,2	8,4
H = TOTAL HEAD IN METRES OF COLUMN OF WATER												
1SVE05..003	0,37	ESM90R/103 SVE	3 x 0,49	6,72	44,7	45,0	45,2	44,6	41,5	35,0	28,1	20,8
1SVE08..005	0,55	ESM90R/105 SVE	3 x 0,68	9,21	71,5	72,0	72,3	71,2	62,3	52,0	41,2	29,6
1SVE11..007	0,75	ESM90R/107 SVE	3 x 0,91	12,12	98,3	99,1	99,3	97,7	85,1	70,9	56,0	40,0
1SVE15..011	1,1	ESM90R/111 SVE	3 x 1,33	17,55	134,1	135,1	135,5	133,8	123,6	103,9	83,3	61,4

** PUMP TYPE SVE Single-phase	MOTOR		SMB30 SET		Q = DELIVERY							
	P <sub>N</sub> kW	TYPE 1x230 V	* P <sub>1</sub> kW	* I 208-240 V A	l/min 0	40,0	80,0	120,0	160,0	200,0	240,0	260,0
					m <sup>3</sup> /h 0	2,4	4,8	7,2	9,6	12,0	14,4	15,6
H = TOTAL HEAD IN METRES OF COLUMN OF WATER												
3SVE03..003	0,37	ESM90R/103 SVE	3 x 0,49	6,72	33,4	33,7	33,6	30,7	24,9	19,5	14,0	10,9
3SVE05..005	0,55	ESM90R/105 SVE	3 x 0,69	9,24	55,7	56,2	55,8	46,3	37,1	28,4	19,5	14,4
3SVE07..007	0,75	ESM90R/107 SVE	3 x 0,92	12,18	77,9	78,7	77,2	63,4	50,7	38,6	26,0	18,7
3SVE09..011	1,1	ESM90R/111 SVE	3 x 1,33	17,55	100,2	101,0	100,5	88,8	72,5	56,4	39,9	31,2
3SVE11..015	1,5	ESM90R/115 SVE	3 x 1,78	23,40	122,5	123,3	122,5	117,9	98,4	78,0	57,2	46,3

** PUMP TYPE SVE Single-phase	MOTOR		SMB30 SET		Q = DELIVERY							
	P <sub>N</sub> kW	TYPE 1x230 V	* P <sub>1</sub> kW	* I 208-240 V A	l/min 0	70,0	140,0	210,0	280,0	350,0	420,0	500,0
					m <sup>3</sup> /h 0	4,2	8,4	12,6	16,8	21,0	25,2	30,0
H = TOTAL HEAD IN METRES OF COLUMN OF WATER												
5SVE02..003	0,37	ESM90R/103 SVE	3 x 0,49	6,72	22,4	22,2	21,8	20,0	16,5	13,3	10,2	6,5
5SVE03..005	0,55	ESM90R/105 SVE	3 x 0,68	9,21	33,5	33,3	32,7	29,8	24,5	19,8	15,2	9,5
5SVE04..007	0,75	ESM90R/107 SVE	3 x 0,91	12,15	44,7	44,4	43,5	40,5	33,4	27,1	20,8	13,3
5SVE06..011	1,1	ESM90R/111 SVE	3 x 1,33	17,58	67,1	66,6	65,3	59,5	49,0	39,6	30,4	19,1
5SVE08..015	1,5	ESM90R/115 SVE	3 x 1,78	23,43	88,8	89,3	87,6	82,6	68,3	55,3	42,6	27,9

** PUMP TYPE SVE Single-phase	MOTOR		SMB30 SET		Q = DELIVERY							
	P <sub>N</sub> kW	TYPE 1x230 V	* P <sub>1</sub> kW	* I 208-240 V A	l/min 0	120,0	240,0	360,0	480,0	600,0	720,0	850,0
					m <sup>3</sup> /h 0	7,2	14,4	21,6	28,8	36,0	43,2	51,0
H = TOTAL HEAD IN METRES OF COLUMN OF WATER												
10SVE01..005	0,55	ESM90R/105 SVE	3 x 0,68	9,21	17,3	17,3	16,9	16,2	13,6	10,4	7,1	3,3
10SVE02..007	0,75	ESM90R/107 SVE	3 x 0,92	12,27	24,2	23,9	23,1	21,7	19,3	14,6	9,7	3,6
10SVE02..011	1,1	ESM90R/111 SVE	3 x 1,33	17,55	34,8	34,5	33,7	32,3	27,7	22,4	17,1	11,0
10SVE03..015	1,5	ESM90R/115 SVE	3 x 1,78	23,43	52,7	52,2	51,0	46,1	38,1	30,8	23,5	15,1

** PUMP TYPE SVE Single-phase	MOTOR		SMB30 SET		Q = DELIVERY							
	P <sub>N</sub> kW	TYPE 1x230 V	* P <sub>1</sub> kW	* I 208-240 V A	l/min 0	210,0	420,0	630,0	840,0	1050,0	1260,0	1450,0
					m <sup>3</sup> /h 0	12,6	25,2	37,8	50,4	63,0	75,6	87,0
H = TOTAL HEAD IN METRES OF COLUMN OF WATER												
15SVE01..007	0,75	ESM90R/107 SVE	3 x 0,92	12,30	14,2	13,9	13,3	12,3	9,8	6,4	2,8	
15SVE01..011	1,1	ESM90R/111 SVE	3 x 1,33	17,55	20,5	20,1	19,4	18,4	14,8	10,9	7,0	3,2
15SVE02..015	1,5	ESM90R/115 SVE	3 x 1,76	23,13	29,6	29,1	28,3	26,8	22,2	16,4	10,1	3,8

** PUMP TYPE SVE Single-phase	MOTOR		SMB30 SET		Q = DELIVERY							
	P <sub>N</sub> kW	TYPE 1x230 V	* P <sub>1</sub> kW	* I 208-240 V A	l/min 0	210,0	420,0	630,0	840,0	1050,0	1260,0	1500,0
					m <sup>3</sup> /h 0	12,6	25,2	37,8	50,4	63,0	75,6	90,0
H = TOTAL HEAD IN METRES OF COLUMN OF WATER												
22SVE01..007	0,75	ESM90R/107 SVE	3 x 0,89	11,85	14,4	14,4	14,1	12,5	9,5	6,3	2,9	
22SVE01..011	1,1	ESM90R/111 SVE	3 x 1,34	17,61	20,7	20,8	20,5	18,7	15,1	11,5	7,8	3,2
22SVE02..015	1,5	ESM90R/115 SVE	3 x 1,72	22,68	31,4	31,0	30,3	26,7	21,7	16,7	11,0	2,8

Table refers to hydraulic performances with three pumps running, max rpm, friction loss not included

g30\_1-22sve-esm-2p50-en\_a\_th

\* Maximum value in specified range: P<sub>1</sub> = input power; I = input nominal current absorbed by set

\*\* For technical details see see technical catalogue of single electric pump

## SMB30/..VME BOOSTER SETS SERIES SINGLE-PHASE TABLE OF HYDRAULIC PERFORMANCE

** PUMP TYPE VME Single-phase	MOTOR		SMB30 SET		Q = DELIVERY							
	P <sub>N</sub> kW	TYPE 1x230 V	* P <sub>1</sub> kW	* I 208-240 V A	l/min 0	20,0	40,0	60,0	80,0	100,0	120,0	150,0
					m <sup>3</sup> /h 0	1,2	2,4	3,6	4,8	6,0	7,2	9,0
H = TOTAL HEAD IN METRES OF COLUMN OF WATER												
1VME02P03	0,37	ESM80/103 HM..	3 x 0,49	6,72	34,4	33,3	32,1	30,6	28,3	24,4	20,4	14,6
1VME04P05	0,55	ESM80/105 HM..	3 x 0,69	9,21	57,5	55,3	53,1	50,4	46,7	39,3	32,0	21,9
1VME05P07	0,75	ESM80/107 HM..	3 x 0,91	12,12	80,8	78,0	75,0	71,7	63,0	53,5	44,1	30,8
1VME06P11	1,1	ESM80/111 HM..	3 x 1,33	17,55	99,8	96,3	92,8	88,5	83,2	76,1	65,5	47,9

** PUMP TYPE VME Single-phase	MOTOR		SMB30 SET		Q = DELIVERY							
	P <sub>N</sub> kW	TYPE 1x230 V	* P <sub>1</sub> kW	* I 208-240 V A	l/min 0	40,0	80,0	120,0	160,0	200,0	240,0	260,0
					m <sup>3</sup> /h 0	2,4	4,8	7,2	9,6	12,0	14,4	15,6
H = TOTAL HEAD IN METRES OF COLUMN OF WATER												
3VME02P03	0,37	ESM80/103 HM..	3 x 0,49	6,72	35,5	34,3	31,2	25,0	19,5	14,5	9,8	7,5
3VME03P05	0,55	ESM80/105 HM..	3 x 0,69	9,21	53,2	51,3	47,1	37,9	29,8	22,7	16,1	12,4
3VME04P07	0,75	ESM80/107 HM..	3 x 0,91	12,18	70,9	68,3	63,9	51,6	40,6	31,1	22,3	17,3
3VME05P11	1,1	ESM80/111 HM..	3 x 1,33	17,55	88,6	85,5	82,4	74,3	59,5	46,6	34,8	28,8
3VME06P15	1,5	ESM80/115 HM..	3 x 1,78	23,34	100,5	96,8	93,2	86,6	77,0	64,1	49,3	42,0

** PUMP TYPE VME Single-phase	MOTOR		SMB30 SET		Q = DELIVERY							
	P <sub>N</sub> kW	TYPE 1x230 V	* P <sub>1</sub> kW	* I 208-240 V A	l/min 0	60,0	120,0	180,0	240,0	300,0	360,0	420,0
					m <sup>3</sup> /h 0	3,6	7,2	10,8	14,4	18,0	21,6	25,2
H = TOTAL HEAD IN METRES OF COLUMN OF WATER												
5VME02P05	0,55	ESM80/105 HM..	3 x 0,69	9,21	36,3	34,8	33,4	29,1	23,4	18,7	14,1	8,9
5VME03P07	0,75	ESM80/107 HM..	3 x 0,92	12,18	54,2	52,4	49,8	39,9	32,5	25,8	18,8	11,5
5VME04P11	1,1	ESM80/111 HM..	3 x 1,33	17,55	72,3	69,9	66,3	57,8	47,4	38,2	28,6	18,6
5VME05P15	1,5	ESM80/115 HM..	3 x 1,78	23,40	90,4	87,4	82,9	77,9	64,2	52,3	40,1	27,3

** PUMP TYPE VME Single-phase	MOTOR		SMB30 SET		Q = DELIVERY							
	P <sub>N</sub> kW	TYPE 1x230 V	* P <sub>1</sub> kW	* I 208-240 V A	l/min 0	120,0	240,0	360,0	480,0	600,0	720,0	850,0
					m <sup>3</sup> /h 0	7,2	14,4	21,6	28,8	36,0	43,2	51,0
H = TOTAL HEAD IN METRES OF COLUMN OF WATER												
10VME01P07	0,75	ESM80/107 HM..	3 x 0,91	12,12	22,6	22,2	21,2	20,0	16,6	13,5	10,4	6,8
10VME02P11	1,1	ESM80/111 HM..	3 x 1,34	17,58	38,0	37,2	35,4	30,7	24,7	19,2	13,4	6,7

Table refers to hydraulic performances with three pumps running, max rpm, friction loss not included

g30\_1-10vme-esm-2p50-en\_a\_th

\* Maximum value in specified range: P<sub>1</sub> = input power; I = input nominal current absorbed by set

\*\* For technical details see see technical catalogue of single electric pump

## SMB30/..HME BOOSTER SETS SERIES SINGLE-PHASE TABLE OF HYDRAULIC PERFORMANCE

** PUMP TYPE HME..S, HME..N Single-phase	MOTOR		SMB30 SET		Q = DELIVERY							
	P <sub>N</sub> kW	TYPE 1x230 V	* P <sub>1</sub> kW	* I 208-240 V A	l/min 0	20,0	40,0	60,0	80,0	100,0	120,0	140,0
					m <sup>3</sup> /h 0	1,2	2,4	3,6	4,8	6,0	7,2	8,4
H = TOTAL HEAD IN METRES OF COLUMN OF WATER												
1HME05S03	0,37	ESM80/103 HM..	3 x 0,49	6,72	44,7	44,8	44,9	44,1	39,2	32,5	25,7	18,9
1HME08S05	0,55	ESM80/105 HM..	3 x 0,69	9,21	71,6	71,5	71,7	70,4	60,3	50,0	39,6	29,0
1HME11S07	0,75	ESM80/107 HM..	3 x 0,91	12,12	98,5	98,5	98,8	94,3	80,7	66,8	52,9	38,6
1HME15S11	1,1	ESM80/111 HM..	3 x 1,33	17,55	134,0	134,4	134,6	132,3	119,5	99,5	79,6	59,6
1HME17S15	1,5	ESM80/115 HM..	3 x 1,77	23,31	151,8	152,2	152,7	149,6	141,6	128,6	110,7	87,2

** PUMP TYPE HME..S, HME..N Single-phase	MOTOR		SMB30 SET		Q = DELIVERY							
	P <sub>N</sub> kW	TYPE 1x230 V	* P <sub>1</sub> kW	* I 208-240 V A	l/min 0	40,0	80,0	120,0	160,0	200,0	240,0	260,0
					m <sup>3</sup> /h 0	2,4	4,8	7,2	9,6	12,0	14,4	15,6
H = TOTAL HEAD IN METRES OF COLUMN OF WATER												
3HME03S03	0,37	ESM80/103 HM..	3 x 0,49	6,72	33,3	33,9	33,4	31,5	25,6	20,1	14,6	11,8
3HME05S05	0,55	ESM80/105 HM..	3 x 0,69	9,21	55,5	56,5	55,7	47,5	38,2	29,4	20,5	16,0
3HME07S07	0,75	ESM80/107 HM..	3 x 0,91	12,18	77,6	79,1	78,1	64,9	52,0	39,8	27,5	21,3
3HME09S11	1,1	ESM80/111 HM..	3 x 1,33	17,55	99,8	101,8	100,3	93,6	76,1	59,6	43,0	34,7
3HME12S15	1,5	ESM80/115 HM..	3 x 1,78	23,40	133,1	135,9	133,6	127,3	103,6	81,5	59,2	48,1

** PUMP TYPE HME..S, HME..N Single-phase	MOTOR		SMB30 SET		Q = DELIVERY							
	P <sub>N</sub> kW	TYPE 1x230 V	* P <sub>1</sub> kW	* I 208-240 V A	l/min 0	70,0	140,0	210,0	280,0	350,0	420,0	510,0
					m <sup>3</sup> /h 0	4,2	8,4	12,6	16,8	21,0	25,2	30,6
H = TOTAL HEAD IN METRES OF COLUMN OF WATER												
5HME02S03	0,37	ESM80/103 HM..	3 x 0,49	6,72	22,2	22,4	21,9	19,8	16,2	13,0	9,9	6,0
5HME03S05	0,55	ESM80/105 HM..	3 x 0,69	9,21	33,3	33,6	32,9	29,5	24,1	19,3	14,7	8,8
5HME04S07	0,75	ESM80/107 HM..	3 x 0,91	12,15	44,4	44,7	43,8	40,1	32,8	26,4	20,2	12,2
5HME06S11	1,1	ESM80/111 HM..	3 x 1,33	17,55	66,7	67,2	65,8	59,0	48,1	38,7	29,5	17,5
5HME08S15	1,5	ESM80/115 HM..	3 x 1,78	23,46	88,9	89,5	87,7	80,2	65,5	52,8	40,4	24,4

** PUMP TYPE HME..S, HME..N Single-phase	MOTOR		SMB30 SET		Q = DELIVERY							
	P <sub>N</sub> kW	TYPE 1x230 V	* P <sub>1</sub> kW	* I 208-240 V A	l/min 0	120,0	240,0	360,0	480,0	600,0	720,0	850,0
					m <sup>3</sup> /h 0	7,2	14,4	21,6	28,8	36,0	43,2	51,0
H = TOTAL HEAD IN METRES OF COLUMN OF WATER												
10HME01S07	0,75	ESM80/107 HM..	3 x 0,86	11,40	17,5	17,5	17,0	16,1	14,7	12,7	10,2	6,6
10HME02S11	1,1	ESM80/111 HM..	3 x 1,33	17,55	34,8	34,9	33,8	32,3	27,2	21,9	16,6	11,1
10HME03S15	1,5	ESM80/115 HM..	3 x 1,78	23,43	52,4	51,8	50,6	46,9	39,2	32,2	25,3	17,8

** PUMP TYPE HME..S, HME..N Single-phase	MOTOR		SMB30 SET		Q = DELIVERY							
	P <sub>N</sub> kW	TYPE 1x230 V	* P <sub>1</sub> kW	* I 208-240 V A	l/min 0	210,0	420,0	630,0	840,0	1050,0	1260,0	1450,0
					m <sup>3</sup> /h 0	12,6	25,2	37,8	50,4	63,0	75,6	87,0
H = TOTAL HEAD IN METRES OF COLUMN OF WATER												
15HME01S11M02	1,1	ESM80/111 HM..	3 x 1,33	17,55	20,9	20,5	19,7	18,8	16,4	12,7	8,8	5,2
15HME02S15M02	1,5	ESM80/115 HM..	3 x 1,79	23,55	42,7	41,8	35,9	29,8	24,2	18,2	11,3	5,1

Table refers to hydraulic performances with three pumps running, max rpm, friction loss not included

g30\_1-15hmes-esm-2p50-en\_a\_th

\* Maximum value in specified range: P<sub>1</sub> = input power; I = input nominal current absorbed by set

\*\* For technical details see see technical catalogue of single electric pump

## SMB10/..SVE BOOSTER SETS SERIES THREE-PHASE TABLE OF HYDRAULIC PERFORMANCE

** PUMP TYPE SVE Three-phases	MOTOR		e-SM SET		Q = DELIVERY							
	P <sub>N</sub> kW	TYPE	* P <sub>1</sub> kW	* I 380-460 V A	l/min 0	6,7	13,3	20,0	26,7	33,3	40,0	46,7
					m <sup>3</sup> /h 0	0,4	0,8	1,2	1,6	2,0	2,4	2,8
H = TOTAL HEAD IN METRES OF COLUMN OF WATER												
1SVE05..003	0,37	ESM90R/303 SVE	1 x 0,49	1,45	44,7	45,0	45,2	44,6	41,5	34,9	28,0	20,8
1SVE08..005	0,55	ESM90R/305 SVE	1 x 0,69	1,90	71,5	72,0	72,3	71,2	62,4	52,1	41,2	29,7
1SVE11..007	0,75	ESM90R/307 SVE	1 x 0,91	2,40	98,3	99,1	99,3	97,7	85,0	70,9	56,0	40,1
1SVE15..011	1,1	ESM90R/311 SVE	1 x 1,37	3,45	134,1	135,1	135,5	133,8	123,6	104,0	83,3	61,4

** PUMP TYPE SVE Three-phases	MOTOR		e-SM SET		Q = DELIVERY							
	P <sub>N</sub> kW	TYPE	* P <sub>1</sub> kW	* I 380-460 V A	l/min 0	13,3	26,7	40,0	53,3	66,7	80,0	86,7
					m <sup>3</sup> /h 0	0,8	1,6	2,4	3,2	4,0	4,8	5,2
H = TOTAL HEAD IN METRES OF COLUMN OF WATER												
3SVE03..003	0,37	ESM90R/303 SVE	1 x 0,49	1,47	33,4	33,8	33,6	30,7	24,9	19,5	14,0	10,9
3SVE05..005	0,55	ESM90R/305 SVE	1 x 0,7	1,92	55,7	56,2	55,8	46,3	37,1	28,4	19,4	14,4
3SVE07..007	0,75	ESM90R/307 SVE	1 x 0,93	2,43	77,9	78,7	77,2	63,3	50,6	38,6	26,0	18,7
3SVE09..011	1,1	ESM90R/311 SVE	1 x 1,37	3,45	100,2	101,0	100,5	88,8	72,5	56,4	39,9	31,2
3SVE11..015	1,5	ESM90R/315 SVE	1 x 1,82	4,42	122,5	123,3	122,5	117,9	98,4	77,9	57,2	46,4

** PUMP TYPE SVE Three-phases	MOTOR		e-SM SET		Q = DELIVERY							
	P <sub>N</sub> kW	TYPE	* P <sub>1</sub> kW	* I 380-460 V A	l/min 0	23,3	46,7	70,0	93,3	116,7	140,0	166,7
					m <sup>3</sup> /h 0	1,4	2,8	4,2	5,6	7,0	8,4	10,0
H = TOTAL HEAD IN METRES OF COLUMN OF WATER												
5SVE02..003	0,37	ESM90R/303 SVE	1 x 0,5	1,48	22,4	22,2	21,8	20,0	16,5	13,3	10,2	6,5
5SVE03..005	0,55	ESM90R/305 SVE	1 x 0,69	1,92	33,5	33,3	32,7	29,8	24,5	19,8	15,2	9,5
5SVE04..007	0,75	ESM90R/307 SVE	1 x 0,92	2,42	44,7	44,4	43,5	40,5	33,4	27,0	20,8	13,3
5SVE06..011	1,1	ESM90R/311 SVE	1 x 1,38	3,46	67,1	66,6	65,3	59,5	49,0	39,6	30,3	19,1
5SVE08..015	1,5	ESM90R/315 SVE	1 x 1,83	4,43	88,8	89,2	87,6	82,7	68,4	55,3	42,7	28,0
5SVE12..022	2,2	ESM90R/322 SVE	1 x 2,55	5,88	133,2	133,7	131,6	121,6	100,4	81,0	62,2	40,3

** PUMP TYPE SVE Three-phases	MOTOR		e-SM SET		Q = DELIVERY							
	P <sub>N</sub> kW	TYPE	* P <sub>1</sub> kW	* I 380-460 V A	l/min 0	40,0	80,0	120,0	160,0	200,0	240,0	283,3
					m <sup>3</sup> /h 0	2,4	4,8	7,2	9,6	12,0	14,4	17,0
H = TOTAL HEAD IN METRES OF COLUMN OF WATER												
10SVE01..005	0,55	ESM90R/305 SVE	1 x 0,69	1,90	17,3	17,3	16,9	16,2	13,6	10,4	7,1	3,3
10SVE02..007	0,75	ESM90R/307 SVE	1 x 0,94	2,46	24,2	23,9	23,1	21,7	19,3	14,6	9,7	3,6
10SVE02..011	1,1	ESM90R/311 SVE	1 x 1,37	3,45	34,8	34,5	33,7	32,3	27,7	22,4	17,1	11,0
10SVE03..015	1,5	ESM90R/315 SVE	1 x 1,83	4,43	52,7	52,2	51,0	46,1	38,1	30,8	23,5	15,1
10SVE04..022	2,2	ESM90R/322 SVE	1 x 2,54	5,86	70,3	69,7	68,1	65,8	57,8	47,5	37,4	25,9

** PUMP TYPE SVE Three-phases	MOTOR		e-SM SET		Q = DELIVERY							
	P <sub>N</sub> kW	TYPE	* P <sub>1</sub> kW	* I 380-460 V A	l/min 0	70,0	140,0	210,0	280,0	350,0	420,0	483,3
					m <sup>3</sup> /h 0	4,2	8,4	12,6	16,8	21,0	25,2	29,0
H = TOTAL HEAD IN METRES OF COLUMN OF WATER												
15SVE01..007	0,75	ESM90R/307 SVE	1 x 0,92	2,48	14,2	13,9	13,3	12,3	9,8	6,4	2,8	0,0
15SVE01..011	1,1	ESM90R/311 SVE	1 x 1,33	3,45	20,5	20,1	19,4	18,4	14,8	10,9	7,0	3,2
15SVE02..015	1,5	ESM90R/315 SVE	1 x 1,76	4,34	29,6	29,1	28,3	26,8	22,2	16,4	10,1	3,8
15SVE02..022	2,2	ESM90R/322 SVE	1 x 2,54	5,87	42,7	42,0	41,1	39,7	33,4	26,8	20,1	13,5

** PUMP TYPE SVE Three-phases	MOTOR		e-SM SET		Q = DELIVERY							
	P <sub>N</sub> kW	TYPE	* P <sub>1</sub> kW	* I 380-460 V A	l/min 0	70,0	140,0	210,0	280,0	350,0	420,0	500,0
					m <sup>3</sup> /h 0	4,2	8,4	12,6	16,8	21,0	25,2	30,0
H = TOTAL HEAD IN METRES OF COLUMN OF WATER												
22SVE01..007	0,75	ESM90R/307 SVE	1 x 0,91	2,38	14,4	14,4	14,1	12,5	9,5	6,3	2,9	0,0
22SVE01..011	1,1	ESM90R/311 SVE	1 x 1,38	3,47	20,7	20,8	20,5	18,7	15,1	11,5	7,8	3,2
22SVE02..015	1,5	ESM90R/315 SVE	1 x 1,76	4,31	31,4	31,0	30,3	26,7	21,7	16,7	11,0	2,8
22SVE02..022	2,2	ESM90R/322 SVE	1 x 2,56	5,91	45,2	44,7	44,0	39,3	33,0	27,3	21,4	13,6

Table refers to hydraulic performances with one pump running, max rpm, friction loss not included

g10\_1-22sve-esmT-2p50-en\_a\_th

\* Maximum value in specified range; P<sub>1</sub> = input power; I = input nominal current absorbed by set

\*\* For technical details see see technical catalogue of single electric pump

## SMB10/..VME BOOSTER SETS SERIES THREE-PHASE TABLE OF HYDRAULIC PERFORMANCE

** PUMP TYPE VME Three-phases	MOTOR		e-SM SET		Q = DELIVERY							
	PN kW	TYPE	* P1 kW	* I 380-460 V A	l/min 0	6,7	13,3	20,0	26,7	33,3	40,0	50,0
					m <sup>3</sup> /h 0	0,4	0,8	1,2	1,6	2,0	2,4	3,0
H = TOTAL HEAD IN METRES OF COLUMN OF WATER												
1VME02P03T	0,37	ESM80/303 HM..	1 x 0,49	1,45	34,4	33,3	32,1	30,6	28,4	24,4	20,5	14,6
1VME04P05T	0,55	ESM80/305 HM..	1 x 0,69	1,92	57,5	55,3	53,1	50,4	46,7	39,4	32,1	21,9
1VME05P07T	0,75	ESM80/307 HM..	1 x 0,91	2,41	80,8	78,0	75,0	71,7	63,0	53,5	44,1	30,8
1VME06P11T	1,1	ESM80/311 HM..	1 x 1,37	3,44	99,8	96,3	92,8	88,5	83,2	76,1	65,4	47,9

** PUMP TYPE VME Three-phases	MOTOR		e-SM SET		Q = DELIVERY							
	PN kW	TYPE	* P1 kW	* I 380-460 V A	l/min 0	13,3	26,7	40,0	53,3	66,7	80,0	86,7
					m <sup>3</sup> /h 0	0,8	1,6	2,4	3,2	4,0	4,8	5,2
H = TOTAL HEAD IN METRES OF COLUMN OF WATER												
3VME02P03T	0,37	ESM80/303 HM..	1 x 0,5	1,48	35,5	34,3	31,2	25,1	19,5	14,5	9,8	7,5
3VME03P05T	0,55	ESM80/305 HM..	1 x 0,7	1,92	53,2	51,3	47,1	37,9	29,8	22,7	16,1	12,4
3VME04P07T	0,75	ESM80/307 HM..	1 x 0,92	2,43	70,9	68,3	64,0	51,6	40,6	31,1	22,3	17,3
3VME05P11T	1,1	ESM80/311 HM..	1 x 1,37	3,45	88,6	85,5	82,4	74,2	59,4	46,5	34,9	28,8
3VME06P15T	1,5	ESM80/315 HM..	1 x 1,81	4,40	100,5	96,8	93,2	86,6	77,0	64,1	49,3	42,0

** PUMP TYPE VME Three-phases	MOTOR		e-SM SET		Q = DELIVERY							
	PN kW	TYPE	* P1 kW	* I 380-460 V A	l/min 0	20,0	40,0	60,0	80,0	100,0	120,0	140,0
					m <sup>3</sup> /h 0	1,2	2,4	3,6	4,8	6,0	7,2	8,4
H = TOTAL HEAD IN METRES OF COLUMN OF WATER												
5VME02P05T	0,55	ESM80/305 HM..	1 x 0,69	1,91	36,3	34,8	33,4	29,1	23,5	18,7	14,1	8,9
5VME03P07T	0,75	ESM80/307 HM..	1 x 0,92	2,43	54,2	52,4	49,8	39,9	32,5	25,8	18,8	11,5
5VME04P11T	1,1	ESM80/311 HM..	1 x 1,37	3,45	72,3	69,9	66,3	57,8	47,4	38,2	28,6	18,6
5VME05P15T	1,5	ESM80/315 HM..	1 x 1,82	4,42	90,4	87,4	82,9	78,0	64,2	52,3	40,1	27,3
5VME06P22T	2,2	ESM80/322 HM..	1 x 2,33	5,44	99,6	96,1	90,9	85,3	78,6	69,2	55,6	37,2

** PUMP TYPE VME Three-phases	MOTOR		e-SM SET		Q = DELIVERY							
	PN kW	TYPE	* P1 kW	* I 380-460 V A	l/min 0	40,0	80,0	120,0	160,0	200,0	240,0	283,3
					m <sup>3</sup> /h 0	2,4	4,8	7,2	9,6	12,0	14,4	17,0
H = TOTAL HEAD IN METRES OF COLUMN OF WATER												
10VME01P07T	0,75	ESM80/307 HM..	1 x 0,91	2,40	22,6	22,2	21,2	20,0	16,6	13,5	10,4	6,8
10VME02P11T	1,1	ESM80/311 HM..	1 x 1,38	3,47	38,0	37,2	35,4	30,7	24,7	19,2	13,4	6,7

Table refers to hydraulic performances with one pump running, max rpm, friction loss not included

g10\_1-10vme-esmT-2p50-en\_a\_th

\* Maximum value in specified range: P1 = input power; I = input nominal current absorbed by set

\*\* For technical details see technical catalogue of single electric pump

## SMB10/..HME BOOSTER SETS SERIES THREE-PHASE TABLE OF HYDRAULIC PERFORMANCE

** PUMP TYPE HME..S, HME..N Three-phases	MOTOR PN TYPE KW		e-SM SET * P1 380-460 V KW A		Q = DELIVERY							
					l/min 0	6,7	13,3	20,0	26,7	33,3	40,0	46,7
					m <sup>3</sup> /h 0	0,4	0,8	1,2	1,6	2,0	2,4	2,8
H = TOTAL HEAD IN METRES OF COLUMN OF WATER												
1HME05S03	0,55	ESM80/305 HM..	1 x 0,49	1,46	44,7	44,8	44,9	44,1	39,2	32,5	25,7	19,0
1HME08S05	0,55	ESM80/305 HM..	1 x 0,69	1,90	71,6	71,5	71,7	70,4	60,3	50,0	39,6	29,0
1HME11S07	0,75	ESM80/307 HM..	1 x 0,91	2,41	98,5	98,5	98,8	94,3	80,7	66,8	52,9	38,6
1HME15S11	1,1	ESM80/311 HM..	1 x 1,37	3,45	134,0	134,4	134,6	132,3	119,5	99,6	79,6	59,6
1HME17S15	1,5	ESM80/315 HM..	1 x 1,81	4,39	151,8	152,2	152,7	149,6	141,6	128,6	110,7	87,1

** PUMP TYPE HME..S, HME..N Three-phases	MOTOR PN TYPE KW		e-SM SET * P1 380-460 V KW A		Q = DELIVERY							
					l/min 0	13,3	26,7	40,0	53,3	66,7	80,0	86,7
					m <sup>3</sup> /h 0	0,8	1,6	2,4	3,2	4,0	4,8	5,2
H = TOTAL HEAD IN METRES OF COLUMN OF WATER												
3HME03S03	0,37	ESM80/303 HM..	1 x 0,49	1,47	33,3	33,9	33,4	31,5	25,6	20,1	14,5	11,8
3HME05S05	0,55	ESM80/305 HM..	1 x 0,7	1,92	55,5	56,5	55,7	47,5	38,2	29,4	20,4	16,0
3HME07S07	0,75	ESM80/307 HM..	1 x 0,92	2,43	77,6	79,1	78,1	64,9	52,1	39,8	27,5	21,3
3HME09S11	1,1	ESM80/311 HM..	1 x 1,37	3,45	99,8	101,8	100,3	93,7	76,1	59,6	43,0	34,7
3HME12S15	1,5	ESM80/315 HM..	1 x 1,82	4,42	133,1	135,9	133,6	127,3	103,6	81,5	59,2	48,1
3HME14S22	2,2	ESM80/322 HM..	1 x 2,53	5,84	155,4	158,3	156,1	149,5	139,0	121,7	93,9	79,8

** PUMP TYPE HME..S, HME..N Three-phases	MOTOR PN TYPE KW		e-SM SET * P1 380-460 V KW A		Q = DELIVERY							
					l/min 0	23,3	46,7	70,0	93,3	116,7	140,0	170,0
					m <sup>3</sup> /h 0	1,4	2,8	4,2	5,6	7,0	8,4	10,2
H = TOTAL HEAD IN METRES OF COLUMN OF WATER												
5HME02S03	0,37	ESM80/303 HM..	1 x 0,5	1,48	22,2	22,4	21,9	19,8	16,2	13,0	9,9	6,0
5HME03S05	0,55	ESM80/305 HM..	1 x 0,7	1,92	33,3	33,6	32,9	29,5	24,1	19,3	14,7	8,8
5HME04S07	0,75	ESM80/307 HM..	1 x 0,92	2,42	44,4	44,7	43,8	40,1	32,8	26,4	20,2	12,2
5HME06S11	1,1	ESM80/311 HM..	1 x 1,38	3,46	66,7	67,2	65,8	59,0	48,1	38,7	29,5	17,5
5HME08S15	1,5	ESM80/315 HM..	1 x 1,83	4,44	88,9	89,5	87,7	80,2	65,5	52,8	40,5	24,4
5HME10S22	2,2	ESM80/322 HM..	1 x 2,54	5,87	111,1	111,8	109,5	105,3	95,0	77,9	61,6	40,4

** PUMP TYPE HME..S, HME..N Three-phases	MOTOR PN TYPE KW		e-SM SET * P1 380-460 V KW A		Q = DELIVERY							
					l/min 0	40,0	80,0	120,0	160,0	200,0	240,0	283,3
					m <sup>3</sup> /h 0	2,4	4,8	7,2	9,6	12,0	14,4	17,0
H = TOTAL HEAD IN METRES OF COLUMN OF WATER												
10HME01S07	0,75	ESM80/307 HM..	1 x 0,84	2,24	17,5	17,4	16,9	16,1	14,7	12,7	10,2	6,7
10HME02S11	1,1	ESM80/311 HM..	1 x 1,37	3,45	34,8	34,9	33,8	32,3	27,2	21,9	16,6	11,1
10HME03S15	1,5	ESM80/315 HM..	1 x 1,83	4,43	52,4	51,8	50,6	47,0	39,2	32,2	25,3	17,8
10HME04S22	2,2	ESM80/322 HM..	1 x 2,54	5,87	69,8	69,1	67,3	65,1	56,9	47,3	37,8	27,5

** PUMP TYPE HME..S, HME..N Three-phases	MOTOR PN TYPE KW		e-SM SET * P1 380-460 V KW A		Q = DELIVERY							
					l/min 0	70,0	140,0	210,0	280,0	350,0	420,0	483,3
					m <sup>3</sup> /h 0	4,2	8,4	12,6	16,8	21,0	25,2	29,0
H = TOTAL HEAD IN METRES OF COLUMN OF WATER												
15HME01S11	1,1	ESM80/311 HM..	1 x 0,84	3,45	20,9	20,5	19,7	18,8	16,4	12,7	8,8	5,2
15HME02S15	1,5	ESM80/315 HM..	1 x 1,85	4,47	42,7	41,8	35,9	29,8	24,2	18,2	11,3	5,1
15HME03S22	2,2	ESM80/322 HM..	1 x 2,5	5,80	64,0	64,1	50,5	40,6	31,9	23,4	15,4	10,0

Table refers to hydraulic performances with one pump running, max rpm, friction loss not included

g10\_1-15hmes-esmT-2p50-en\_a\_th

\* Maximum value in specified range: P1 = input power; I = input nominal current absorbed by set

\*\* For technical details see technical catalogue of single electric pump

## ELECTRIC PUMP THREE-PHASE TABLE OF ELECTRIC MOTOR DATA

In the range 3000-3600 rpm the nominal motor power is guaranteed. Above 3600 rpm it isn't possible work and the motor is automatically limited; below 3000 rpm it works partially load.

### e-SVE

P <sub>N</sub> kW	MOTOR TYPE	IEC SIZE*	Construction Design	SPEED (RPM)** min <sup>-1</sup>	INPUT CURRENT I (A) 208-240/380-460 V	DATA RELATED TO THE VOLTAGE OF 400V						IES
						I <sub>n</sub> A	cosφ	T <sub>n</sub> Nm	η %			
									4/4	3/4	2/4	
0,37	ESM90R/303 SVE	90R	V18/B14	3000	2,01-1,85/1,41-1,28	1,42	0,48	1,18	78,6	75,6	70,1	2
				3600	2,13-1,83/1,43-1,33	1,36		0,98	83,1	80,7	76,1	
0,55	ESM90R/305 SVE	90R		3000	2,81-2,57/1,89-1,69	1,88	0,52	1,75	81,1	79,3	75,5	2
				3600	2,90-2,52/1,90-1,73	1,80		1,46	85,4	83,8	80,6	
0,75	ESM90R/307 SVE	90R		3000	3,70-3,37/2,44-2,17	2,41	0,55	2,39	81,9	81,2	78,6	2
				3600	3,74-3,28/2,43-2,20	2,31		1,99	86,1	85,5	83,1	
1,10	ESM90R/311 SVE	90R		3000	5,12-4,73/3,41-3,01	3,35	0,57	3,50	82,8	81,3	77,7	2
				3600	5,15-4,69/3,45-3,06	3,32		2,92	83,5	81,6	77,6	
1,50	ESM90R/315 SVE	90R		3000	6,73-6,17/4,49-3,95	4,39	0,59	4,77	83,1	82,8	80,6	2
				3600	6,69-6,08/4,48-3,97	4,32		3,98	84,6	83,6	80,8	
2,20	ESM90R/322 SVE	90R		3000	- /6,03-5,32	5,81	0,62	7,00	87,6	87,4	85,9	2
				3600	- /5,93-5,24	5,74		5,84	88,9	88,2	86,3	

\* R = Reduced size of motor casing as compared to shaft extension and flange.

eSV\_Smart-mott\_en\_a\_te

\*\* The indicated rotational speed are representing the upper and lower limits of the rated power operational speed range.

### VME, e-HME

P <sub>N</sub> kW	MOTOR TYPE	IEC SIZE*	Construction Design	SPEED (RPM) * min <sup>-1</sup>	INPUT CURRENT I (A) 208-240/380-460 V	DATA RELATED TO THE VOLTAGE OF 400 V						IES
						I <sub>n</sub> A	cosφ	T <sub>n</sub> Nm	η %			
									4/4	3/4	2/4	
0,37	ESM80/303 HM..	80	SPECIAL	3000	2,01-1,85/1,41-1,28	1,42	0,48	1,18	78,6	75,6	70,1	2
				3600	2,13-1,83/1,43-1,33	1,36		0,98	83,1	80,7	76,1	
0,55	ESM80/305 HM..	80		3000	2,81-2,57/1,89-1,69	1,88	0,52	1,75	81,1	79,3	75,5	2
				3600	2,90-2,52/1,90-1,73	1,80		1,46	85,4	83,8	80,6	
0,75	ESM80/307 HM..	80		3000	3,70-3,37/2,44-2,17	2,41	0,55	2,39	81,9	81,2	78,6	2
				3600	3,74-3,28/2,43-2,20	2,31		1,99	86,1	85,5	83,1	
1,10	ESM80/311 HM..	80		3000	5,12-4,73/3,41-3,01	3,35	0,57	3,50	82,8	81,3	77,7	2
				3600	5,15-4,69/3,45-3,06	3,32		2,92	83,5	81,6	77,6	
1,50	ESM80/315 HM..	80		3000	6,73-6,17/4,49-3,95	4,39	0,59	4,77	83,1	82,8	80,6	2
				3600	6,69-6,08/4,48-3,97	4,32		3,98	84,6	83,6	80,8	
2,20	ESM80/322 HM..	80		3000	- /6,03-5,32	5,81	0,62	7,00	87,6	87,4	85,9	2
				3600	- /5,93-5,24	5,74		5,84	88,9	88,2	86,3	

\* The indicated rotational speed are representing the upper and lower limits of the rated power operational speed range.

eHM-eVM\_Smart-mott-en\_a\_te

## SMB20/..SVE BOOSTER SETS SERIES THREE-PHASE TABLE OF HYDRAULIC PERFORMANCE

** PUMP TYPE SVE Three-phases	MOTOR		SMB20 SET		Q = DELIVERY							
	P <sub>N</sub> kW	TYPE	* P <sub>1</sub> kW	* I 380-460 V A	l/min 0	13,3	26,7	40,0	53,3	66,7	80,0	93,3
					m <sup>3</sup> /h 0	0,8	1,6	2,4	3,2	4,0	4,8	5,6
H = TOTAL HEAD IN METRES OF COLUMN OF WATER												
1SVE05..003	0,37	ESM90R/303 SVE	2 x 0,49	2,90	44,7	45,0	45,2	44,6	41,5	34,9	28,0	20,8
1SVE08..005	0,55	ESM90R/305 SVE	2 x 0,69	3,80	71,5	72,0	72,3	71,2	62,4	52,1	41,2	29,7
1SVE11..007	0,75	ESM90R/307 SVE	2 x 0,91	4,80	98,3	99,1	99,3	97,7	85,0	70,9	56,0	40,1
1SVE15..011	1,1	ESM90R/311 SVE	2 x 1,37	6,90	134,1	135,1	135,5	133,8	123,6	104,0	83,3	61,4

** PUMP TYPE SVE Three-phases	MOTOR		SMB20 SET		Q = DELIVERY							
	P <sub>N</sub> kW	TYPE	* P <sub>1</sub> kW	* I 380-460 V A	l/min 0	26,7	53,3	80,0	106,7	133,3	160,0	173,3
					m <sup>3</sup> /h 0	1,6	3,2	4,8	6,4	8,0	9,6	10,4
H = TOTAL HEAD IN METRES OF COLUMN OF WATER												
3SVE03..003	0,37	ESM90R/303 SVE	2 x 0,49	2,94	33,4	33,8	33,6	30,7	24,9	19,5	14,0	10,9
3SVE05..005	0,55	ESM90R/305 SVE	2 x 0,7	3,84	55,7	56,2	55,8	46,3	37,1	28,4	19,4	14,4
3SVE07..007	0,75	ESM90R/307 SVE	2 x 0,93	4,86	77,9	78,7	77,2	63,3	50,6	38,6	26,0	18,7
3SVE09..011	1,1	ESM90R/311 SVE	2 x 1,37	6,90	100,2	101,0	100,5	88,8	72,5	56,4	39,9	31,2
3SVE11..015	1,5	ESM90R/315 SVE	2 x 1,82	8,84	122,5	123,3	122,5	117,9	98,4	77,9	57,2	46,4

** PUMP TYPE SVE Three-phases	MOTOR		SMB20 SET		Q = DELIVERY							
	P <sub>N</sub> kW	TYPE	* P <sub>1</sub> kW	* I 380-460 V A	l/min 0	46,7	93,3	140,0	186,7	233,3	280,0	333,3
					m <sup>3</sup> /h 0	2,8	5,6	8,4	11,2	14,0	16,8	20,0
H = TOTAL HEAD IN METRES OF COLUMN OF WATER												
5SVE02..003	0,37	ESM90R/303 SVE	2 x 0,5	2,96	22,4	22,2	21,8	20,0	16,5	13,3	10,2	6,5
5SVE03..005	0,55	ESM90R/305 SVE	2 x 0,69	3,84	33,5	33,3	32,7	29,8	24,5	19,8	15,2	9,5
5SVE04..007	0,75	ESM90R/307 SVE	2 x 0,92	4,84	44,7	44,4	43,5	40,5	33,4	27,0	20,8	13,3
5SVE06..011	1,1	ESM90R/311 SVE	2 x 1,38	6,92	67,1	66,6	65,3	59,5	49,0	39,6	30,3	19,1
5SVE08..015	1,5	ESM90R/315 SVE	2 x 1,83	8,86	88,8	89,2	87,6	82,7	68,4	55,3	42,7	28,0
5SVE12..022	2,2	ESM90R/322 SVE	2 x 2,55	11,76	133,2	133,7	131,6	121,6	100,4	81,0	62,2	40,3

** PUMP TYPE SVE Three-phases	MOTOR		SMB20 SET		Q = DELIVERY							
	P <sub>N</sub> kW	TYPE	* P <sub>1</sub> kW	* I 380-460 V A	l/min 0	80,0	160,0	240,0	320,0	400,0	480,0	566,7
					m <sup>3</sup> /h 0	4,8	9,6	14,4	19,2	24,0	28,8	34,0
H = TOTAL HEAD IN METRES OF COLUMN OF WATER												
10SVE01..005	0,55	ESM90R/305 SVE	2 x 0,69	3,80	17,3	17,3	16,9	16,2	13,6	10,4	7,1	3,3
10SVE02..007	0,75	ESM90R/307 SVE	2 x 0,94	4,92	24,2	23,9	23,1	21,7	19,3	14,6	9,7	3,6
10SVE02..011	1,1	ESM90R/311 SVE	2 x 1,37	6,90	34,8	34,5	33,7	32,3	27,7	22,4	17,1	11,0
10SVE03..015	1,5	ESM90R/315 SVE	2 x 1,83	8,86	52,7	52,2	51,0	46,1	38,1	30,8	23,5	15,1
10SVE04..022	2,2	ESM90R/322 SVE	2 x 2,54	11,72	70,3	69,7	68,1	65,8	57,8	47,5	37,4	25,9

** PUMP TYPE SVE Three-phases	MOTOR		SMB20 SET		Q = DELIVERY							
	P <sub>N</sub> kW	TYPE	* P <sub>1</sub> kW	* I 380-460 V A	l/min 0	140,0	280,0	420,0	560,0	700,0	840,0	966,7
					m <sup>3</sup> /h 0	8,4	16,8	25,2	33,6	42,0	50,4	58,0
H = TOTAL HEAD IN METRES OF COLUMN OF WATER												
15SVE01..007	0,75	ESM90R/307 SVE	2 x 0,92	4,96	14,2	13,9	13,3	12,3	9,8	6,4	2,8	0,0
15SVE01..011	1,1	ESM90R/311 SVE	2 x 1,33	6,90	20,5	20,1	19,4	18,4	14,8	10,9	7,0	3,2
15SVE02..015	1,5	ESM90R/315 SVE	2 x 1,76	8,68	29,6	29,1	28,3	26,8	22,2	16,4	10,1	3,8
15SVE02..022	2,2	ESM90R/322 SVE	2 x 2,54	11,74	42,7	42,0	41,1	39,7	33,4	26,8	20,1	13,5

** PUMP TYPE SVE Three-phases	MOTOR		SMB20 SET		Q = DELIVERY							
	P <sub>N</sub> kW	TYPE	* P <sub>1</sub> kW	* I 380-460 V A	l/min 0	140,0	280,0	420,0	560,0	700,0	840,0	1000,0
					m <sup>3</sup> /h 0	8,4	16,8	25,2	33,6	42,0	50,4	60,0
H = TOTAL HEAD IN METRES OF COLUMN OF WATER												
22SVE01..007	0,75	ESM90R/307 SVE	2 x 0,91	4,76	14,4	14,4	14,1	12,5	9,5	6,3	2,9	0,0
22SVE01..011	1,1	ESM90R/311 SVE	2 x 1,38	6,94	20,7	20,8	20,5	18,7	15,1	11,5	7,8	3,2
22SVE02..015	1,5	ESM90R/315 SVE	2 x 1,76	8,62	31,4	31,0	30,3	26,7	21,7	16,7	11,0	2,8
22SVE02..022	2,2	ESM90R/322 SVE	2 x 2,56	11,82	45,2	44,7	44,0	39,3	33,0	27,3	21,4	13,6

Table refers to hydraulic performances with two pumps running, max rpm, friction loss not included

g20\_1-22sve-esmT-2p50-en\_a\_th

\* Maximum value in specified range: P<sub>1</sub> = input power; I = input nominal current absorbed by set

\*\* For technical details see see technical catalogue of single electric pump

## SMB20/..VME BOOSTER SETS SERIES THREE-PHASE TABLE OF HYDRAULIC PERFORMANCE

** PUMP TYPE VME Three-phases	MOTOR		SMB20 SET		Q = DELIVERY							
	PN kW	TYPE	* P1 kW	* I 380-460 V A	l/min 0	13,3	26,7	40,0	53,3	66,7	80,0	100,0
					m <sup>3</sup> /h 0	0,8	1,6	2,4	3,2	4,0	4,8	6,0
H = TOTAL HEAD IN METRES OF COLUMN OF WATER												
1VME02P03T	0,37	ESM80/303 HM..	2 x 0,49	2,90	34,4	33,3	32,1	30,6	28,4	24,4	20,5	14,6
1VME04P05T	0,55	ESM80/305 HM..	2 x 0,69	3,84	57,5	55,3	53,1	50,4	46,7	39,4	32,1	21,9
1VME05P07T	0,75	ESM80/307 HM..	2 x 0,91	4,82	80,8	78,0	75,0	71,7	63,0	53,5	44,1	30,8
1VME06P11T	1,1	ESM80/311 HM..	2 x 1,37	6,88	99,8	96,3	92,8	88,5	83,2	76,1	65,4	47,9

** PUMP TYPE VME Three-phases	MOTOR		SMB20 SET		Q = DELIVERY							
	PN kW	TYPE	* P1 kW	* I 380-460 V A	l/min 0	26,7	53,3	80,0	106,7	133,3	160,0	173,3
					m <sup>3</sup> /h 0	1,6	3,2	4,8	6,4	8,0	9,6	10,4
H = TOTAL HEAD IN METRES OF COLUMN OF WATER												
3VME02P03T	0,37	ESM80/303 HM..	2 x 0,5	2,96	35,5	34,3	31,2	25,1	19,5	14,5	9,8	7,5
3VME03P05T	0,55	ESM80/305 HM..	2 x 0,7	3,84	53,2	51,3	47,1	37,9	29,8	22,7	16,1	12,4
3VME04P07T	0,75	ESM80/307 HM..	2 x 0,92	4,86	70,9	68,3	64,0	51,6	40,6	31,1	22,3	17,3
3VME05P11T	1,1	ESM80/311 HM..	2 x 1,37	6,90	88,6	85,5	82,4	74,2	59,4	46,5	34,9	28,8
3VME06P15T	1,5	ESM80/315 HM..	2 x 1,81	8,80	100,5	96,8	93,2	86,6	77,0	64,1	49,3	42,0

** PUMP TYPE VME Three-phases	MOTOR		SMB20 SET		Q = DELIVERY							
	PN kW	TYPE	* P1 kW	* I 380-460 V A	l/min 0	40,0	80,0	120,0	160,0	200,0	240,0	280,0
					m <sup>3</sup> /h 0	2,4	4,8	7,2	9,6	12,0	14,4	16,8
H = TOTAL HEAD IN METRES OF COLUMN OF WATER												
5VME02P05T	0,55	ESM80/305 HM..	2 x 0,69	3,82	36,3	34,8	33,4	29,1	23,5	18,7	14,1	8,9
5VME03P07T	0,75	ESM80/307 HM..	2 x 0,92	4,86	54,2	52,4	49,8	39,9	32,5	25,8	18,8	11,5
5VME04P11T	1,1	ESM80/311 HM..	2 x 1,37	6,90	72,3	69,9	66,3	57,8	47,4	38,2	28,6	18,6
5VME05P15T	1,5	ESM80/315 HM..	2 x 1,82	8,84	90,4	87,4	82,9	78,0	64,2	52,3	40,1	27,3
5VME06P22T	2,2	ESM80/322 HM..	2 x 2,33	10,88	99,6	96,1	90,9	85,3	78,6	69,2	55,6	37,2

** PUMP TYPE VME Three-phases	MOTOR		SMB20 SET		Q = DELIVERY							
	PN kW	TYPE	* P1 kW	* I 380-460 V A	l/min 0	80,0	160,0	240,0	320,0	400,0	480,0	566,7
					m <sup>3</sup> /h 0	4,8	9,6	14,4	19,2	24,0	28,8	34,0
H = TOTAL HEAD IN METRES OF COLUMN OF WATER												
10VME01P07T	0,75	ESM80/307 HM..	2 x 0,91	4,80	22,6	22,2	21,2	20,0	16,6	13,5	10,4	6,8
10VME02P11T	1,1	ESM80/311 HM..	2 x 1,38	6,94	38,0	37,2	35,4	30,7	24,7	19,2	13,4	6,7

Table refers to hydraulic performances with two pumps running, max rpm, friction loss not included

g20\_1-10vme-esmT-2p50-en\_a\_th

\* Maximum value in specified range: P1 = input power; I = input nominal current absorbed by set

\*\* For technical details see technical catalogue of single electric pump

## SMB20/..HME BOOSTER SETS SERIES THREE-PHASE TABLE OF HYDRAULIC PERFORMANCE

** PUMP TYPE HME..S, HME..N Three-phases	MOTOR PN TYPE KW		SMB20 SET * P1 380-460 V KW A		Q = DELIVERY							
					l/min 0	13,3	26,7	40,0	53,3	66,7	80,0	93,3
					m <sup>3</sup> /h 0	0,8	1,6	2,4	3,2	4,0	4,8	5,6
H = TOTAL HEAD IN METRES OF COLUMN OF WATER												
1HME05S03	0,55	ESM80/305 HM..	2 x 0,49	2,92	44,7	44,8	44,9	44,1	39,2	32,5	25,7	19,0
1HME08S05	0,55	ESM80/305 HM..	2 x 0,69	3,80	71,6	71,5	71,7	70,4	60,3	50,0	39,6	29,0
1HME11S07	0,75	ESM80/307 HM..	2 x 0,91	4,82	98,5	98,5	98,8	94,3	80,7	66,8	52,9	38,6
1HME15S11	1,1	ESM80/311 HM..	2 x 1,37	6,90	134,0	134,4	134,6	132,3	119,5	99,6	79,6	59,6
1HME17S15	1,5	ESM80/315 HM..	2 x 1,81	8,78	151,8	152,2	152,7	149,6	141,6	128,6	110,7	87,1

** PUMP TYPE HME..S, HME..N Three-phases	MOTOR PN TYPE KW		SMB20 SET * P1 380-460 V KW A		Q = DELIVERY							
					l/min 0	26,7	53,3	80,0	106,7	133,3	160,0	173,3
					m <sup>3</sup> /h 0	1,6	3,2	4,8	6,4	8,0	9,6	10,4
H = TOTAL HEAD IN METRES OF COLUMN OF WATER												
3HME03S03	0,37	ESM80/303 HM..	2 x 0,49	2,94	33,3	33,9	33,4	31,5	25,6	20,1	14,5	11,8
3HME05S05	0,55	ESM80/305 HM..	2 x 0,7	3,84	55,5	56,5	55,7	47,5	38,2	29,4	20,4	16,0
3HME07S07	0,75	ESM80/307 HM..	2 x 0,92	4,86	77,6	79,1	78,1	64,9	52,1	39,8	27,5	21,3
3HME09S11	1,1	ESM80/311 HM..	2 x 1,37	6,90	99,8	101,8	100,3	93,7	76,1	59,6	43,0	34,7
3HME12S15	1,5	ESM80/315 HM..	2 x 1,82	8,84	133,1	135,9	133,6	127,3	103,6	81,5	59,2	48,1
3HME14S22	2,2	ESM80/322 HM..	2 x 2,53	11,68	155,4	158,3	156,1	149,5	139,0	121,7	93,9	79,8

** PUMP TYPE HME..S, HME..N Three-phases	MOTOR PN TYPE KW		SMB20 SET * P1 380-460 V KW A		Q = DELIVERY							
					l/min 0	46,7	93,3	140,0	186,7	233,3	280,0	340,0
					m <sup>3</sup> /h 0	2,8	5,6	8,4	11,2	14,0	16,8	20,4
H = TOTAL HEAD IN METRES OF COLUMN OF WATER												
5HME02S03	0,37	ESM80/303 HM..	2 x 0,5	2,96	22,2	22,4	21,9	19,8	16,2	13,0	9,9	6,0
5HME03S05	0,55	ESM80/305 HM..	2 x 0,7	3,84	33,3	33,6	32,9	29,5	24,1	19,3	14,7	8,8
5HME04S07	0,75	ESM80/307 HM..	2 x 0,92	4,84	44,4	44,7	43,8	40,1	32,8	26,4	20,2	12,2
5HME06S11	1,1	ESM80/311 HM..	2 x 1,38	6,92	66,7	67,2	65,8	59,0	48,1	38,7	29,5	17,5
5HME08S15	1,5	ESM80/315 HM..	2 x 1,83	8,88	88,9	89,5	87,7	80,2	65,5	52,8	40,5	24,4
5HME10S22	2,2	ESM80/322 HM..	2 x 2,54	11,74	111,1	111,8	109,5	105,3	95,0	77,9	61,6	40,4

** PUMP TYPE HME..S, HME..N Three-phases	MOTOR PN TYPE KW		SMB20 SET * P1 380-460 V KW A		Q = DELIVERY							
					l/min 0	80,0	160,0	240,0	320,0	400,0	480,0	566,7
					m <sup>3</sup> /h 0	4,8	9,6	14,4	19,2	24,0	28,8	34,0
H = TOTAL HEAD IN METRES OF COLUMN OF WATER												
10HME01S07	0,75	ESM80/307 HM..	2 x 0,84	4,48	17,5	17,4	16,9	16,1	14,7	12,7	10,2	6,7
10HME02S11	1,1	ESM80/311 HM..	2 x 1,37	6,90	34,8	34,9	33,8	32,3	27,2	21,9	16,6	11,1
10HME03S15	1,5	ESM80/315 HM..	2 x 1,83	8,86	52,4	51,8	50,6	47,0	39,2	32,2	25,3	17,8
10HME04S22	2,2	ESM80/322 HM..	2 x 2,54	11,74	69,8	69,1	67,3	65,1	56,9	47,3	37,8	27,5

** PUMP TYPE HME..S, HME..N Three-phases	MOTOR PN TYPE KW		SMB20 SET * P1 380-460 V KW A		Q = DELIVERY							
					l/min 0	140,0	280,0	420,0	560,0	700,0	840,0	966,7
					m <sup>3</sup> /h 0	8,4	16,8	25,2	33,6	42,0	50,4	58,0
H = TOTAL HEAD IN METRES OF COLUMN OF WATER												
15HME01S11	1,1	ESM80/311 HM..	2 x 0,84	6,90	20,9	20,5	19,7	18,8	16,4	12,7	8,8	5,2
15HME02S15	1,5	ESM80/315 HM..	2 x 1,85	8,94	42,7	41,8	35,9	29,8	24,2	18,2	11,3	5,1
15HME03S22	2,2	ESM80/322 HM..	2 x 2,5	11,60	64,0	64,1	50,5	40,6	31,9	23,4	15,4	10,0

Table refers to hydraulic performances with two pumps running, max rpm, friction loss not included

g20\_1-15hmes-esmT-2p50-en\_a\_th

\* Maximum value in specified range: P1 = input power; I = input nominal current absorbed by set

\*\* For technical details see technical catalogue of single electric pump

## SMB30/..SVE BOOSTER SETS SERIES

### THREE-PHASE TABLE OF HYDRAULIC PERFORMANCE

** PUMP TYPE SVE Three-phases	MOTOR		SMB30 SET		Q = DELIVERY							
	P <sub>N</sub> kW	TYPE	* P <sub>1</sub> kW	* I 380-460 V A	l/min 0	20,0	40,0	60,0	80,0	100,0	120,0	140,0
					m <sup>3</sup> /h 0	1,2	2,4	3,6	4,8	6,0	7,2	8,4
H = TOTAL HEAD IN METRES OF COLUMN OF WATER												
1SVE05..003	0,37	ESM90R/303 SVE	3 x 0,49	4,35	44,7	45,0	45,2	44,6	41,5	34,9	28,0	20,8
1SVE08..005	0,55	ESM90R/305 SVE	3 x 0,69	5,70	71,5	72,0	72,3	71,2	62,4	52,1	41,2	29,7
1SVE11..007	0,75	ESM90R/307 SVE	3 x 0,91	7,20	98,3	99,1	99,3	97,7	85,0	70,9	56,0	40,1
1SVE15..011	1,1	ESM90R/311 SVE	3 x 1,37	10,35	134,1	135,1	135,5	133,8	123,6	104,0	83,3	61,4

** PUMP TYPE SVE Three-phases	MOTOR		SMB30 SET		Q = DELIVERY							
	P <sub>N</sub> kW	TYPE	* P <sub>1</sub> kW	* I 380-460 V A	l/min 0	40,0	80,0	120,0	160,0	200,0	240,0	260,0
					m <sup>3</sup> /h 0	2,4	4,8	7,2	9,6	12,0	14,4	15,6
H = TOTAL HEAD IN METRES OF COLUMN OF WATER												
3SVE03..003	0,37	ESM90R/303 SVE	3 x 0,49	4,41	33,4	33,8	33,6	30,7	24,9	19,5	14,0	10,9
3SVE05..005	0,55	ESM90R/305 SVE	3 x 0,7	5,76	55,7	56,2	55,8	46,3	37,1	28,4	19,4	14,4
3SVE07..007	0,75	ESM90R/307 SVE	3 x 0,93	7,29	77,9	78,7	77,2	63,3	50,6	38,6	26,0	18,7
3SVE09..011	1,1	ESM90R/311 SVE	3 x 1,37	10,35	100,2	101,0	100,5	88,8	72,5	56,4	39,9	31,2
3SVE11..015	1,5	ESM90R/315 SVE	3 x 1,82	13,26	122,5	123,3	122,5	117,9	98,4	77,9	57,2	46,4

** PUMP TYPE SVE Three-phases	MOTOR		SMB30 SET		Q = DELIVERY							
	P <sub>N</sub> kW	TYPE	* P <sub>1</sub> kW	* I 380-460 V A	l/min 0	70,0	140,0	210,0	280,0	350,0	420,0	500,0
					m <sup>3</sup> /h 0	4,2	8,4	12,6	16,8	21,0	25,2	30,0
H = TOTAL HEAD IN METRES OF COLUMN OF WATER												
5SVE02..003	0,37	ESM90R/303 SVE	3 x 0,5	4,44	22,4	22,2	21,8	20,0	16,5	13,3	10,2	6,5
5SVE03..005	0,55	ESM90R/305 SVE	3 x 0,69	5,76	33,5	33,3	32,7	29,8	24,5	19,8	15,2	9,5
5SVE04..007	0,75	ESM90R/307 SVE	3 x 0,92	7,26	44,7	44,4	43,5	40,5	33,4	27,0	20,8	13,3
5SVE06..011	1,1	ESM90R/311 SVE	3 x 1,38	10,38	67,1	66,6	65,3	59,5	49,0	39,6	30,3	19,1
5SVE08..015	1,5	ESM90R/315 SVE	3 x 1,83	13,29	88,8	89,2	87,6	82,7	68,4	55,3	42,7	28,0
5SVE12..022	2,2	ESM90R/322 SVE	3 x 2,55	17,64	133,2	133,7	131,6	121,6	100,4	81,0	62,2	40,3

** PUMP TYPE SVE Three-phases	MOTOR		SMB30 SET		Q = DELIVERY							
	P <sub>N</sub> kW	TYPE	* P <sub>1</sub> kW	* I 380-460 V A	l/min 0	120,0	240,0	360,0	480,0	600,0	720,0	850,0
					m <sup>3</sup> /h 0	7,2	14,4	21,6	28,8	36,0	43,2	51,0
H = TOTAL HEAD IN METRES OF COLUMN OF WATER												
10SVE01..005	0,55	ESM90R/305 SVE	3 x 0,69	5,70	17,3	17,3	16,9	16,2	13,6	10,4	7,1	3,3
10SVE02..007	0,75	ESM90R/307 SVE	3 x 0,94	7,38	24,2	23,9	23,1	21,7	19,3	14,6	9,7	3,6
10SVE02..011	1,1	ESM90R/311 SVE	3 x 1,37	10,35	34,8	34,5	33,7	32,3	27,7	22,4	17,1	11,0
10SVE03..015	1,5	ESM90R/315 SVE	3 x 1,83	13,29	52,7	52,2	51,0	46,1	38,1	30,8	23,5	15,1
10SVE04..022	2,2	ESM90R/322 SVE	3 x 2,54	17,58	70,3	69,7	68,1	65,8	57,8	47,5	37,4	25,9

** PUMP TYPE SVE Three-phases	MOTOR		SMB30 SET		Q = DELIVERY							
	P <sub>N</sub> kW	TYPE	* P <sub>1</sub> kW	* I 380-460 V A	l/min 0	210,0	420,0	630,0	840,0	1050,0	1260,0	1450,0
					m <sup>3</sup> /h 0	12,6	25,2	37,8	50,4	63,0	75,6	87,0
H = TOTAL HEAD IN METRES OF COLUMN OF WATER												
15SVE01..007	0,75	ESM90R/307 SVE	3 x 0,92	7,44	14,2	13,9	13,3	12,3	9,8	6,4	2,8	0,0
15SVE01..011	1,1	ESM90R/311 SVE	3 x 1,33	10,35	20,5	20,1	19,4	18,4	14,8	10,9	7,0	3,2
15SVE02..015	1,5	ESM90R/315 SVE	3 x 1,76	13,02	29,6	29,1	28,3	26,8	22,2	16,4	10,1	3,8
15SVE02..022	2,2	ESM90R/322 SVE	3 x 2,54	17,61	42,7	42,0	41,1	39,7	33,4	26,8	20,1	13,5

** PUMP TYPE SVE Three-phases	MOTOR		SMB30 SET		Q = DELIVERY							
	P <sub>N</sub> kW	TYPE	* P <sub>1</sub> kW	* I 380-460 V A	l/min 0	210,0	420,0	630,0	840,0	1050,0	1260,0	1500,0
					m <sup>3</sup> /h 0	12,6	25,2	37,8	50,4	63,0	75,6	90,0
H = TOTAL HEAD IN METRES OF COLUMN OF WATER												
22SVE01..007	0,75	ESM90R/307 SVE	3 x 0,91	7,14	14,4	14,4	14,1	12,5	9,5	6,3	2,9	0,0
22SVE01..011	1,1	ESM90R/311 SVE	3 x 1,38	10,41	20,7	20,8	20,5	18,7	15,1	11,5	7,8	3,2
22SVE02..015	1,5	ESM90R/315 SVE	3 x 1,76	12,93	31,4	31,0	30,3	26,7	21,7	16,7	11,0	2,8
22SVE02..022	2,2	ESM90R/322 SVE	3 x 2,56	17,73	45,2	44,7	44,0	39,3	33,0	27,3	21,4	13,6

Table refers to hydraulic performances with three pumps running, max rpm, friction loss not included

g30\_1-22sve-esmT-2p50-en\_a\_th

\* Maximum value in specified range: P<sub>1</sub> = input power; I = input nominal current absorbed by set

\*\* For technical details see see technical catalogue of single electric pump

## SMB30/..VME BOOSTER SETS SERIES THREE-PHASE TABLE OF HYDRAULIC PERFORMANCE

** PUMP TYPE VME Three-phases	MOTOR		SMB30 SET		Q = DELIVERY							
	PN kW	TYPE	* P1 kW	* I 380-460 V A	l/min 0	20,0	40,0	60,0	80,0	100,0	120,0	150,0
					m <sup>3</sup> /h 0	1,2	2,4	3,6	4,8	6,0	7,2	9,0
H = TOTAL HEAD IN METRES OF COLUMN OF WATER												
1VME02P03T	0,37	ESM80/303 HM..	3 x 0,49	4,35	34,4	33,3	32,1	30,6	28,4	24,4	20,5	14,6
1VME04P05T	0,55	ESM80/305 HM..	3 x 0,69	5,76	57,5	55,3	53,1	50,4	46,7	39,4	32,1	21,9
1VME05P07T	0,75	ESM80/307 HM..	3 x 0,91	7,23	80,8	78,0	75,0	71,7	63,0	53,5	44,1	30,8
1VME06P11T	1,1	ESM80/311 HM..	3 x 1,37	10,32	99,8	96,3	92,8	88,5	83,2	76,1	65,4	47,9

** PUMP TYPE VME Three-phases	MOTOR		SMB30 SET		Q = DELIVERY							
	PN kW	TYPE	* P1 kW	* I 380-460 V A	l/min 0	40,0	80,0	120,0	160,0	200,0	240,0	260,0
					m <sup>3</sup> /h 0	2,4	4,8	7,2	9,6	12,0	14,4	15,6
H = TOTAL HEAD IN METRES OF COLUMN OF WATER												
3VME02P03T	0,37	ESM80/303 HM..	3 x 0,5	4,44	35,5	34,3	31,2	25,1	19,5	14,5	9,8	7,5
3VME03P05T	0,55	ESM80/305 HM..	3 x 0,7	5,76	53,2	51,3	47,1	37,9	29,8	22,7	16,1	12,4
3VME04P07T	0,75	ESM80/307 HM..	3 x 0,92	7,29	70,9	68,3	64,0	51,6	40,6	31,1	22,3	17,3
3VME05P11T	1,1	ESM80/311 HM..	3 x 1,37	10,35	88,6	85,5	82,4	74,2	59,4	46,5	34,9	28,8
3VME06P15T	1,5	ESM80/315 HM..	3 x 1,81	13,20	100,5	96,8	93,2	86,6	77,0	64,1	49,3	42,0

** PUMP TYPE VME Three-phases	MOTOR		SMB30 SET		Q = DELIVERY							
	PN kW	TYPE	* P1 kW	* I 380-460 V A	l/min 0	60,0	120,0	180,0	240,0	300,0	360,0	420,0
					m <sup>3</sup> /h 0	3,6	7,2	10,8	14,4	18,0	21,6	25,2
H = TOTAL HEAD IN METRES OF COLUMN OF WATER												
5VME02P05T	0,55	ESM80/305 HM..	3 x 0,69	5,73	36,3	34,8	33,4	29,1	23,5	18,7	14,1	8,9
5VME03P07T	0,75	ESM80/307 HM..	3 x 0,92	7,29	54,2	52,4	49,8	39,9	32,5	25,8	18,8	11,5
5VME04P11T	1,1	ESM80/311 HM..	3 x 1,37	10,35	72,3	69,9	66,3	57,8	47,4	38,2	28,6	18,6
5VME05P15T	1,5	ESM80/315 HM..	3 x 1,82	13,26	90,4	87,4	82,9	78,0	64,2	52,3	40,1	27,3
5VME06P22T	2,2	ESM80/322 HM..	3 x 2,33	16,32	99,6	96,1	90,9	85,3	78,6	69,2	55,6	37,2

** PUMP TYPE VME Three-phases	MOTOR		SMB30 SET		Q = DELIVERY							
	PN kW	TYPE	* P1 kW	* I 380-460 V A	l/min 0	120,0	240,0	360,0	480,0	600,0	720,0	850,0
					m <sup>3</sup> /h 0	7,2	14,4	21,6	28,8	36,0	43,2	51,0
H = TOTAL HEAD IN METRES OF COLUMN OF WATER												
10VME01P07T	0,75	ESM80/307 HM..	3 x 0,91	7,20	22,6	22,2	21,2	20,0	16,6	13,5	10,4	6,8
10VME02P11T	1,1	ESM80/311 HM..	3 x 1,38	10,41	38,0	37,2	35,4	30,7	24,7	19,2	13,4	6,7

Table refers to hydraulic performances with three pumps running, max rpm, friction loss not included

g30\_1-10vme-esmT-2p50-en\_a\_th

\* Maximum value in specified range: P1 = input power; I = input nominal current absorbed by set

\*\* For technical details see technical catalogue of single electric pump

## SMB30/..HME BOOSTER SETS SERIES THREE-PHASE TABLE OF HYDRAULIC PERFORMANCE

** PUMP TYPE HME..S, HME..N Three-phases	MOTOR PN TYPE kW		SMB30 SET * P1 380-460 V kW A		Q = DELIVERY							
					l/min 0	20,0	40,0	60,0	80,0	100,0	120,0	140,0
					m <sup>3</sup> /h 0	1,2	2,4	3,6	4,8	6,0	7,2	8,4
H = TOTAL HEAD IN METRES OF COLUMN OF WATER												
1HME05S03	0,55	ESM80/305 HM..	3 x 0,49	4,38	44,7	44,8	44,9	44,1	39,2	32,5	25,7	19,0
1HME08S05	0,55	ESM80/305 HM..	3 x 0,69	5,70	71,6	71,5	71,7	70,4	60,3	50,0	39,6	29,0
1HME11S07	0,75	ESM80/307 HM..	3 x 0,91	7,23	98,5	98,5	98,8	94,3	80,7	66,8	52,9	38,6
1HME15S11	1,1	ESM80/311 HM..	3 x 1,37	10,35	134,0	134,4	134,6	132,3	119,5	99,6	79,6	59,6
1HME17S15	1,5	ESM80/315 HM..	3 x 1,81	13,17	151,8	152,2	152,7	149,6	141,6	128,6	110,7	87,1

** PUMP TYPE HME..S, HME..N Three-phases	MOTOR PN TYPE kW		SMB30 SET * P1 380-460 V kW A		Q = DELIVERY							
					l/min 0	40,0	80,0	120,0	160,0	200,0	240,0	260,0
					m <sup>3</sup> /h 0	2,4	4,8	7,2	9,6	12,0	14,4	15,6
H = TOTAL HEAD IN METRES OF COLUMN OF WATER												
3HME03S03	0,37	ESM80/303 HM..	3 x 0,49	4,41	33,3	33,9	33,4	31,5	25,6	20,1	14,5	11,8
3HME05S05	0,55	ESM80/305 HM..	3 x 0,7	5,76	55,5	56,5	55,7	47,5	38,2	29,4	20,4	16,0
3HME07S07	0,75	ESM80/307 HM..	3 x 0,92	7,29	77,6	79,1	78,1	64,9	52,1	39,8	27,5	21,3
3HME09S11	1,1	ESM80/311 HM..	3 x 1,37	10,35	99,8	101,8	100,3	93,7	76,1	59,6	43,0	34,7
3HME12S15	1,5	ESM80/315 HM..	3 x 1,82	13,26	133,1	135,9	133,6	127,3	103,6	81,5	59,2	48,1
3HME14S22	2,2	ESM80/322 HM..	3 x 2,53	17,52	155,4	158,3	156,1	149,5	139,0	121,7	93,9	79,8

** PUMP TYPE HME..S, HME..N Three-phases	MOTOR PN TYPE kW		SMB30 SET * P1 380-460 V kW A		Q = DELIVERY							
					l/min 0	70,0	140,0	210,0	280,0	350,0	420,0	510,0
					m <sup>3</sup> /h 0	4,2	8,4	12,6	16,8	21,0	25,2	30,6
H = TOTAL HEAD IN METRES OF COLUMN OF WATER												
5HME02S03	0,37	ESM80/303 HM..	3 x 0,5	4,44	22,2	22,4	21,9	19,8	16,2	13,0	9,9	6,0
5HME03S05	0,55	ESM80/305 HM..	3 x 0,7	5,76	33,3	33,6	32,9	29,5	24,1	19,3	14,7	8,8
5HME04S07	0,75	ESM80/307 HM..	3 x 0,92	7,26	44,4	44,7	43,8	40,1	32,8	26,4	20,2	12,2
5HME06S11	1,1	ESM80/311 HM..	3 x 1,38	10,38	66,7	67,2	65,8	59,0	48,1	38,7	29,5	17,5
5HME08S15	1,5	ESM80/315 HM..	3 x 1,83	13,32	88,9	89,5	87,7	80,2	65,5	52,8	40,5	24,4
5HME10S22	2,2	ESM80/322 HM..	3 x 2,54	17,61	111,1	111,8	109,5	105,3	95,0	77,9	61,6	40,4

** PUMP TYPE HME..S, HME..N Three-phases	MOTOR PN TYPE kW		SMB30 SET * P1 380-460 V kW A		Q = DELIVERY							
					l/min 0	120,0	240,0	360,0	480,0	600,0	720,0	850,0
					m <sup>3</sup> /h 0	7,2	14,4	21,6	28,8	36,0	43,2	51,0
H = TOTAL HEAD IN METRES OF COLUMN OF WATER												
10HME01S07	0,75	ESM80/307 HM..	3 x 0,84	6,72	17,5	17,4	16,9	16,1	14,7	12,7	10,2	6,7
10HME02S11	1,1	ESM80/311 HM..	3 x 1,37	10,35	34,8	34,9	33,8	32,3	27,2	21,9	16,6	11,1
10HME03S15	1,5	ESM80/315 HM..	3 x 1,83	13,29	52,4	51,8	50,6	47,0	39,2	32,2	25,3	17,8
10HME04S22	2,2	ESM80/322 HM..	3 x 2,54	17,61	69,8	69,1	67,3	65,1	56,9	47,3	37,8	27,5

** PUMP TYPE HME..S, HME..N Three-phases	MOTOR PN TYPE kW		SMB30 SET * P1 380-460 V kW A		Q = DELIVERY							
					l/min 0	210,0	420,0	630,0	840,0	1050,0	1260,0	1450,0
					m <sup>3</sup> /h 0	12,6	25,2	37,8	50,4	63,0	75,6	87,0
H = TOTAL HEAD IN METRES OF COLUMN OF WATER												
15HME01S11	1,1	ESM80/311 HM..	3 x 0,84	10,35	20,9	20,5	19,7	18,8	16,4	12,7	8,8	5,2
15HME02S15	1,5	ESM80/315 HM..	3 x 1,85	13,41	42,7	41,8	35,9	29,8	24,2	18,2	11,3	5,1
15HME03S22	2,2	ESM80/322 HM..	3 x 2,5	17,40	64,0	64,1	50,5	40,6	31,9	23,4	15,4	10,0

Table refers to hydraulic performances with three pumps running, max rpm, friction loss not included

g30\_1-15hmes-esmT-2p50-en\_a\_th

\* Maximum value in specified range: P1 = input power; I = input nominal current absorbed by set

\*\* For technical details see technical catalogue of single electric pump

## Booster sets

### MARKET SECTORS

RESIDENTIAL, COMMERCIAL, INDUSTRIAL

## SMB10 Series

### APPLICATIONS

Water supply and pressure boosting in:

- apartments, villas, condominiums and residential buildings
- hotels, restaurants, spas
- various industrial applications

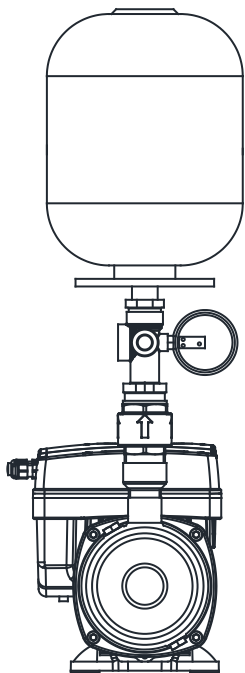

### SPECIFICATIONS

- **e-SVE** vertical axis electric pump.
- **e-HME..S** horizontal axis electric pump.
- **Flow rate:** up to 30 m<sup>3</sup>/h.
- **Head:** up to 158 m
- **Maximum operating pressure:** max 16 bar.
- **Electric panel supply voltage:**  
Standard version:
  - single-phase 1 x 230V ± 10% (SMB../M2).
  - three-phase 3 x 400V ± 10% (SMB../T4).
 Special version:
  - three-phase 3 x 230V ± 10% (SMB../T3).
- **Frequency:** 50Hz.
- **Protection class IP55 for:**
  - electrical pump motor
  - e-SM drive frequency converter
- **Maximum electric pump power:** 2,2 kW.
- **Progressive motor start.**
- **Maximum pumped liquid temperature:**
  - up to 80 °C for SMB../SVE
  - up to 80 °C for SMB../HME..S

**SMB series booster sets with e-SV Smart and e-HM Smart series pumps are certified for use with drinking water.**

## SET OF 1 PUMP SVE..F SERIES SINGLE-PHASE POWER SUPPLY (SMB10.../M2)

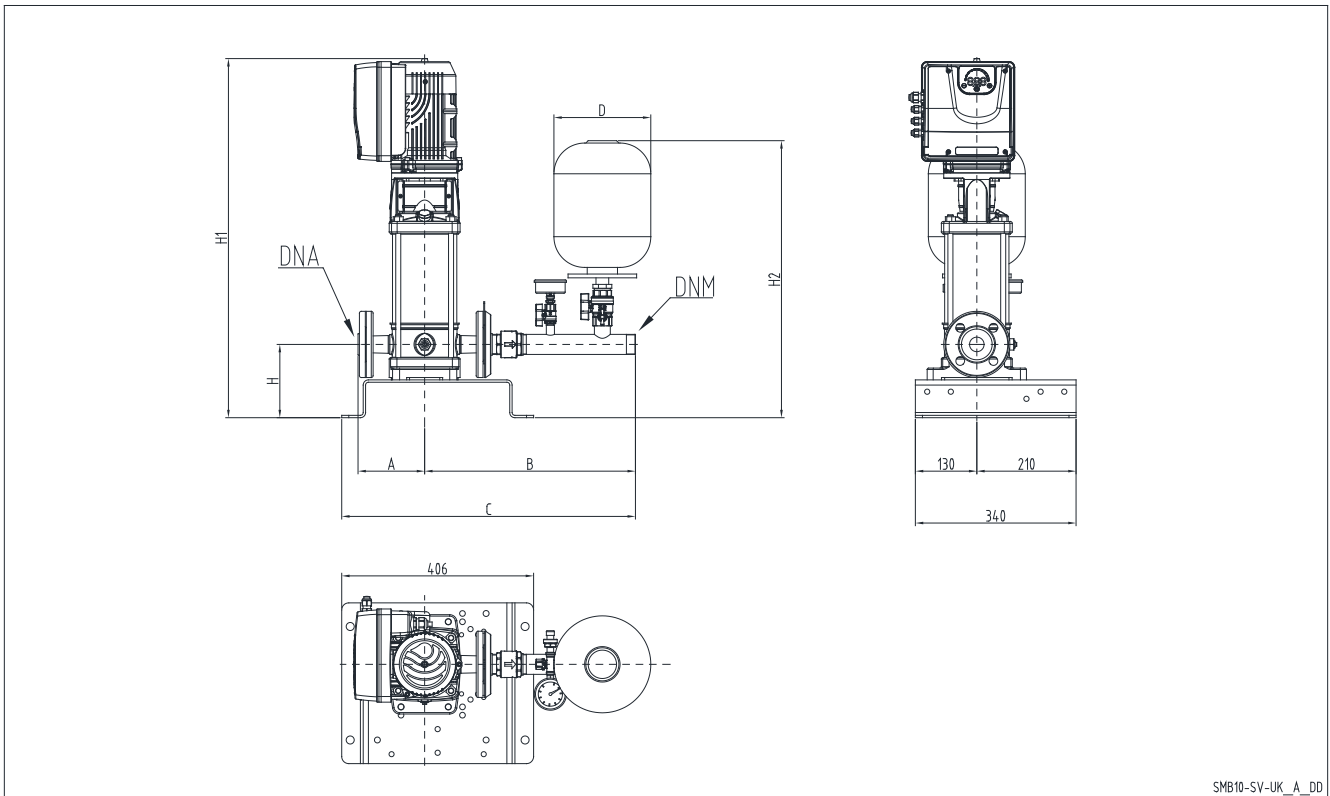

SMB10-SV-UK\_A\_DD

SMB 10	DNA	DNM	A	B	C	H	H1	H2
1SVE05F003	Rp1"	R1"	144	436	611	155	660	568
1SVE08F005	Rp1"	R1"	144	436	611	155	720	568
1SVE11F007	Rp1"	R1"	144	436	611	155	780	568
1SVE15F011	Rp1"	R1"	144	436	611	155	860	568
3SVE03F003	Rp1"	R1"	144	436	611	155	620	568
3SVE05F005	Rp1"	R1"	144	436	611	155	660	568
3SVE07F007	Rp1"	R1"	144	436	611	155	700	568
3SVE09F011	Rp1"	R1"	144	436	611	155	740	568
3SVE11F015	Rp1"	R1"	144	436	611	155	780	568
5SVE02F003	Rp1"1/4	R1"1/4	144	446	621	155	610	586
5SVE03F005	Rp1"1/4	R1"1/4	144	446	621	155	635	586
5SVE04F007	Rp1"1/4	R1"1/4	144	446	621	155	660	586
5SVE06F011	Rp1"1/4	R1"1/4	144	446	621	155	710	586
5SVE08F015	Rp1"1/4	R1"1/4	144	446	621	155	760	586
10SVE01F005	Rp1"1/2	R1"1/2	162	455	630	160	689	594
10SVE02F007	Rp1"1/2	R1"1/2	162	455	630	160	689	594
10SVE02F011	Rp1"1/2	R1"1/2	162	455	630	160	689	594
10SVE03F015	Rp1"1/2	R1"1/2	162	455	630	160	721	594
15SVE01F007	Rp2"	R2"	177	534	709	170	741	743
15SVE01F011	Rp2"	R2"	177	534	709	170	741	743
15SVE02F015	Rp2"	R2"	177	534	709	170	741	743
22SVE01F007	Rp2"	R2"	177	534	709	170	741	743
22SVE01F011	Rp2"	R2"	177	534	709	170	741	743
22SVE02F015	Rp2"	R2"	177	534	709	170	741	743

smb10-uk-sv-mono\_a\_td

### SET OF 1 PUMP SVE..F SERIES THREE-PHASE POWER SUPPLY (SMB10.../T3-T4)

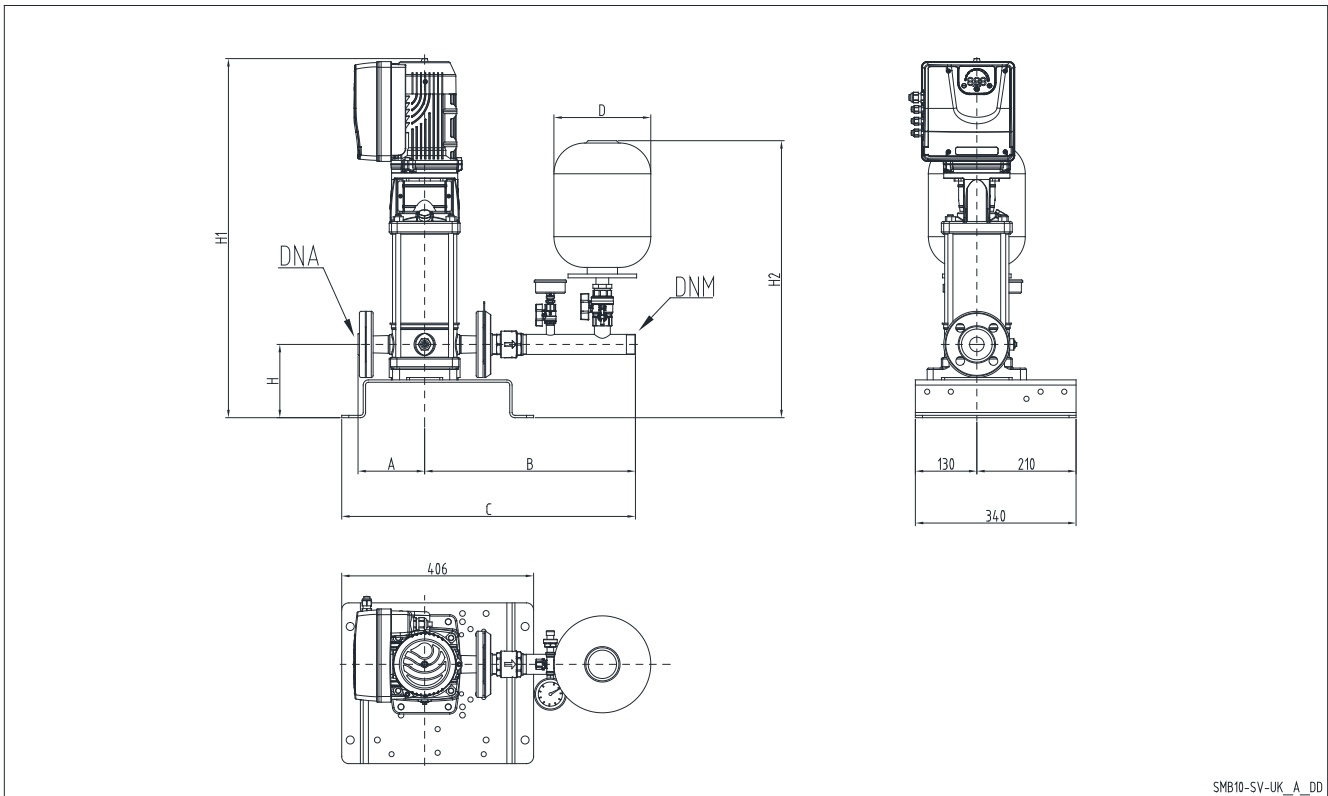

SMB10-SV-UK\_A\_DD

SMB 10	DNA	DNM	A	B	C	H	H1	H2
1SVE05F003	Rp1"	R1"	144	436	611	155	660	568
1SVE08F005	Rp1"	R1"	144	436	611	155	720	568
1SVE11F007	Rp1"	R1"	144	436	611	155	780	568
1SVE15F011	Rp1"	R1"	144	436	611	155	860	568
3SVE03F003	Rp1"	R1"	144	436	611	155	620	568
3SVE05F005	Rp1"	R1"	144	436	611	155	660	568
3SVE07F007	Rp1"	R1"	144	436	611	155	700	568
3SVE09F011	Rp1"	R1"	144	436	611	155	740	568
3SVE11F015	Rp1"	R1"	144	436	611	155	780	568
5SVE02F003	Rp1"1/4	R1"1/4	144	446	621	155	610	586
5SVE03F005	Rp1"1/4	R1"1/4	144	446	621	155	635	586
5SVE04F007	Rp1"1/4	R1"1/4	144	446	621	155	660	586
5SVE06F011	Rp1"1/4	R1"1/4	144	446	621	155	710	586
5SVE08F015	Rp1"1/4	R1"1/4	144	446	621	155	760	586
5SVE12F022	Rp1"1/4	R1"1/4	144	446	621	155	860	586
10SVE01F005	Rp1"1/2	R1"1/2	162	455	630	160	689	594
10SVE02F007	Rp1"1/2	R1"1/2	162	455	630	160	689	594
10SVE02F011	Rp1"1/2	R1"1/2	162	455	630	160	689	594
10SVE03F015	Rp1"1/2	R1"1/2	162	455	630	160	721	594
10SVE04F022	Rp1"1/2	R1"1/2	162	455	630	160	753	594
15SVE01F007	Rp2"	R2"	177	534	709	170	741	743
15SVE01F011	Rp2"	R2"	177	534	709	170	741	743
15SVE02F015	Rp2"	R2"	177	534	709	170	741	743
15SVE02F022	Rp2"	R2"	177	534	709	170	741	743
22SVE01F007	Rp2"	R2"	177	534	709	170	741	743
22SVE01F011	Rp2"	R2"	177	534	709	170	741	743
22SVE02F015	Rp2"	R2"	177	534	709	170	741	743
22SVE02F022	Rp2"	R2"	177	534	709	170	741	743

smb10-uk-sv-tri\_a\_td

## SET OF 1 PUMP HME..S SERIES THREE-PHASE POWER SUPPLY (SMB10.../T3-T4)

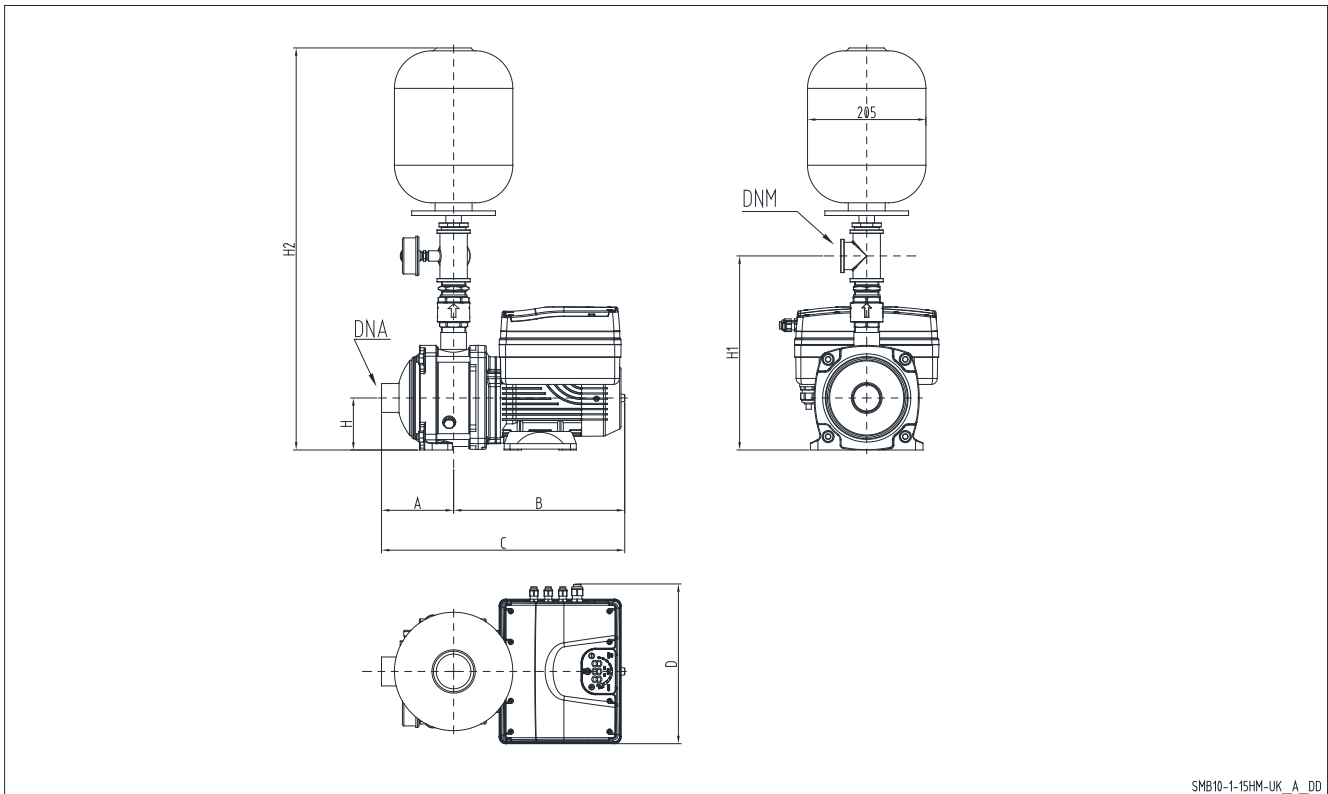

SMB10-1-15HM-UK\_A\_DD

SMB 20	DNA	DNM	A	B	C	D	H	H1	H2
1HME05	Rp 1"	Rp 1"	127	287	414	277	90	285	633
1HME08	Rp 1"	Rp 1"	171	296	467	277	90	285	633
1HME11	Rp 1"	Rp 1"	231	296	527	277	90	285	633
1HME15	Rp 1"	Rp 1"	311	296	607	277	90	285	633
1HME17	Rp 1"	Rp 1"	351	296	647	277	90	285	633
3HME03	Rp 1"	Rp 1"	87	287	374	277	90	285	633
3HME05	Rp 1"	Rp 1"	127	287	414	277	90	285	633
3HME07	Rp 1"	Rp 1"	151	296	447	277	90	285	633
3HME09	Rp 1"	Rp 1"	191	296	487	277	90	285	633
3HME12	Rp 1"	Rp 1"	251	296	547	277	90	285	633
3HME14	Rp 1"	Rp 1"	291	296	587	277	90	285	633
5HME02	Rp 1" 1/4	Rp 1"	104	287	391	277	90	345	693
5HME03	Rp 1" 1/4	Rp 1"	104	287	391	277	90	345	693
5HME04	Rp 1" 1/4	Rp 1"	129	287	416	277	90	345	693
5HME06	Rp 1" 1/4	Rp 1"	158	296	454	277	90	345	693
5HME08	Rp 1" 1/4	Rp 1"	208	296	504	277	90	345	693
5HME10	Rp 1" 1/4	Rp 1"	258	296	554	277	90	345	693
10HME01	Rp 1" 1/2	Rp 1" 1/4	125	297	422	277	90	337	702
10HME02	Rp 1" 1/2	Rp 1" 1/4	125	297	422	277	90	337	702
10HME03	Rp 1" 1/2	Rp 1" 1/4	125	297	422	277	90	337	702
10HME04	Rp 1" 1/2	Rp 1" 1/4	157	297	454	277	90	337	702
15HME01	Rp 2"	Rp 1" 1/2	144	313	457	277	90	337	702
15HME02	Rp 2"	Rp 1" 1/2	144	313	457	277	90	337	702
15HME03	Rp 2"	Rp 1" 1/2	144	361	505	277	90	337	702

smb10\_1-15hm-tri-uk\_a\_td

## SET OF 1 PUMP HME..S SERIES SINGLE-PHASE POWER SUPPLY (SMB10.../M2)

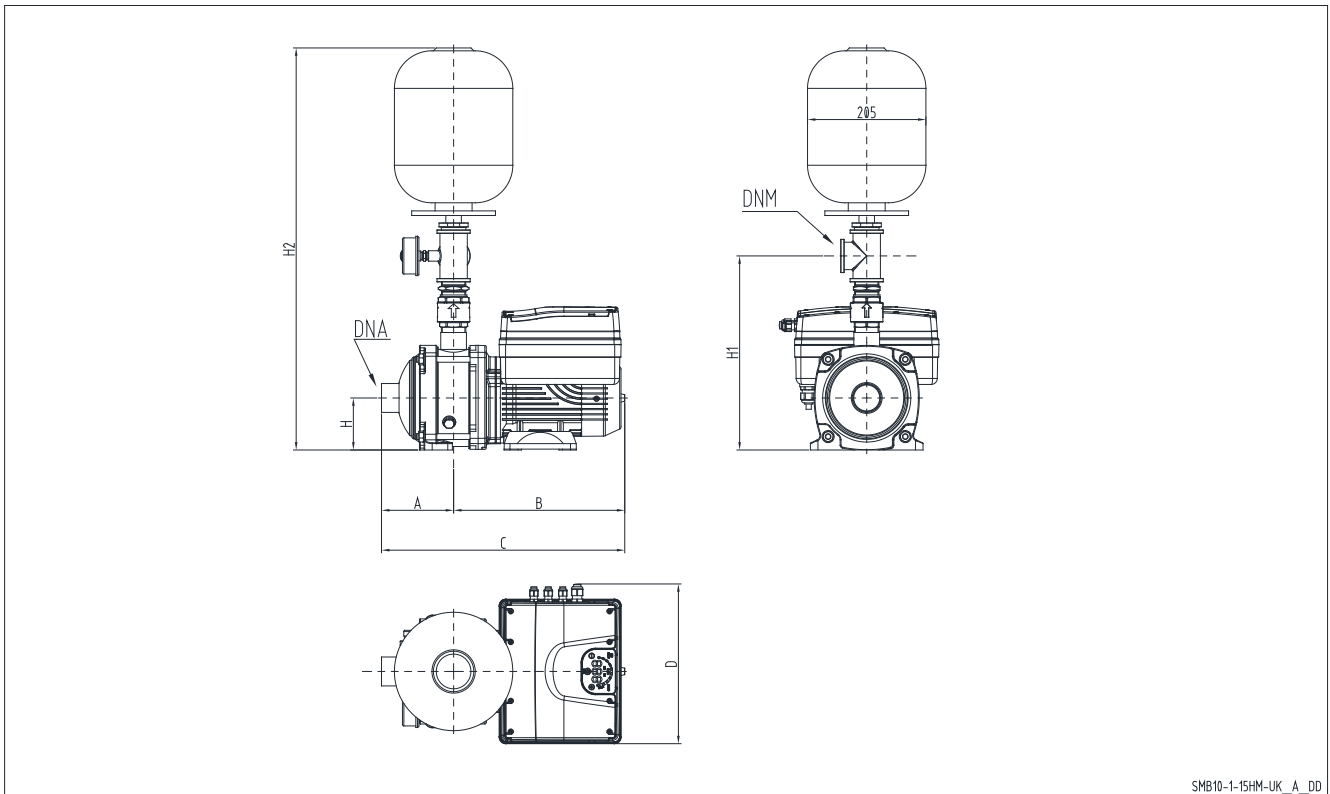

SMB10-1-15HM-UK\_A\_DD

SMB 20	DNA	DNM	A	B	C	D	H	H1	H2
1HME05	Rp 1"	Rp 1"	127	287	414	224	90	285	633
1HME08	Rp 1"	Rp 1"	171	287	467	224	90	285	633
1HME11	Rp 1"	Rp 1"	231	287	527	224	90	285	633
1HME15	Rp 1"	Rp 1"	311	287	607	224	90	285	633
1HME17	Rp 1"	Rp 1"	351	287	647	224	90	285	633
3HME03	Rp 1"	Rp 1"	87	287	374	224	90	285	633
3HME05	Rp 1"	Rp 1"	127	287	414	224	90	285	633
3HME07	Rp 1"	Rp 1"	151	287	447	224	90	285	633
3HME09	Rp 1"	Rp 1"	191	287	487	224	90	285	633
3HME12	Rp 1"	Rp 1"	251	287	547	224	90	285	633
5HME02	Rp 1" 1/4	Rp 1"	104	287	391	224	90	345	693
5HME03	Rp 1" 1/4	Rp 1"	104	287	391	224	90	345	693
5HME04	Rp 1" 1/4	Rp 1"	129	287	416	224	90	345	693
5HME06	Rp 1" 1/4	Rp 1"	158	287	454	224	90	345	693
5HME08	Rp 1" 1/4	Rp 1"	208	287	504	224	90	345	693
10HME01	Rp 1" 1/2	Rp 1" 1/4	125	297	422	224	90	337	702
10HME02	Rp 1" 1/2	Rp 1" 1/4	125	297	422	224	90	337	702
10HME03	Rp 1" 1/2	Rp 1" 1/4	125	297	422	224	90	337	702
15HME01	Rp 2"	Rp 1" 1/2	144	297	457	224	90	337	702
15HME02	Rp 2"	Rp 1" 1/2	144	297	457	224	90	337	702

smb10\_1-15hm-mono-uk\_a\_td

## Booster sets

### MARKET SECTORS

RESIDENTIAL, COMMERCIAL, INDUSTRIAL

## SMB20 Series

### APPLICATIONS

Water supply and pressure boosting in:

- apartments, villas, condominiums and residential buildings
- hotels, restaurants, spas
- various industrial applications

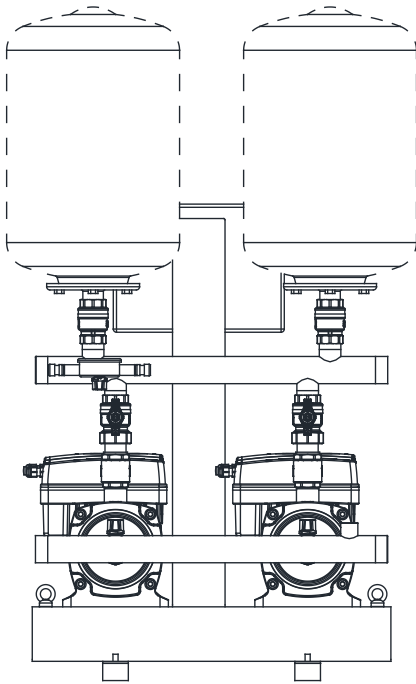

### SPECIFICATIONS

- **e-SVE** vertical axis electric pump.
- **VME** vertical axis close-coupled threaded electric pump.
- **e-HME..S** horizontal axis electric pump.
- **Flow rate:** up to 60 m<sup>3</sup>/h.
- **Head:** up to 158 m
- **Maximum operating pressure:** max 16 bar.
- **Electric panel supply voltage:**  
Standard version:
  - single-phase 1 x 230V ± 10% (SMB../M2).
  - three-phase 3 x 400V ± 10% (SMB../T4).
 Special version:
  - three-phase 3 x 230V ± 10% (SMB../T3).
- **Frequency:** 50Hz.
- **Protection class IP55 for:**
  - electrical control panel
  - electrical pump motor
  - e-SM drive frequency converter
- **Maximum electric pump power:** 2 x 2,2 kW.
- **Progressive motor start.**
- **Maximum pumped liquid temperature:**
  - up to 80 °C for SMB../SVE
  - up to 80 °C for SMB../VME
  - up to 80 °C for SMB../HME..S

**SMB series booster sets with e-SV Smart, VM Smart, e-HM Smart series pumps are certified for use with drinking water.**

## SET OF 2 PUMPS SVE..F SERIES SINGLE-PHASE POWER SUPPLY (SMB20.../M2)

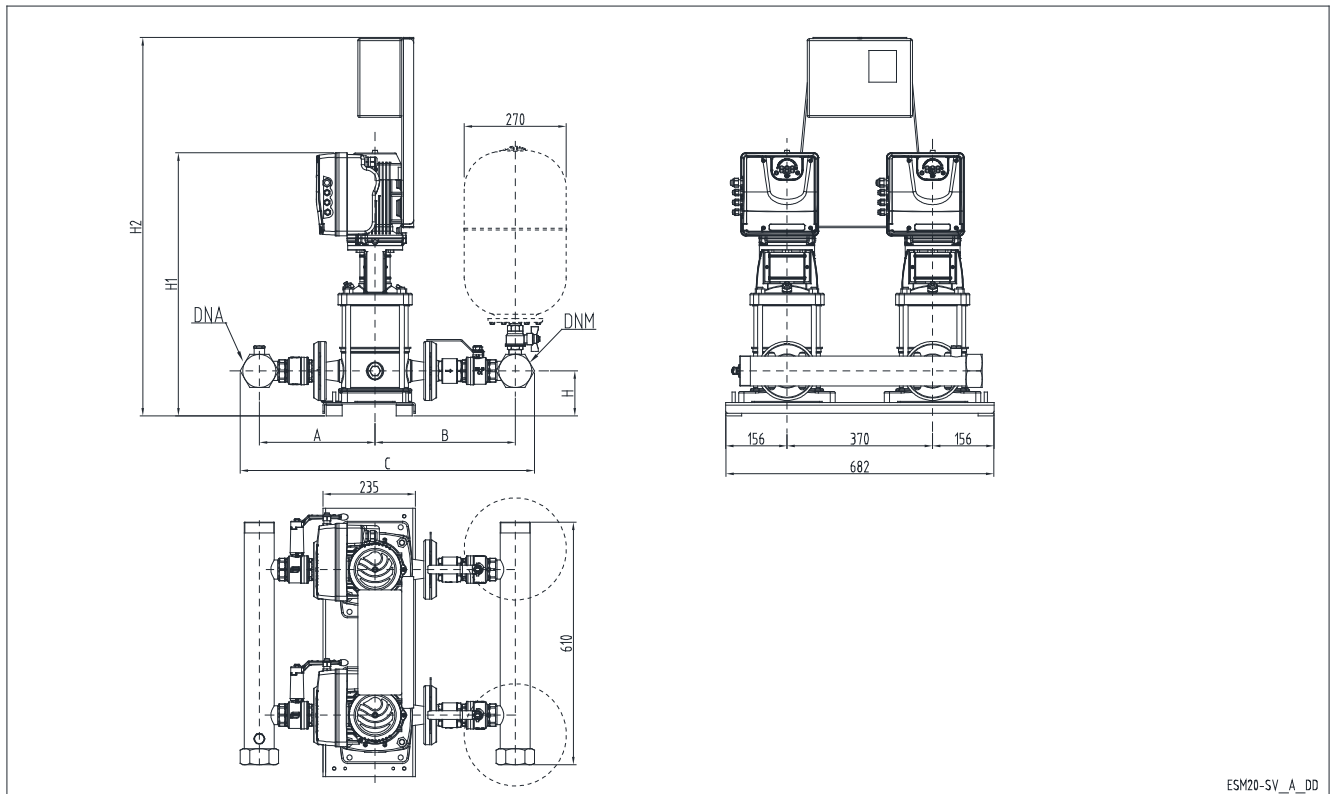

ESM20-SV\_A\_DD

SMB 20	DNA	DNM	A		B		C		H	H1	H2
			STD	AISI	STD	AISI	STD	AISI			
1SVE05F003	R2"	R2"	256	257	311	363	627	680	109	614	926
1SVE08F005	R2"	R2"	256	257	311	363	627	680	109	674	986
1SVE11F007	R2"	R2"	256	257	311	363	627	680	109	734	1046
1SVE15F011	R2"	R2"	256	257	311	363	627	680	109	814	1126
3SVE03F003	R2"	R2"	256	257	311	363	627	680	109	574	886
3SVE05F005	R2"	R2"	256	257	311	363	627	680	109	614	926
3SVE07F007	R2"	R2"	256	257	311	363	627	680	109	654	966
3SVE09F011	R2"	R2"	256	257	311	363	627	680	109	694	1006
3SVE11F015	R2"	R2"	256	257	311	363	627	680	109	734	1046
5SVE02F003	R2"	R2"	260	267	329	387	649	714	109	564	876
5SVE03F005	R2"	R2"	260	267	329	387	649	714	109	589	901
5SVE04F007	R2"	R2"	260	267	329	387	649	714	109	614	926
5SVE06F011	R2"	R2"	260	267	329	387	649	714	109	664	976
5SVE08F015	R2"	R2"	260	267	329	387	649	714	109	714	1026
10SVE01F005	R2"1/2	R2"1/2	294	301	356	453	726	830	114	643	955
10SVE02F007	R2"1/2	R2"1/2	294	301	356	453	726	830	114	643	955
10SVE02F011	R2"1/2	R2"1/2	294	301	356	453	726	830	114	643	955
10SVE03F015	R2"1/2	R2"1/2	294	301	356	453	726	830	114	675	987

Dimensions in mm. ± 10 mm tolerance range.

smb20-sv-f\_b\_td

## SET OF 2 PUMPS SVE..F SERIES SINGLE-PHASE POWER SUPPLY (SMB20.../M2)

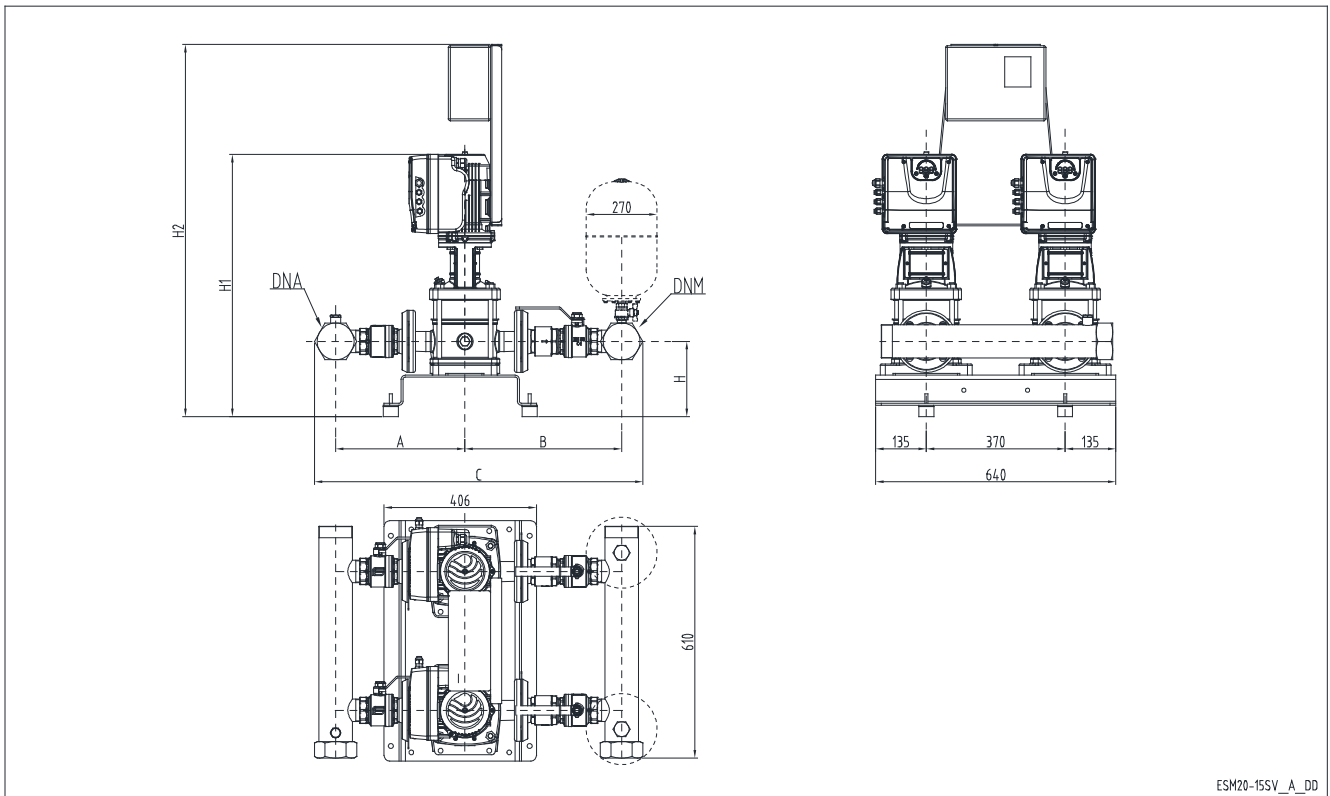

ESM20-15SV\_A\_DD

SMB 20	DNA	DNM	A		B		C		H	H1	H2
			STD	AISI	STD	AISI	STD	AISI			
15SVE01F007	R3"	R3"	345	367	418	423	851	880	200	771	1083
15SVE01F011	R3"	R3"	345	367	418	423	851	880	200	771	1083
15SVE02F015	R3"	R3"	345	367	418	423	851	880	200	771	1083
22SVE01F007	R3"	R3"	345	367	418	423	851	880	200	771	1083
22SVE01F011	R3"	R3"	345	367	418	423	851	880	200	771	1083
22SVE02F015	R3"	R3"	345	367	418	423	851	880	200	771	1083

Dimensions in mm. ± 10 mm tolerance range.

smb20-15sv-f\_a\_td

## SET OF 2 PUMPS SVE..R SERIES SINGLE-PHASE POWER SUPPLY (SMB20.../M2)

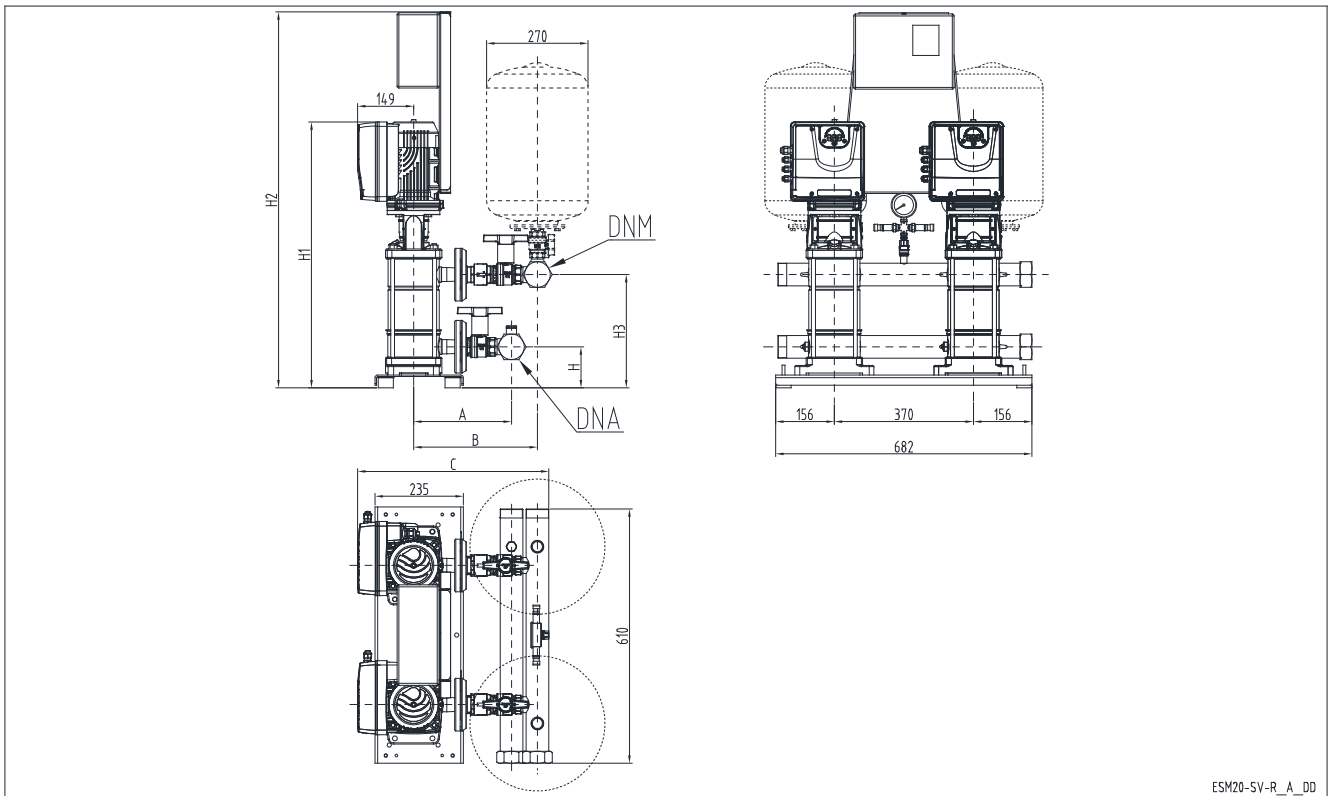

ESM20-SV-R\_A\_DD

SMB 20	DNA	DNM	A		B		C		H	H1	H2	H3
			STD	AISI	STD	AISI	STD	AISI				
1SVE08R005	R2"	R2"	256	257	311	363	490	542	109	674	986	261
1SVE11R007	R2"	R2"	256	257	311	363	490	542	109	734	1046	321
1SVE15R011	R2"	R2"	256	257	311	363	490	542	109	814	1126	401
3SVE07R007	R2"	R2"	256	257	311	363	490	542	109	654	966	241
3SVE09R011	R2"	R2"	256	257	311	363	490	542	109	694	1006	281
3SVE11R015	R2"	R2"	256	257	311	363	490	542	109	734	1046	301
5SVE08R015	R2"	R2"	260	267	329	387	508	566	109	714	1026	301

Dimensions in mm. ± 10 mm tolerance range.

smb20-sv-r\_b\_td

## SET OF 2 PUMPS VME SERIES SINGLE-PHASE POWER SUPPLY (SMB20.../M2)

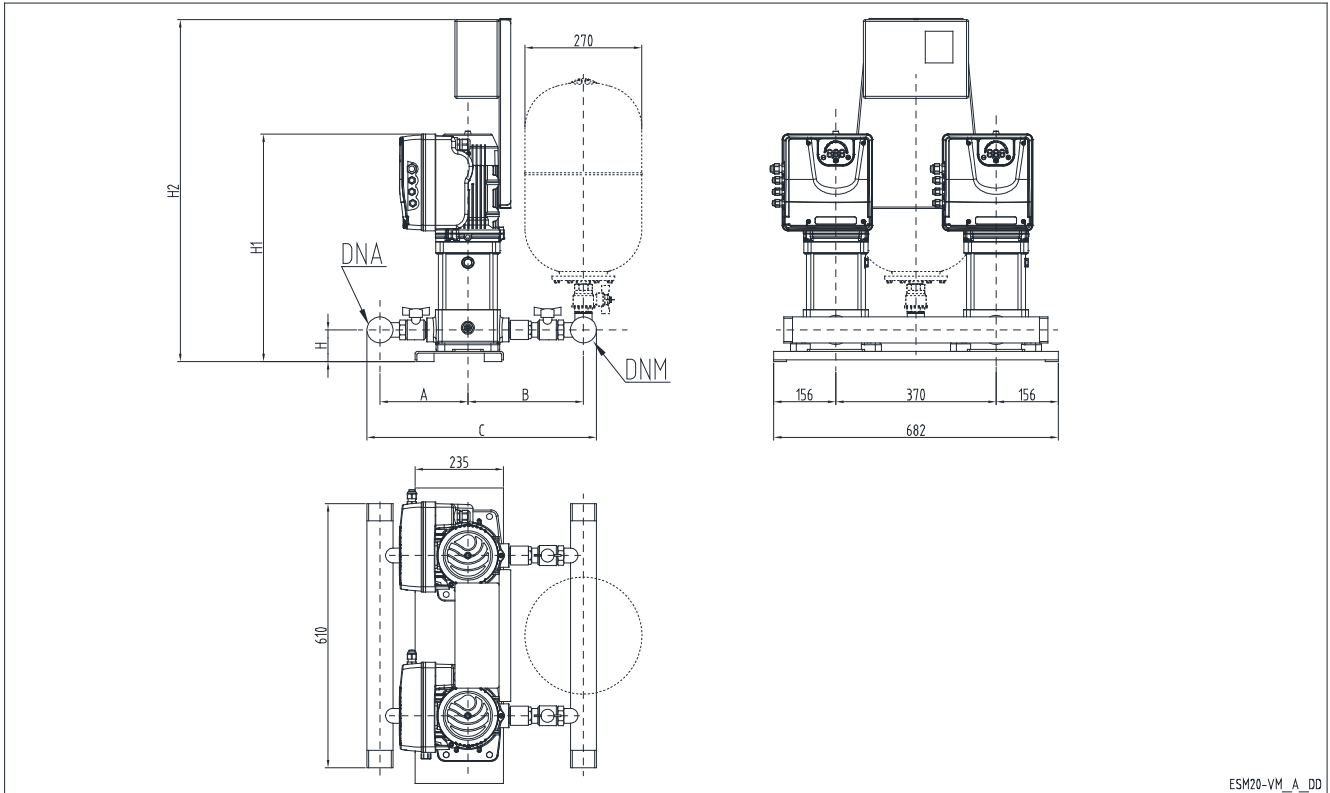

SMB 20	DNA	DNM	A		B		C		H	H1	H2
			STD	AISI	STD	AISI	STD	AISI			
1VME02P03	R2"	R2"	232	314	287	419	579	793	84	449	761
1VME04P05	R2"	R2"	232	314	287	419	579	793	84	469	781
1VME05P07	R2"	R2"	232	314	287	419	579	793	84	489	801
1VME06P11	R2"	R2"	232	314	287	419	579	793	84	509	821
3VME02P03	R2"	R2"	232	314	287	419	579	793	84	449	761
3VME03P05	R2"	R2"	232	314	287	419	579	793	84	449	761
3VME04P07	R2"	R2"	232	314	287	419	579	793	84	469	781
3VME05P11	R2"	R2"	232	314	287	419	579	793	84	469	781
3VME06P15	R2"	R2"	232	314	287	419	579	793	84	509	821
5VME02P05	R2"	R2"	251	329	316	449	627	838	84	449	761
5VME03P07	R2"	R2"	251	329	316	449	627	838	84	449	761
5VME04P11	R2"	R2"	251	329	316	449	627	838	84	469	781
5VME05P15	R2"	R2"	251	329	316	449	627	838	84	469	781
10VME01P07	R2"1/2	R2"1/2	286	374	348	517	710	967	114	513	825
10VME02P11	R2"1/2	R2"1/2	286	374	348	517	710	967	114	513	825

Dimensions in mm. ± 10 mm tolerance range.

smb20-vm\_c\_td

## SET OF 2 PUMPS HME..S SERIES SINGLE-PHASE POWER SUPPLY (SMB20.../M2)

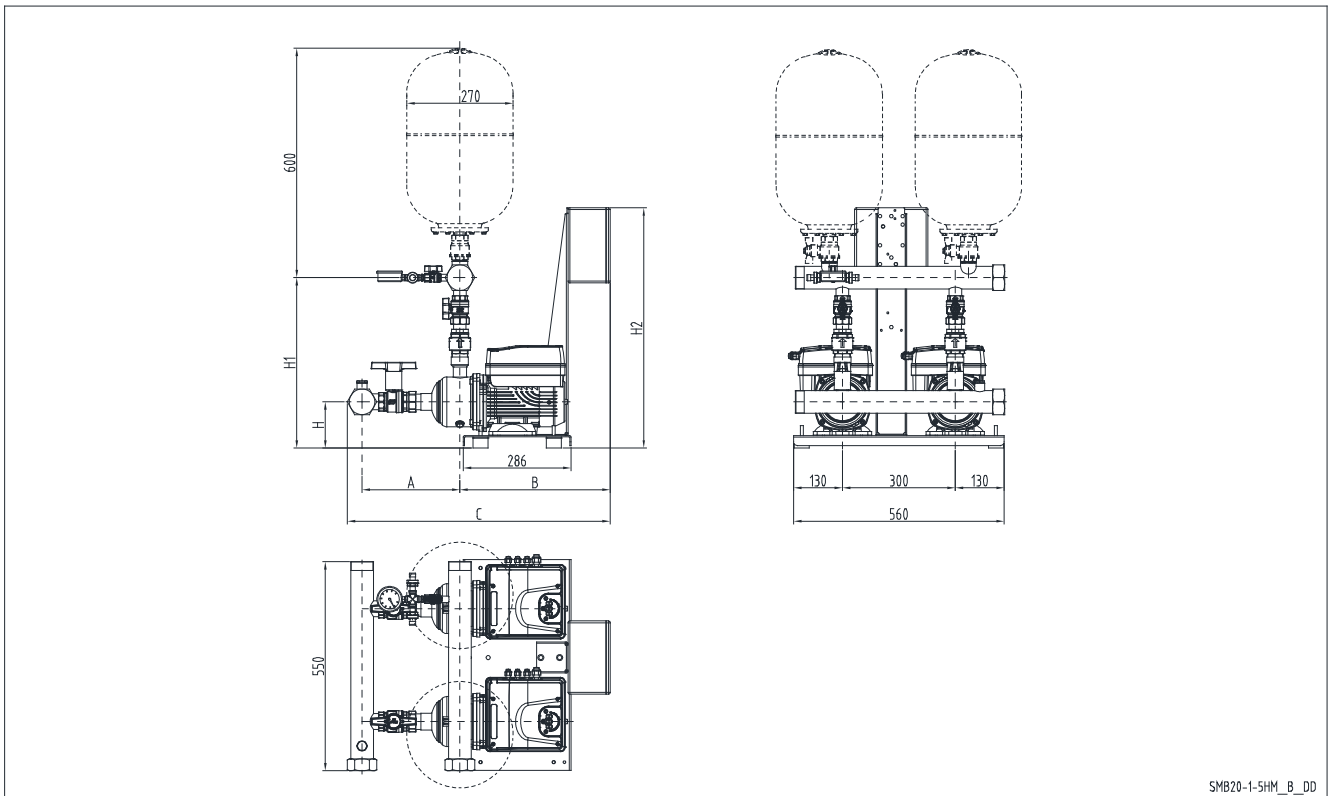

SMB 20	DNA	DNM	A		B	C		H	H1		H2
			STD	AISI		STD	AISI		STD	AISI	
1HME05	R 2"	R 2"	264	308	400	694	747	123	408	446	639
3HME03	R 2"	R 2"	224	268	400	654	707	123	408	446	639
3HME05	R 2"	R 2"	264	308	400	694	747	123	408	446	639
5HME02	R 2"	R 2"	260	320	400	690	759	123	453	527	639
5HME03	R 2"	R 2"	260	320	400	690	759	123	453	527	639
5HME04	R 2"	R 2"	285	345	400	715	784	123	453	527	639

Dimensions in mm. ± 10 mm tolerance range.

smb20\_1-5hms\_b\_td

## SET OF 2 PUMPS HME..S SERIES SINGLE-PHASE POWER SUPPLY (SMB20.../M2)

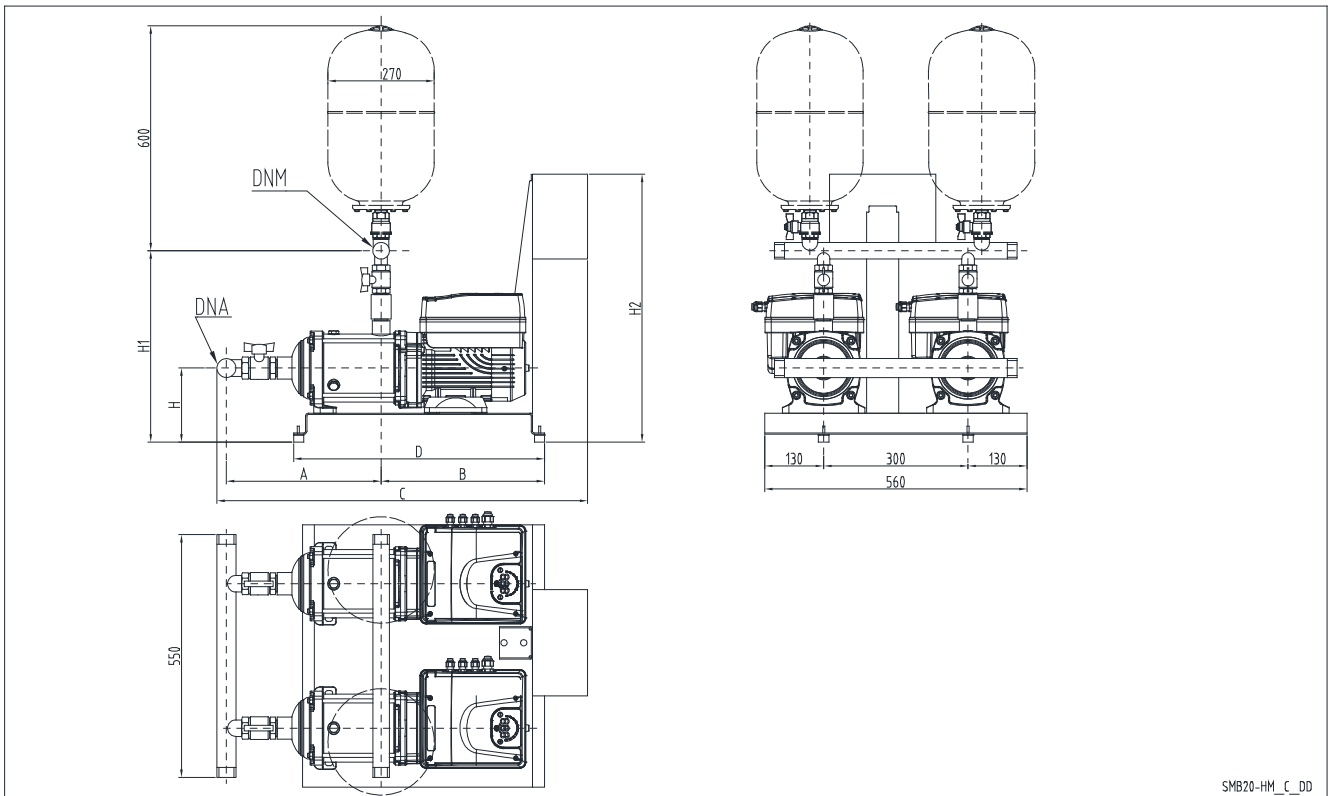

SMB 20	DNA	DNM	A		B	C		D	H	H1		H2
			STD	AISI		STD	AISI			STD	AISI	
1HME08	R 2"	R 2"	308	352	349	747	791	590	205	490	528	720
1HME11	R 2"	R 2"	368	412	349	807	851	590	205	490	528	720
1HME15	R 2"	R 2"	448	492	349	887	931	762	205	490	528	720
1HME17	R 2"	R 2"	488	532	349	927	971	762	205	490	528	720
3HME07	R 2"	R 2"	288	332	349	727	771	590	205	490	528	720
3HME09	R 2"	R 2"	328	372	349	767	811	590	205	490	528	720
3HME12	R 2"	R 2"	388	432	349	827	871	590	205	490	528	720
5HME06	R 2"	R 2"	314	374	349	753	813	590	205	551	625	720
5HME08	R 2"	R 2"	364	424	349	803	863	590	205	551	625	720
10HME01	R 2"1/2	R 2"1/2	301	361	350	749	809	590	205	611	709	720
10HME02	R 2"1/2	R 2"1/2	301	361	350	749	809	590	205	611	709	720
10HME03	R 2"1/2	R 2"1/2	301	361	350	749	809	590	205	611	709	720

Dimensions in mm. ± 10 mm tolerance range.

smb20\_1-10hms\_d\_td

### SET OF 2 PUMPS HME..S SERIES SINGLE-PHASE POWER SUPPLY (SMB20.../M2)

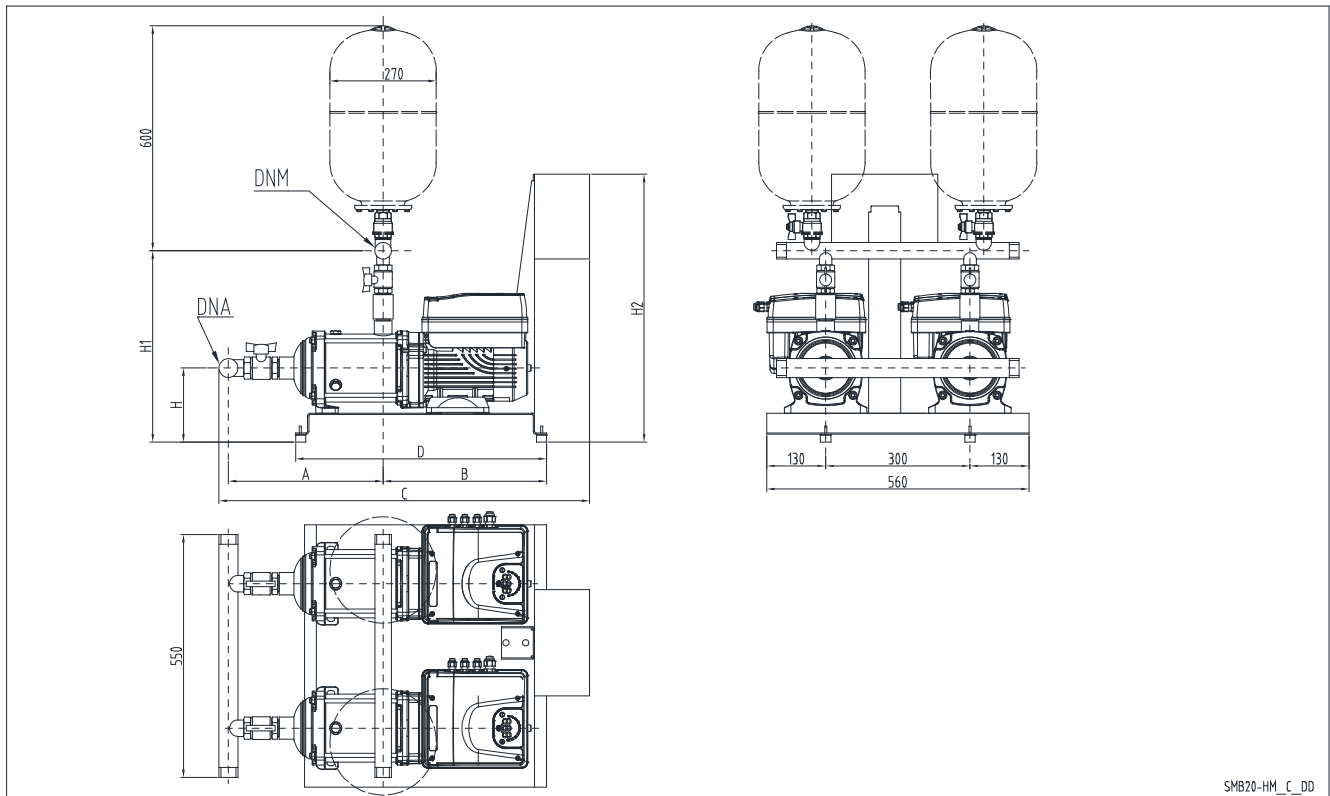

SMB 20	DNA	DNM	A		B	C		D	H	H1		H2
			STD	AISI		STD	AISI			STD	AISI	
15HME01	R3"	R3"	362	422	366	832	892	590	205	651	704	720
15HME02	R3"	R3"	362	422	366	832	892	590	205	651	704	720

Dimensions in mm. ± 10 mm tolerance range.

smb20\_15hm\_b\_td

## SET OF 2 PUMPS SVE..F SERIES THREE-PHASE POWER SUPPLY (SMB20.../T3-T4)

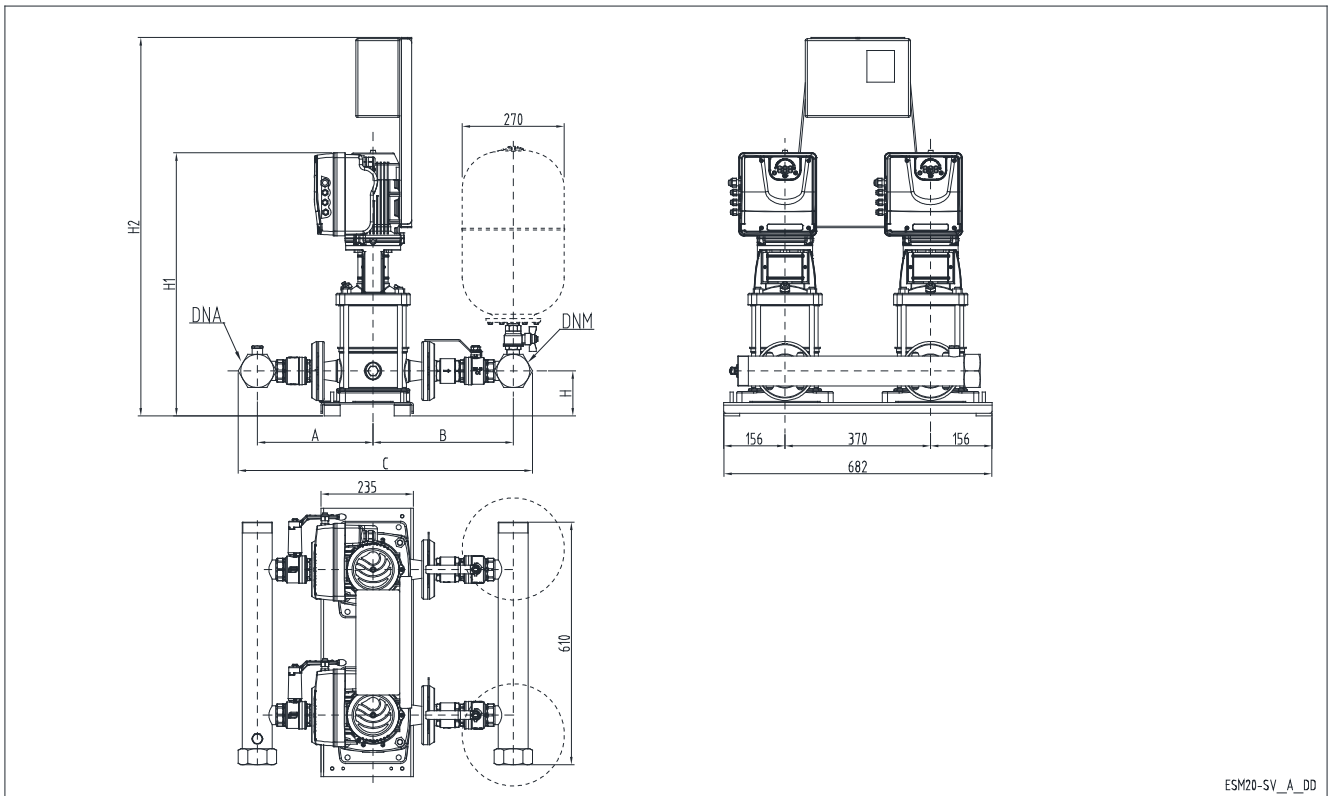

ESM20-SV\_A\_DD

SMB 20	DNA	DNM	A		B		C		H	H1	H2
			STD	AISI	STD	AISI	STD	AISI			
1SVE05F003	R2"	R2"	256	257	311	363	627	680	109	614	926
1SVE08F005	R2"	R2"	256	257	311	363	627	680	109	674	986
1SVE11F007	R2"	R2"	256	257	311	363	627	680	109	734	1046
1SVE15F011	R2"	R2"	256	257	311	363	627	680	109	814	1126
3SVE03F003	R2"	R2"	256	257	311	363	627	680	109	574	886
3SVE05F005	R2"	R2"	256	257	311	363	627	680	109	614	926
3SVE07F007	R2"	R2"	256	257	311	363	627	680	109	654	966
3SVE09F011	R2"	R2"	256	257	311	363	627	680	109	694	1006
3SVE11F015	R2"	R2"	256	257	311	363	627	680	109	734	1046
5SVE02F003	R2"	R2"	260	267	329	387	649	714	109	564	876
5SVE03F005	R2"	R2"	260	267	329	387	649	714	109	589	901
5SVE04F007	R2"	R2"	260	267	329	387	649	714	109	614	926
5SVE06F011	R2"	R2"	260	267	329	387	649	714	109	664	976
5SVE08F015	R2"	R2"	260	267	329	387	649	714	109	714	1026
5SVE12F022	R2"	R2"	260	267	329	387	649	714	109	814	1126
10SVE01F005	R2"1/2	R2"1/2	294	301	356	453	726	830	114	643	955
10SVE02F007	R2"1/2	R2"1/2	294	301	356	453	726	830	114	643	955
10SVE02F011	R2"1/2	R2"1/2	294	301	356	453	726	830	114	643	955
10SVE03F015	R2"1/2	R2"1/2	294	301	356	453	726	830	114	675	987
10SVE04F022	R2"1/2	R2"1/2	294	301	356	453	726	830	114	707	1019

Dimensions in mm. ± 10 mm tolerance range.

smb20-sv-f-tri\_a\_td

### SET OF 2 PUMPS SVE..F SERIES THREE-PHASE POWER SUPPLY (SMB20.../T3-T4)

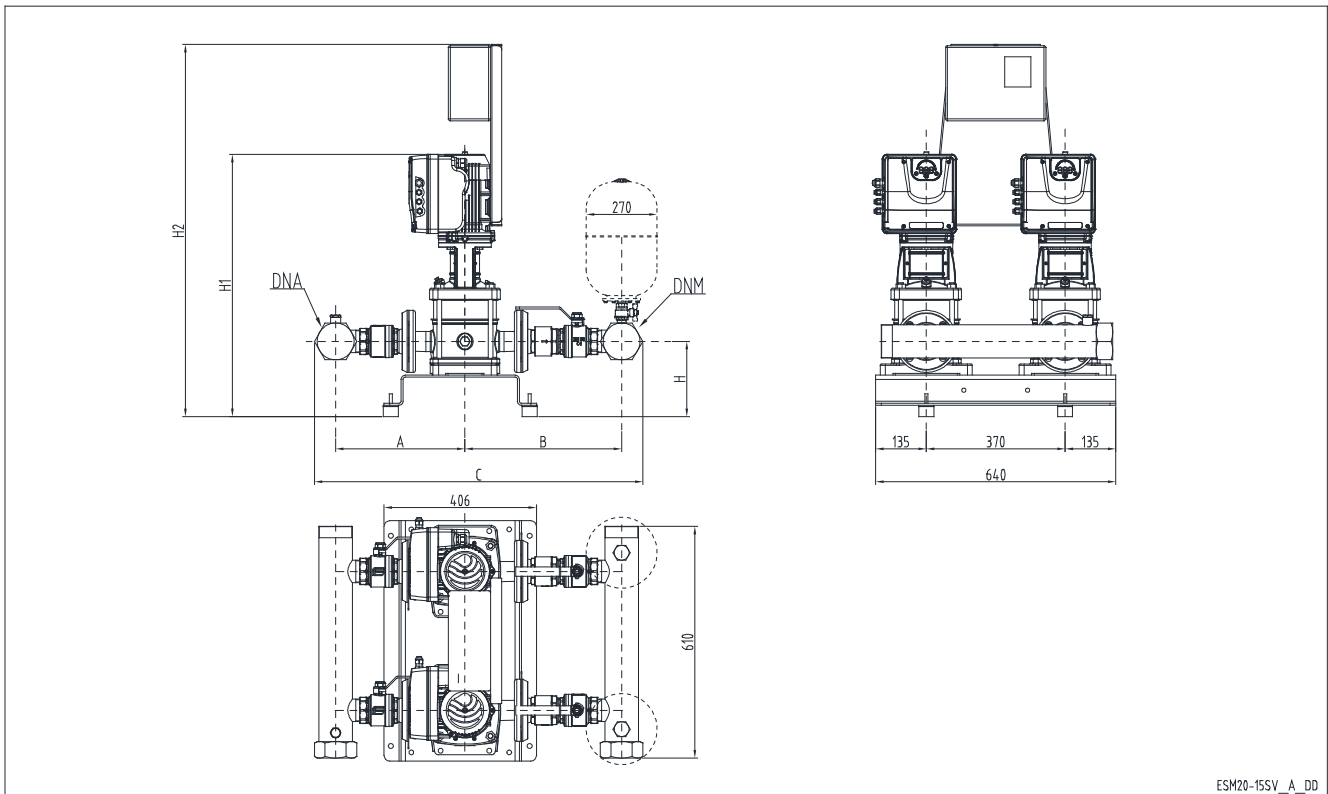

ESM20-15SV\_A\_DD

SMB 20	DNA	DNM	A		B		C		H	H1	H2
			STD	AISI	STD	AISI	STD	AISI			
15SVE01F007	R3"	R3"	345	367	418	423	851	880	200	771	1083
15SVE01F011	R3"	R3"	345	367	418	423	851	880	200	771	1083
15SVE02F015	R3"	R3"	345	367	418	423	851	880	200	771	1083
15SVE02F022	R3"	R3"	345	367	418	423	851	880	200	771	1083
22SVE01F007	R3"	R3"	345	367	418	423	851	880	200	771	1083
22SVE01F011	R3"	R3"	345	367	418	423	851	880	200	771	1083
22SVE02F015	R3"	R3"	345	367	418	423	851	880	200	771	1083
22SVE02F022	R3"	R3"	345	367	418	423	851	880	200	771	1083

Dimensions in mm. ± 10 mm tolerance range.

smb20-15sv-f-tri\_a\_td

## SET OF 2 PUMPS SVE..R SERIES THREE-PHASE POWER SUPPLY (SMB20.../M2)

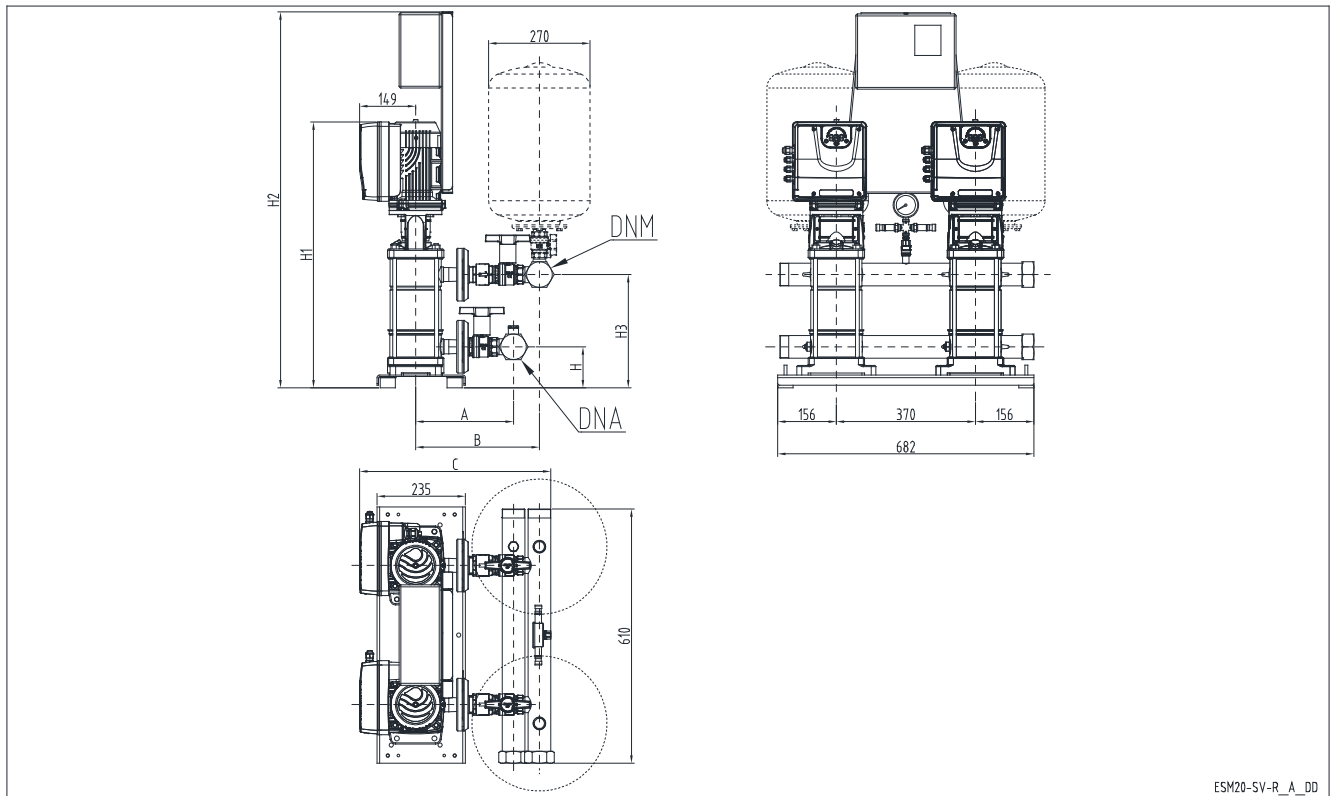

ESM20-SV-R\_A\_DD

SMB 20	DNA	DNM	A		B		C		H	H1	H2	H3
			STD	AISI	STD	AISI	STD	AISI				
1SVE08R005	R2"	R2"	256	257	311	363	490	542	109	674	986	261
1SVE11R007	R2"	R2"	256	257	311	363	490	542	109	734	1046	321
1SVE15R011	R2"	R2"	256	257	311	363	490	542	109	814	1126	401
3SVE07R007	R2"	R2"	256	257	311	363	490	542	109	654	966	241
3SVE09R011	R2"	R2"	256	257	311	363	490	542	109	694	1006	281
3SVE11R015	R2"	R2"	256	257	311	363	490	542	109	734	1046	301
5SVE08R015	R2"	R2"	260	267	329	387	508	566	109	714	1026	301
5SVE12R022	R2"	R2"	260	267	329	387	508	566	109	814	1126	301

Dimensions in mm. ± 10 mm tolerance range.

smb20-sv-r-tri\_a\_td

### SET OF 2 PUMPS VME SERIES THREE-PHASE POWER SUPPLY (SMB20.../T3-T4)

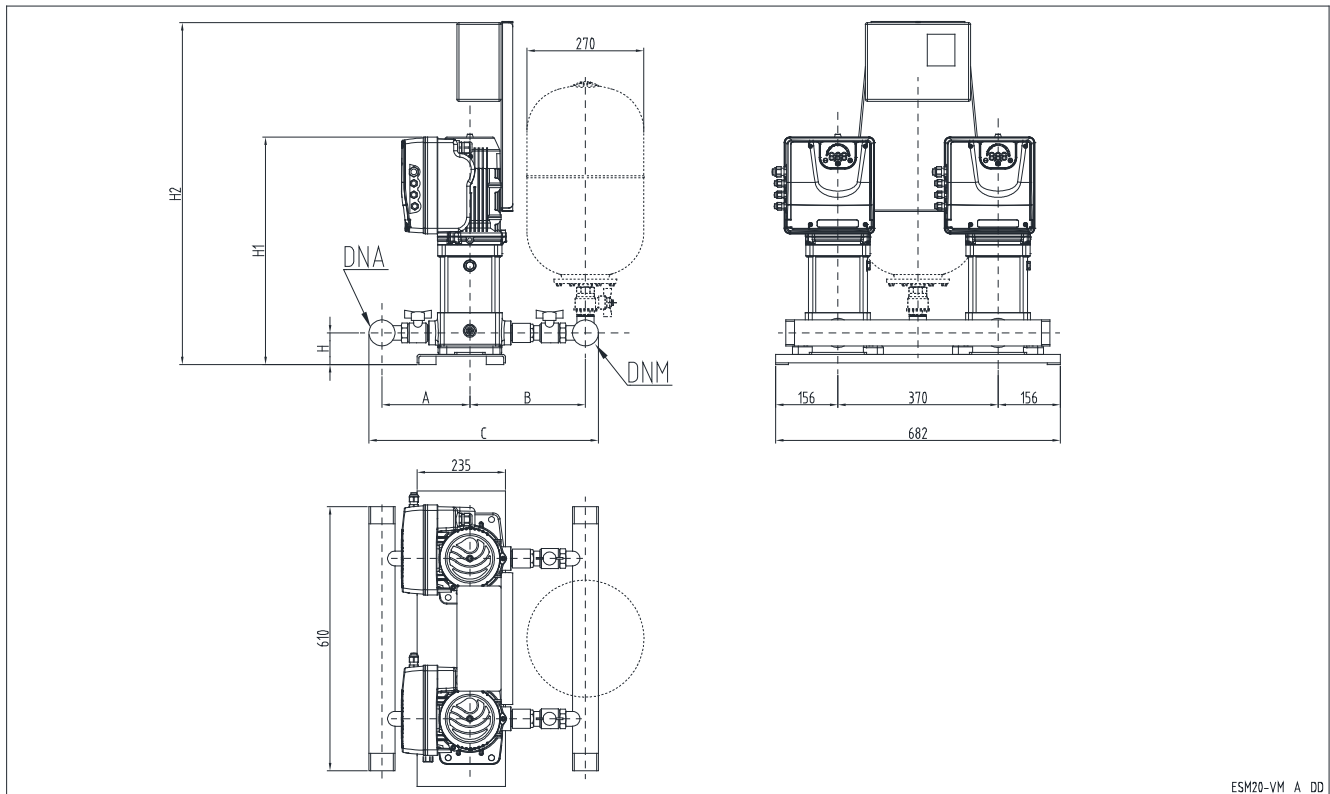

ESM20-VM\_A\_DD

SMB 20	DNA	DNM	A		B		C		H	H1	H2
			STD	AISI	STD	AISI	STD	AISI			
1VME02P03	R2"	R2"	232	314	287	419	579	793	84	449	761
1VME04P05	R2"	R2"	232	314	287	419	579	793	84	469	781
1VME05P07	R2"	R2"	232	314	287	419	579	793	84	489	801
1VME06P11	R2"	R2"	232	314	287	419	579	793	84	509	821
3VME02P03	R2"	R2"	232	314	287	419	579	793	84	449	761
3VME03P05	R2"	R2"	232	314	287	419	579	793	84	449	761
3VME04P07	R2"	R2"	232	314	287	419	579	793	84	469	781
3VME05P11	R2"	R2"	232	314	287	419	579	793	84	469	781
3VME06P15	R2"	R2"	232	314	287	419	579	793	84	509	821
5VME02P05	R2"	R2"	251	329	316	449	627	838	84	449	761
5VME03P07	R2"	R2"	251	329	316	449	627	838	84	449	761
5VME04P11	R2"	R2"	251	329	316	449	627	838	84	469	781
5VME05P15	R2"	R2"	251	329	316	449	627	838	84	489	801
5VME06P22	R2"	R2"	251	329	316	449	627	838	84	509	821
10VME01P07	R2"1/2	R2"1/2	286	374	348	517	710	967	114	513	825
10VME02P11	R2"1/2	R2"1/2	286	374	348	517	710	967	114	513	825

Dimensions in mm. ± 10 mm tolerance range.

smb20-vm-tri\_a\_td

## SET OF 2 PUMPS HME...S SERIES THREE-PHASE POWER SUPPLY (SMB20.../T3-T4)

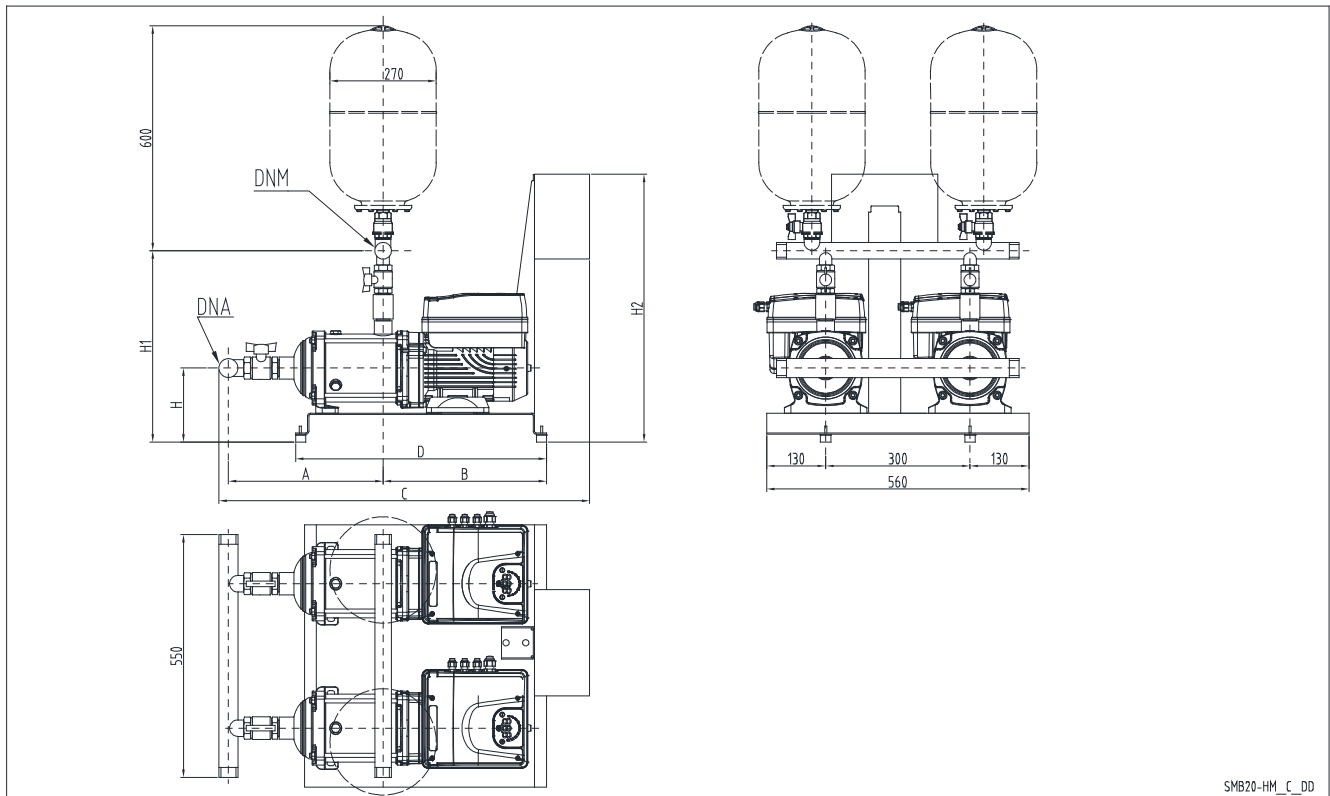

SMB20-HM\_C\_DD

SMB 20	DNA	DNM	A		B	C		D	H	H1		H2
			STD	AISI		STD	AISI			STD	AISI	
1HME08	R 2"	R 2"	308	352	349	775	819	590	205	490	528	829
1HME11	R 2"	R 2"	368	412	349	835	879	590	205	490	528	829
1HME15	R 2"	R 2"	448	492	349	915	959	762	205	490	528	829
1HME17	R 2"	R 2"	488	532	349	955	999	762	205	490	528	829
3HME07	R 2"	R 2"	288	332	349	755	799	590	205	490	528	829
3HME09	R 2"	R 2"	328	372	349	795	839	590	205	490	528	829
3HME12	R 2"	R 2"	388	432	349	855	899	590	205	490	528	829
3HME14	R 2"	R 2"	428	472	349	895	939	590	205	490	528	829
5HME06	R 2"	R 2"	314	374	349	781	841	590	205	551	625	829
5HME08	R 2"	R 2"	364	424	349	831	891	590	205	551	625	829
5HME10	R 2"	R 2"	414	474	349	881	941	590	205	551	625	829
10HME01	R 2"1/2	R 2"1/2	301	361	350	777	837	590	205	611	709	829
10HME02	R 2"1/2	R 2"1/2	301	361	350	777	837	590	205	611	709	829
10HME03	R 2"1/2	R 2"1/2	301	361	350	777	837	590	205	611	709	829
10HME04	R 2"1/2	R 2"1/2	333	393	350	809	869	590	205	611	709	829

Dimensions in mm. ± 10 mm tolerance range.

smb20\_1-10hms-tri\_a\_td

**SET OF 2 PUMPS HME..S SERIES  
THREE-PHASE POWER SUPPLY (SMB20.../T3-T4)**

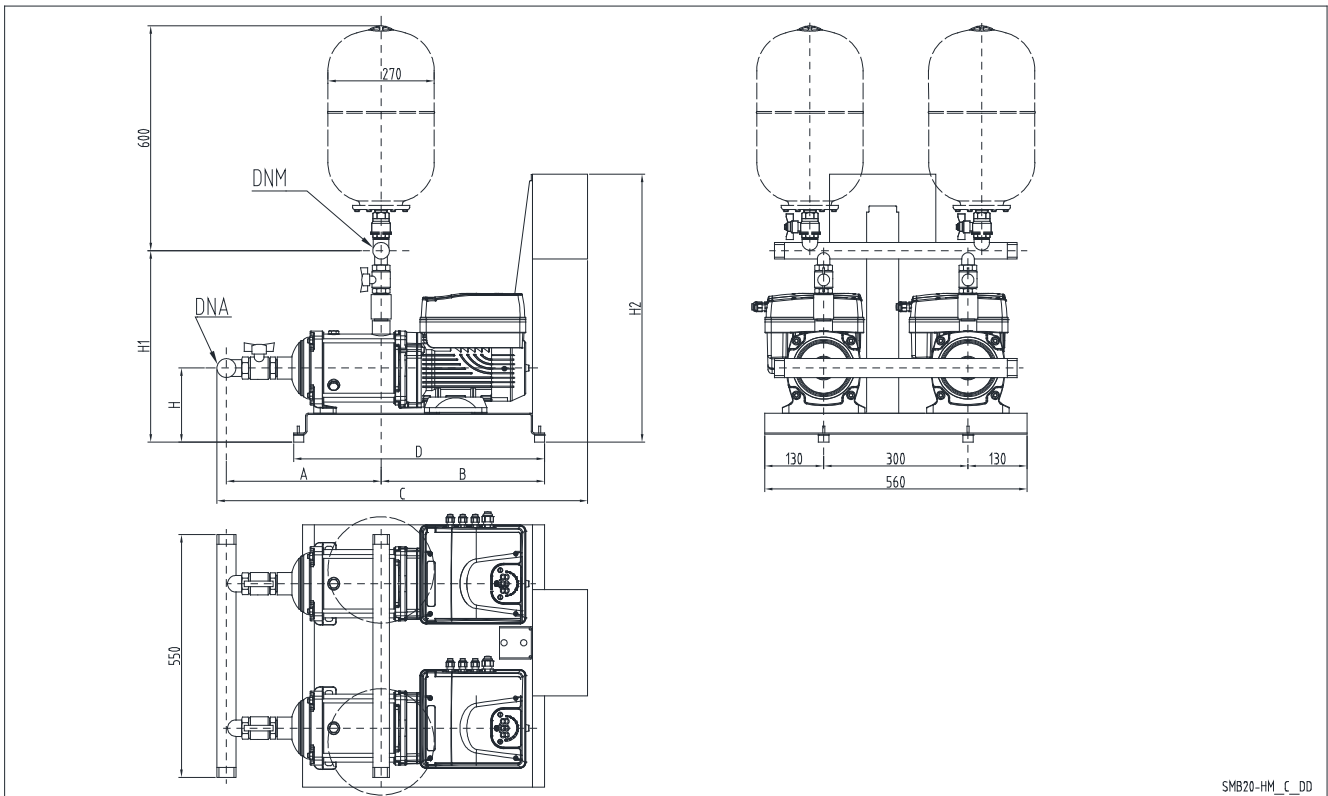

SMB 20	DNA	DNM	A		B	C		D	H	H1		H2
			STD	AISI		STD	AISI			STD	AISI	
15HME01	R3"	R3"	362	422	366	860	920	590	205	651	704	829
15HME02	R3"	R3"	362	422	366	860	920	590	205	651	704	829
15HME03	R3"	R3"	362	422	366	860	920	590	205	651	704	829

Dimensions in mm. ± 10 mm tolerance range.

smb20\_15hms-tri\_a\_td

**SET OF 2 PUMPS HME..S SERIES  
THREE-PHASE POWER SUPPLY (SMB20.../T3-T4)**

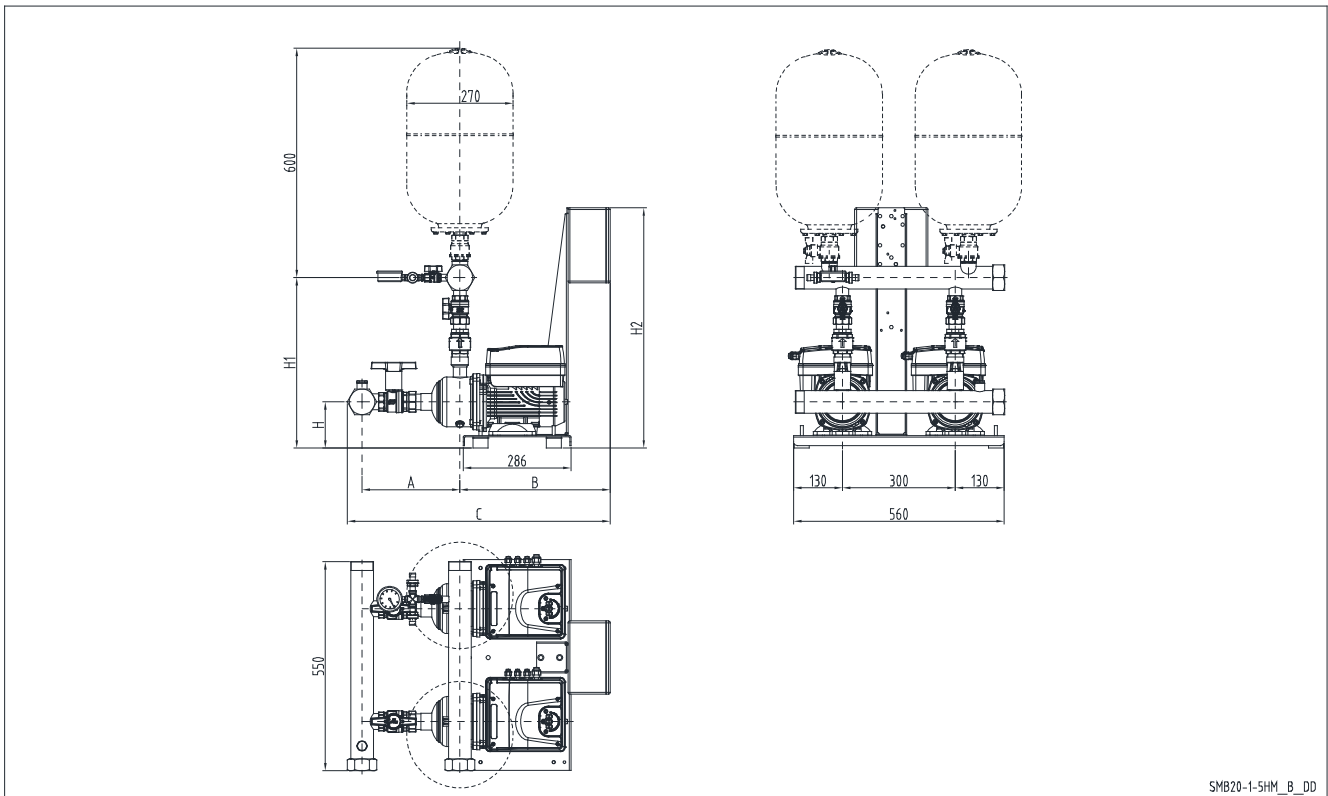

SMB 20	DNA	DNM	A		B	C		H	H1		H2
			STD	AISI		STD	AISI		STD	AISI	
1HME05	R 2"	R 2"	264	308	428	722	747	123	408	446	747
3HME03	R 2"	R 2"	224	268	428	682	707	123	408	446	747
3HME05	R 2"	R 2"	264	308	428	722	747	123	408	446	747
5HME02	R 2"	R 2"	260	320	428	718	759	123	453	527	747
5HME03	R 2"	R 2"	260	320	428	718	759	123	453	527	747
5HME04	R 2"	R 2"	285	345	428	743	784	123	453	527	747

Dimensions in mm. ± 10 mm tolerance range.

smb20\_1-5hms-tri\_a\_td

## Booster sets

### MARKET SECTORS

RESIDENTIAL, COMMERCIAL, INDUSTRIAL

## SMB30 Series

### APPLICATIONS

Water supply and pressure boosting in:

- apartments, villas, condominiums and residential buildings
- hotels, restaurants, spas
- various industrial applications

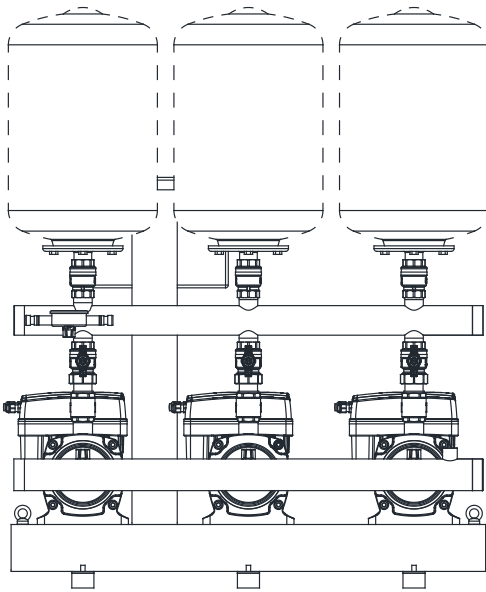

### SPECIFICATIONS

- **e-SVE** vertical axis electric pump.
- **VME** vertical axis close-coupled threaded electric pump.
- **e-HME..S** horizontal axis electric pump.
- **Flow rate:** up to 90 m<sup>3</sup>/h.
- **Head:** up to 158 m
- **Maximum operating pressure:** max 16 bar.
- **Electric panel supply voltage:**  
Standard version:  
- single-phase 1 x 230V ± 10% (SMB../M2).  
- three-phase 3 x 400V ± 10% (SMB../T4).  
Special version:  
- three-phase 3 x 230V ± 10% (SMB../T3).
- **Frequency:** 50Hz.
- **Protection class IP55 for:**  
- electrical control panel  
- electrical pump motor  
- e-SM drive frequency converter
- **Maximum electric pump power:** 3 x 2,2 kW.
- **Progressive motor start.**
- **Maximum pumped liquid temperature:**  
- up to 80 °C for SMB../SVE  
- up to 80 °C for SMB../VME  
- up to 80 °C for SMB../HME..S

**SMB series booster sets with e-SV Smart, VM Smart, e-HM Smart series pumps are certified for use with drinking water.**

## SET OF 3 PUMPS SVE..F SERIES SINGLE-PHASE POWER SUPPLY (SMB30.../M2)

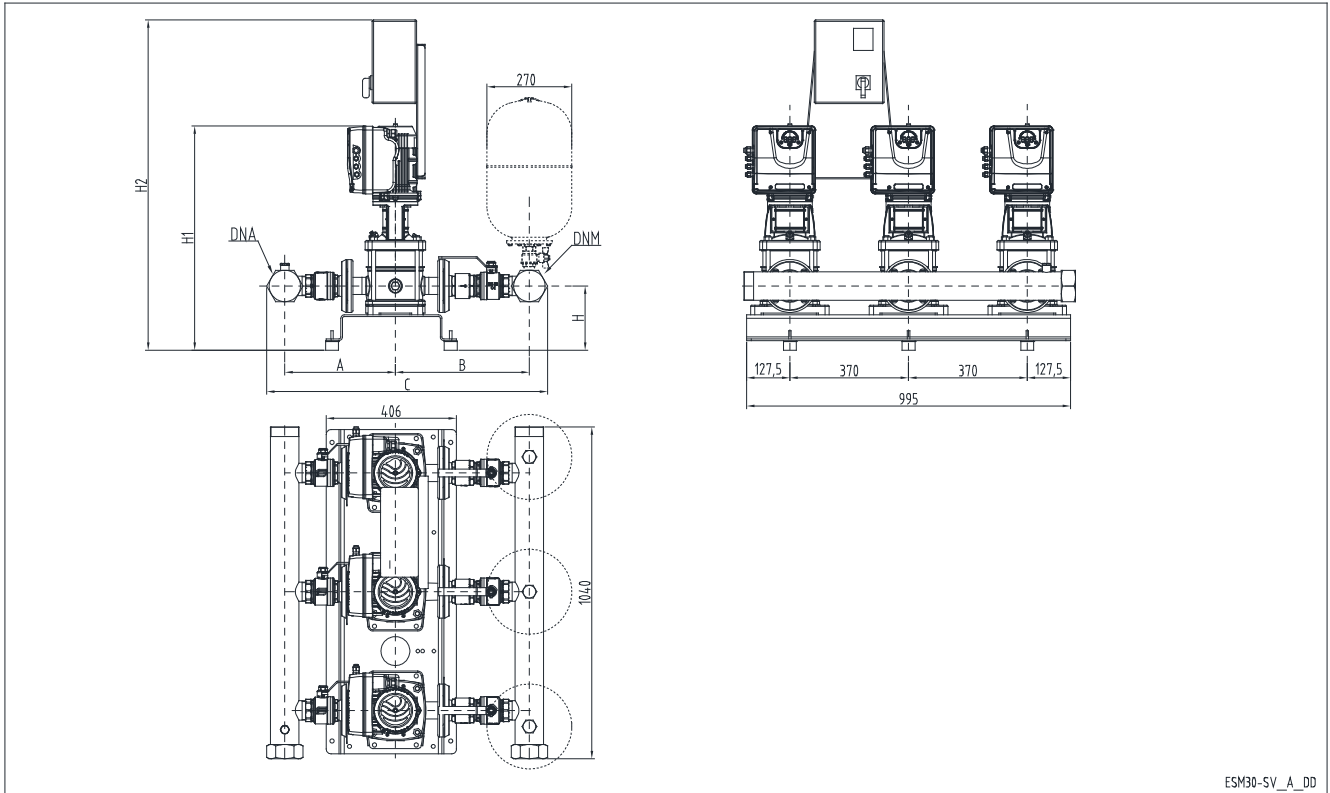

SMB 30	DNA	DNM	A		B		C		H	H1	H2
			STD	AISI	STD	AISI	STD	AISI			
1SVE05F003	R2"	R2"	256	257	311	363	627	680	185	690	976
1SVE08F005	R2"	R2"	256	257	311	363	627	680	185	750	1036
1SVE11F007	R2"	R2"	256	257	311	363	627	680	185	810	1096
1SVE15F011	R2"	R2"	256	257	311	363	627	680	185	890	1176
3SVE03F003	R2"	R2"	256	257	311	363	627	680	185	650	936
3SVE05F005	R2"	R2"	256	257	311	363	627	680	185	690	976
3SVE07F007	R2"	R2"	256	257	311	363	627	680	185	730	1016
3SVE09F011	R2"	R2"	256	257	311	363	627	680	185	770	1056
3SVE11F015	R2"	R2"	256	257	311	363	627	680	185	810	1096
5SVE02F003	R2"	R2"	260	267	329	387	649	714	185	640	926
5SVE03F005	R2"	R2"	260	267	329	387	649	714	185	665	951
5SVE04F007	R2"	R2"	260	267	329	387	649	714	185	690	976
5SVE06F011	R2"	R2"	260	267	329	387	649	714	185	740	1026
5SVE08F015	R2"	R2"	260	267	329	387	649	714	185	790	1076
10SVE01F005	R2"1/2	R2"1/2	294	301	356	453	726	830	190	719	1005
10SVE02F007	R2"1/2	R2"1/2	294	301	356	453	726	830	190	719	1005
10SVE02F011	R2"1/2	R2"1/2	294	301	356	453	726	830	190	719	1005
10SVE03F015	R2"1/2	R2"1/2	294	301	356	453	726	830	190	751	1037

Dimensions in mm. ± 10 mm tolerance range.

smb30-sv-f\_b\_td

### SET OF 3 PUMPS SVE..F SERIES SINGLE-PHASE POWER SUPPLY (SMB30.../M2)

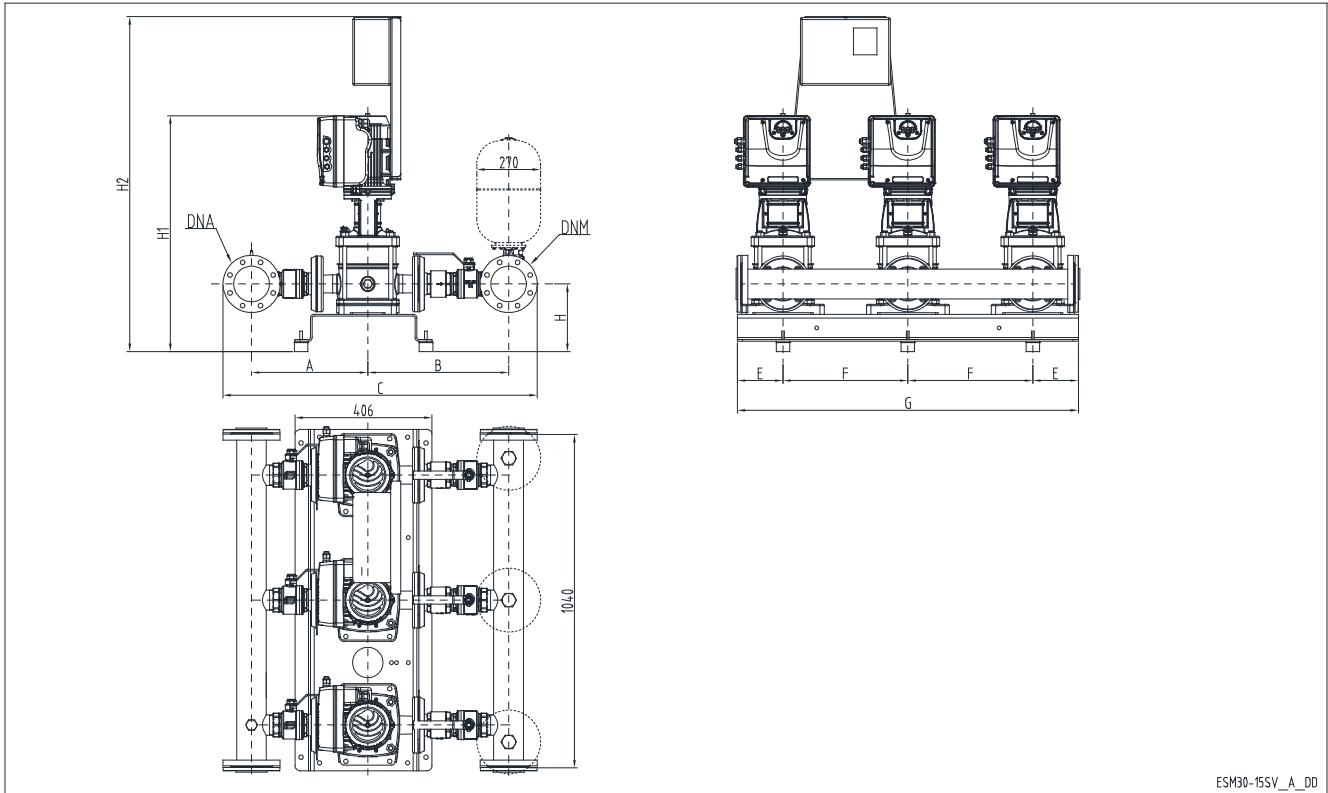

ESM30-15SV\_A\_DD

SMB 30	DNA	DNM	A		B		C		H	H1	H2
			STD	AISI	STD	AISI	STD	AISI			
15SVE01F007	100	80	357	363	418	408	984	981	200	771	1057
15SVE01F011	100	80	357	363	418	408	984	981	200	771	1057
15SVE02F015	100	80	357	363	418	408	984	981	200	771	1057
22SVE01F007	100	100	357	363	430	421	1007	1004	200	771	1057
22SVE01F011	100	100	357	363	430	421	1007	1004	200	771	1057
22SVE02F015	100	100	357	363	430	421	1007	1004	200	771	1057

Dimensions in mm. ± 10 mm tolerance range.

smb30-15sv-f\_a\_td

## SET OF 3 PUMPS SVE..R SERIES SINGLE-PHASE POWER SUPPLY (SMB30.../M2)

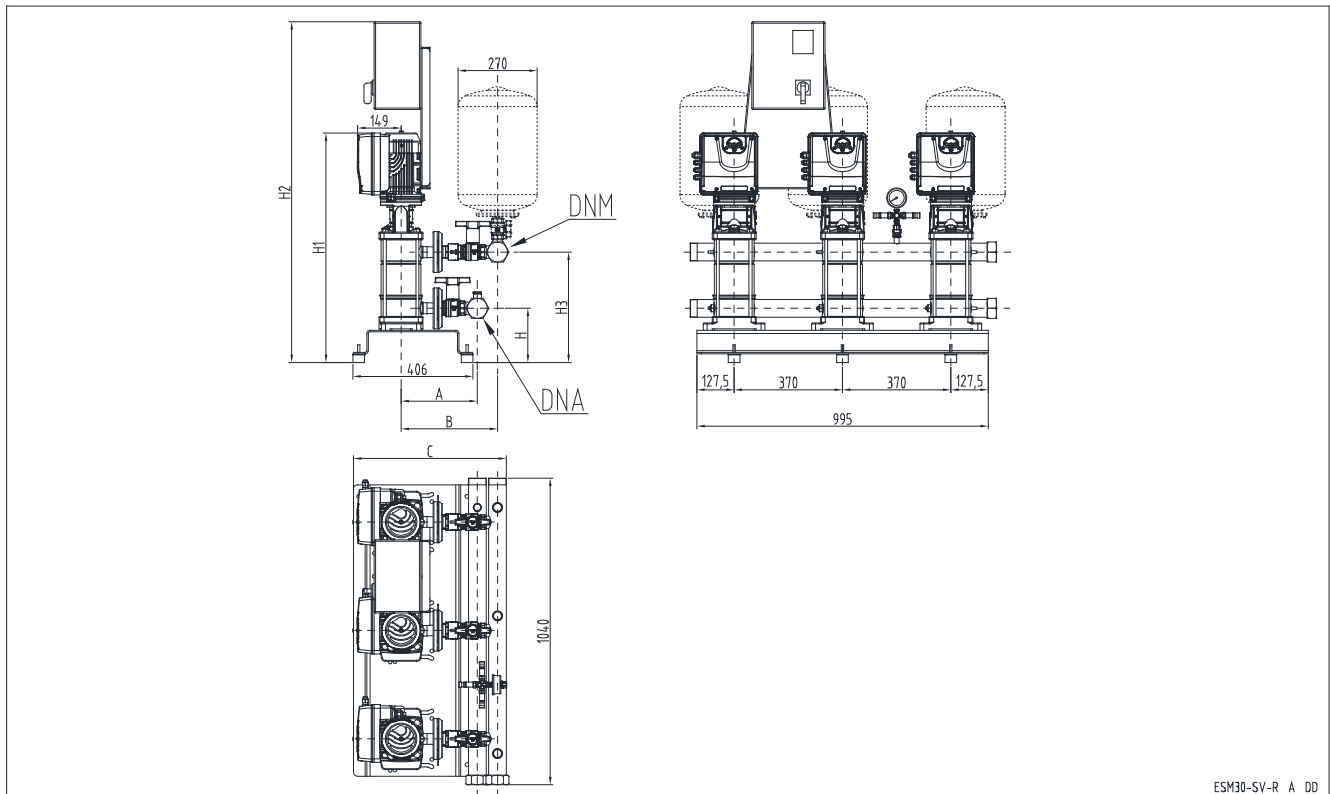

ESM30-SV-R\_A\_DD

SMB 30	DNA	DNM	A		B		C		H	H1	H2	H3
			STD	AISI	STD	AISI	STD	AISI				
1SVE08R005	R2"	R2"	256	257	311	363	490	542	185	750	1036	337
1SVE11R007	R2"	R2"	256	257	311	363	490	542	185	810	1096	397
1SVE15R011	R2"	R2"	256	257	311	363	490	542	185	890	1176	477
3SVE07R007	R2"	R2"	256	257	311	363	490	542	185	730	1016	317
3SVE09R011	R2"	R2"	256	257	311	363	490	542	185	770	1056	357
3SVE11R015	R2"	R2"	256	257	311	363	490	542	185	810	1096	377
5SVE08R015	R2"	R2"	260	267	329	387	508	566	185	790	1076	377

Dimensions in mm. ± 10 mm tolerance range.

smb30-sv-r\_b\_td

## SET OF 3 PUMPS VME SERIES SINGLE-PHASE POWER SUPPLY (SMB30.../M2)

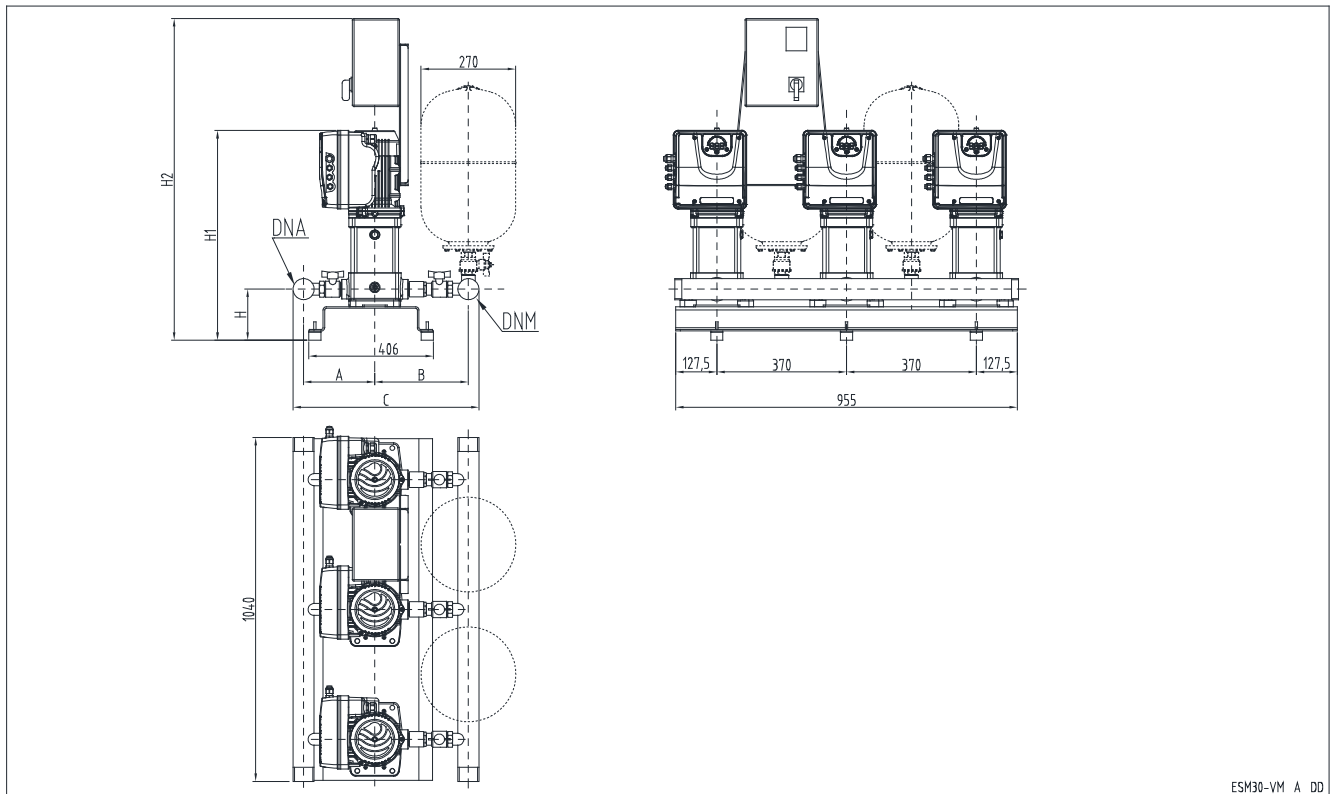

SMB 30	DNA	DNM	A		B		C		H	H1	H2
			STD	AISI	STD	AISI	STD	AISI			
1VME02P03	R2"	R2"	232	314	287	419	579	793	160	525	812
1VME04P05	R2"	R2"	232	314	287	419	579	793	160	545	832
1VME05P07	R2"	R2"	232	314	287	419	579	793	160	565	852
1VME06P11	R2"	R2"	232	314	287	419	579	793	160	585	872
3VME02P03	R2"	R2"	232	314	287	419	579	793	160	525	812
3VME03P05	R2"	R2"	232	314	287	419	579	793	160	525	812
3VME04P07	R2"	R2"	232	314	287	419	579	793	160	545	832
3VME05P11	R2"	R2"	232	314	287	419	579	793	160	545	832
3VME06P15	R2"	R2"	232	314	287	419	579	793	160	585	872
5VME02P05	R2"	R2"	251	329	316	449	627	838	160	525	812
5VME03P07	R2"	R2"	251	329	316	449	627	838	160	525	812
5VME04P11	R2"	R2"	251	329	316	449	627	838	160	545	832
5VME05P15	R2"	R2"	251	329	316	449	627	838	160	545	832
10VME01P07	R2"1/2	R2"1/2	286	374	348	517	710	967	190	589	876
10VME02P11	R2"1/2	R2"1/2	286	374	348	517	710	967	190	589	876

Dimensions in mm. ± 10 mm tolerance range.

smb30-vm\_c\_td

## SET OF 3 PUMPS HME...S SERIES SINGLE-PHASE POWER SUPPLY (SMB30.../M2)

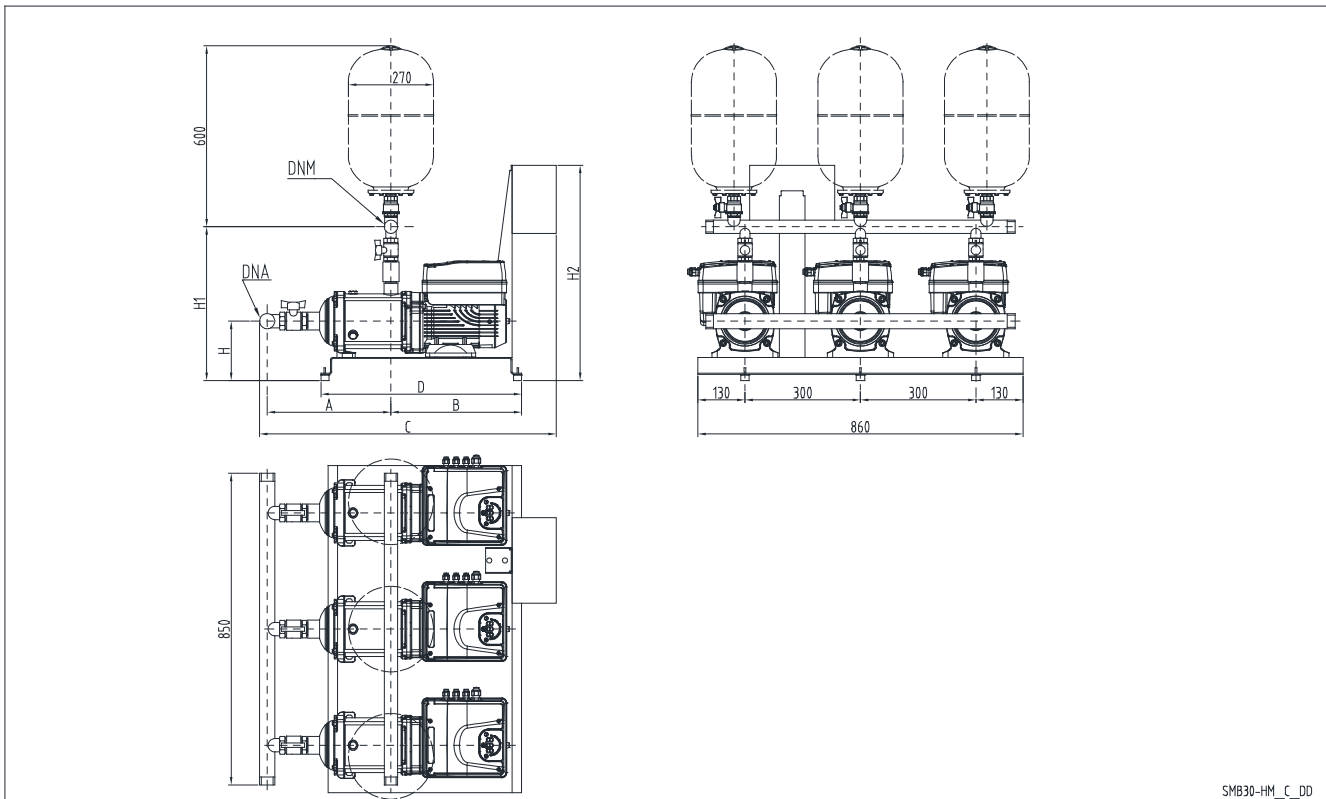

SMB 30	DNA	DNM	A		B	C		D	H	H1		H2
			STD	AISI		STD	AISI			STD	AISI	
1HME05	R 2"	R 2"	264	308	340	694	738	590	205	408	446	720
1HME08	R 2"	R 2"	308	352	349	747	791	590	205	490	528	720
1HME11	R 2"	R 2"	368	412	349	807	851	590	205	490	528	720
1HME15	R 2"	R 2"	448	492	349	887	931	762	205	490	528	720
1HME17	R 2"	R 2"	488	532	349	927	971	762	205	490	528	720
3HME03	R 2"	R 2"	224	268	340	654	698	590	205	408	446	720
3HME05	R 2"	R 2"	264	308	340	694	738	590	205	408	446	720
3HME07	R 2"	R 2"	288	332	349	727	771	590	205	490	528	720
3HME09	R 2"	R 2"	328	372	349	767	811	590	205	490	528	720
3HME12	R 2"	R 2"	388	432	349	827	871	590	205	490	528	720
5HME02	R 2"	R 2"	260	320	340	690	750	590	205	469	543	720
5HME03	R 2"	R 2"	260	320	340	690	750	590	205	469	543	720
5HME04	R 2"	R 2"	285	345	340	715	775	590	205	469	543	720
5HME06	R 2"	R 2"	314	374	349	753	813	590	205	551	625	720
5HME08	R 2"	R 2"	364	424	349	803	863	590	205	551	625	720
10HME01	R 2"1/2	R 2"1/2	301	361	350	749	809	590	205	611	709	720
10HME02	R 2"1/2	R 2"1/2	301	361	350	749	809	590	205	611	709	720
10HME03	R 2"1/2	R 2"1/2	301	361	350	749	809	590	205	611	709	720

Dimensions in mm. ± 10 mm tolerance range.

smb30\_1-10hms\_c\_td

**SET OF 3 PUMPS HME..S SERIES  
SINGLE-PHASE POWER SUPPLY (SMB30.../M2)**

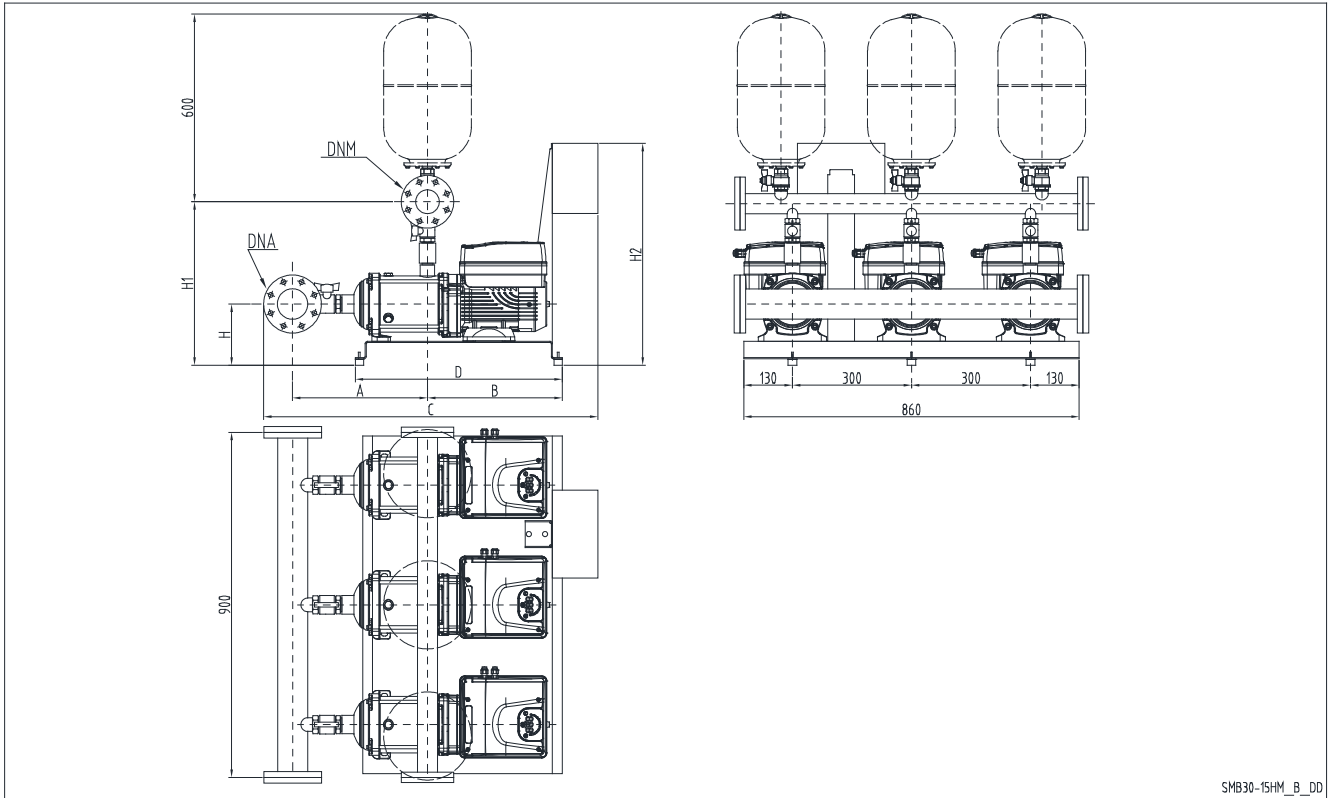

SMB30-15HM\_B\_DD

SMB 30	DNA	DNM	A		B	C		D	H	H1		H2
			STD	AISI		STD	AISI			STD	AISI	
15HME01	DN100	DN80	374	434	366	910	917	590	205	651	704	720
15HME02	DN100	DN80	374	434	366	910	917	590	205	651	704	720

Dimensions in mm. ± 10 mm tolerance range.

smb30\_15hms\_b\_td

## SET OF 3 PUMPS SVE..F SERIES THREE-PHASE POWER SUPPLY (SMB30.../T3-T4)

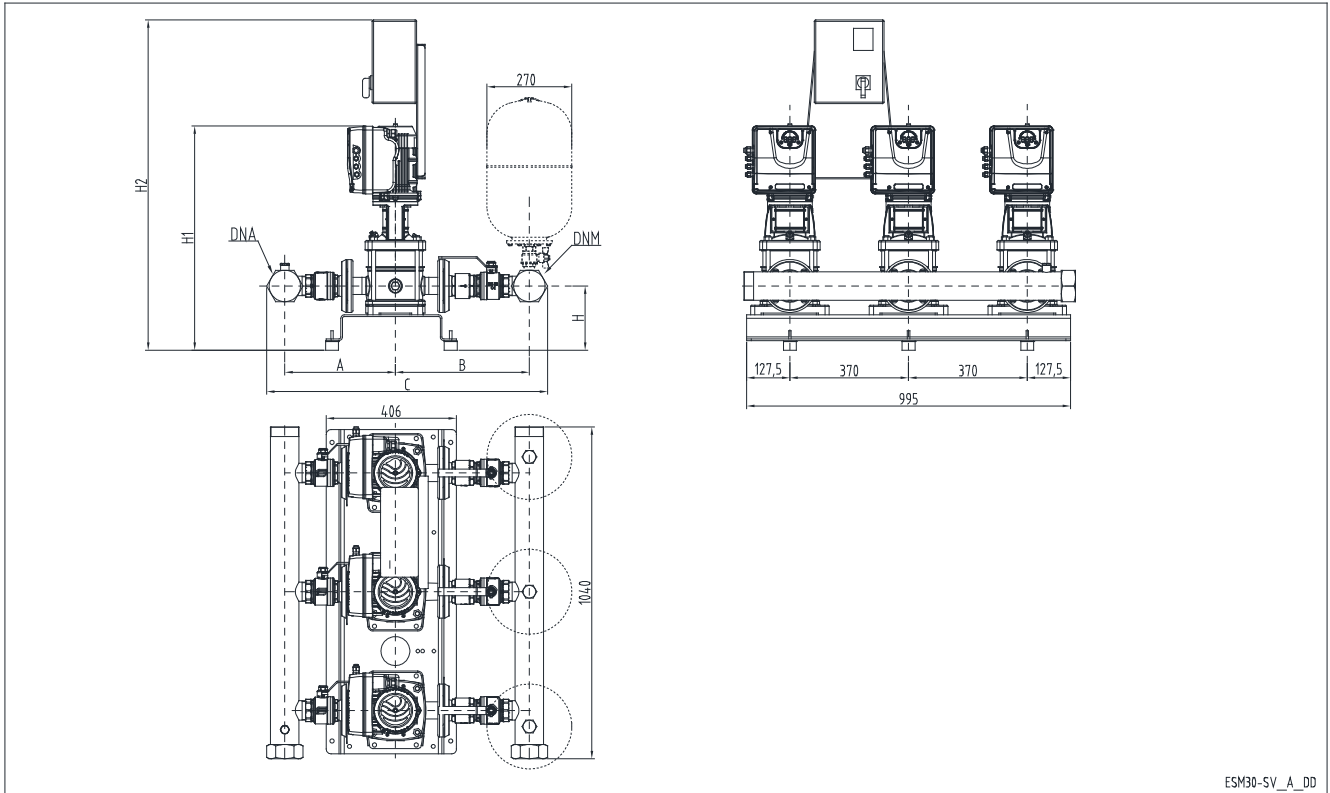

SMB 30	DNA	DNM	A		B		C		H	H1	H2
			STD	AISI	STD	AISI	STD	AISI			
1SVE05F003	R2"	R2"	256	257	311	363	627	680	185	690	976
1SVE08F005	R2"	R2"	256	257	311	363	627	680	185	750	1036
1SVE11F007	R2"	R2"	256	257	311	363	627	680	185	810	1096
1SVE15F011	R2"	R2"	256	257	311	363	627	680	185	890	1176
3SVE03F003	R2"	R2"	256	257	311	363	627	680	185	650	936
3SVE05F005	R2"	R2"	256	257	311	363	627	680	185	690	976
3SVE07F007	R2"	R2"	256	257	311	363	627	680	185	730	1016
3SVE09F011	R2"	R2"	256	257	311	363	627	680	185	770	1056
3SVE11F015	R2"	R2"	256	257	311	363	627	680	185	810	1096
5SVE02F003	R2"	R2"	260	267	329	387	649	714	185	640	926
5SVE03F005	R2"	R2"	260	267	329	387	649	714	185	665	951
5SVE04F007	R2"	R2"	260	267	329	387	649	714	185	690	976
5SVE06F011	R2"	R2"	260	267	329	387	649	714	185	740	1026
5SVE08F015	R2"	R2"	260	267	329	387	649	714	185	790	1076
5SVE12F022	R2"	R2"	260	267	329	387	649	714	185	890	1176
10SVE01F005	R2"1/2	R2"1/2	294	301	356	453	726	830	190	719	1005
10SVE02F007	R2"1/2	R2"1/2	294	301	356	453	726	830	190	719	1005
10SVE02F011	R2"1/2	R2"1/2	294	301	356	453	726	830	190	719	1005
10SVE03F015	R2"1/2	R2"1/2	294	301	356	453	726	830	190	751	1037
10SVE04F022	R2"1/2	R2"1/2	294	301	356	453	726	830	190	783	1069

Dimensions in mm. ± 10 mm tolerance range.

smb30-sv-f-tri\_a\_td

### SET OF 3 PUMPS SVE..F SERIES THREE-PHASE POWER SUPPLY (SMB30.../T3-T4)

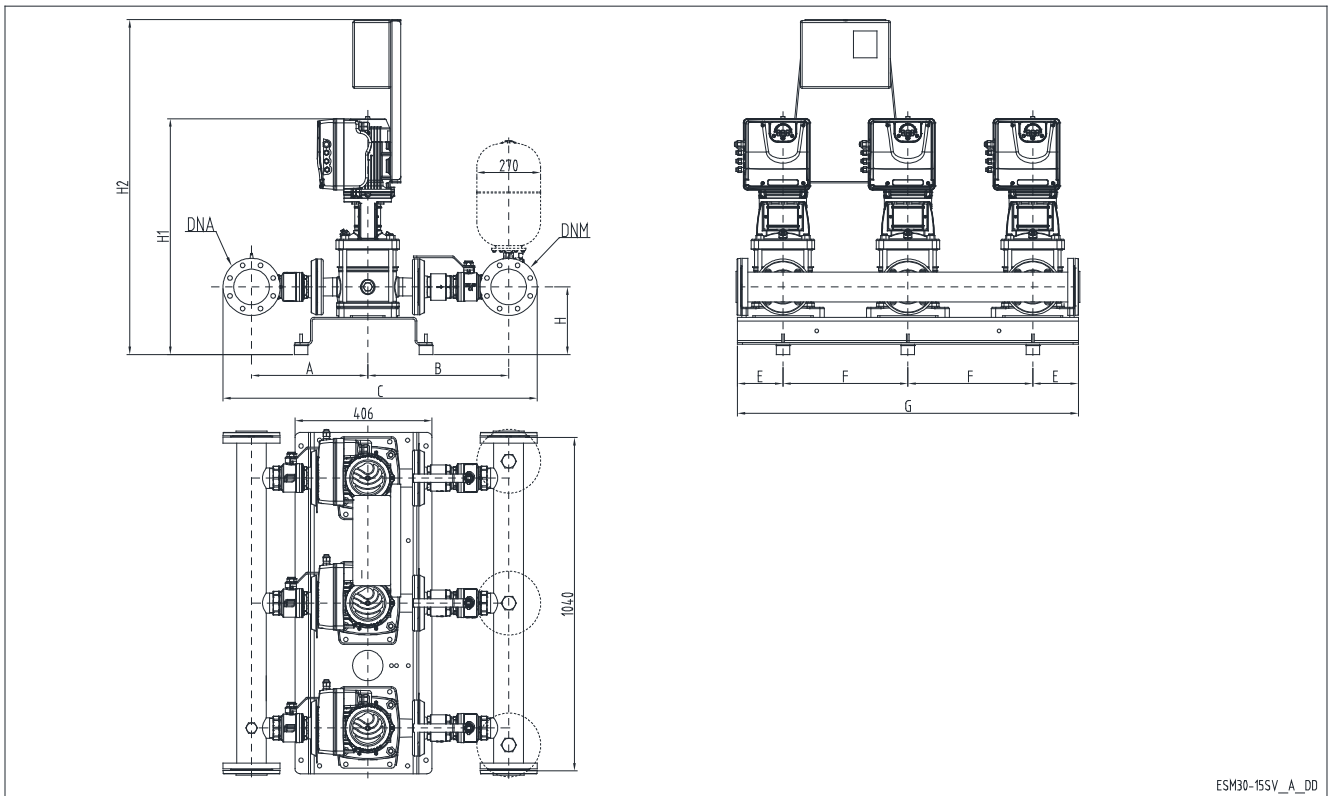

SMB 30	DNA	DNM	A		B		C		H	H1	H2
			STD	AISI	STD	AISI	STD	AISI			
15SVE01F007	100	80	357	363	418	408	984	981	200	771	1057
15SVE01F011	100	80	357	363	418	408	984	981	200	771	1057
15SVE02F015	100	80	357	363	418	408	984	981	200	771	1057
15SVE02F022	100	80	357	363	418	408	984	981	200	771	1057
22SVE01F007	100	80	357	363	418	408	984	981	200	771	1057
22SVE01F011	100	80	357	363	418	408	984	981	200	771	1057
22SVE02F015	100	80	357	363	418	408	984	981	200	771	1057
22SVE02F022	100	80	357	363	418	408	984	981	200	771	1057

Dimensions in mm. ± 10 mm tolerance range.

smb30-15sv-tri-f\_a\_td

## SET OF 3 PUMPS SVE..R SERIES THREE-PHASE POWER SUPPLY (SMB30.../M2)

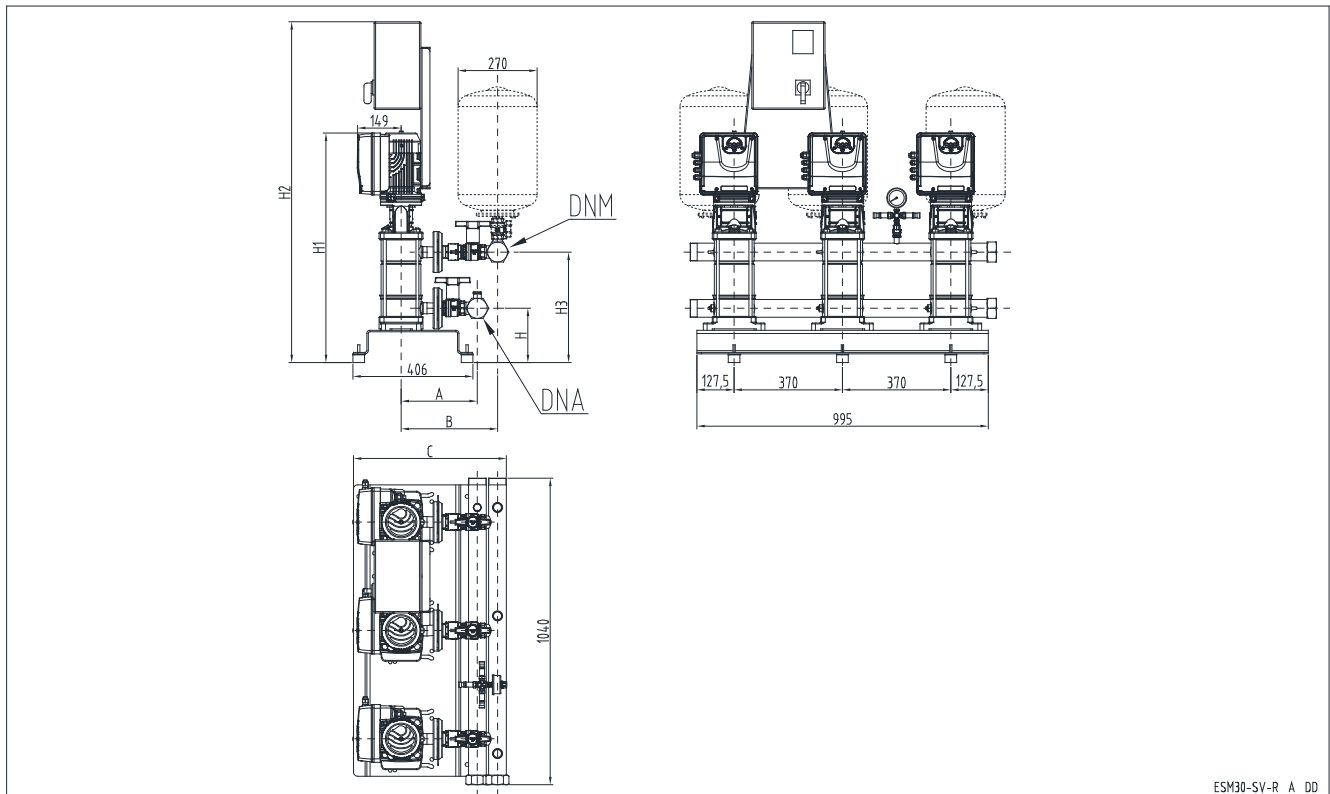

SMB 30	DNA	DNM	A		B		C		H	H1	H2	H3
			STD	AISI	STD	AISI	STD	AISI				
1SVE08R005	R2"	R2"	256	257	311	363	490	542	185	750	1036	337
1SVE11R007	R2"	R2"	256	257	311	363	490	542	185	810	1096	397
1SVE15R011	R2"	R2"	256	257	311	363	490	542	185	890	1176	477
3SVE07R007	R2"	R2"	256	257	311	363	490	542	185	730	1016	317
3SVE09R011	R2"	R2"	256	257	311	363	490	542	185	770	1056	357
3SVE11R015	R2"	R2"	256	257	311	363	490	542	185	810	1096	377
5SVE08R015	R2"	R2"	260	267	329	387	508	566	185	790	1076	377
5SVE12R022	R2"	R2"	260	267	329	387	508	566	185	890	1176	377

Dimensions in mm. ± 10 mm tolerance range.

smb30-sv-r-tri\_a\_td

## SET OF 3 PUMPS VME SERIES THREE-PHASE POWER SUPPLY (SMB30.../T3-T4)

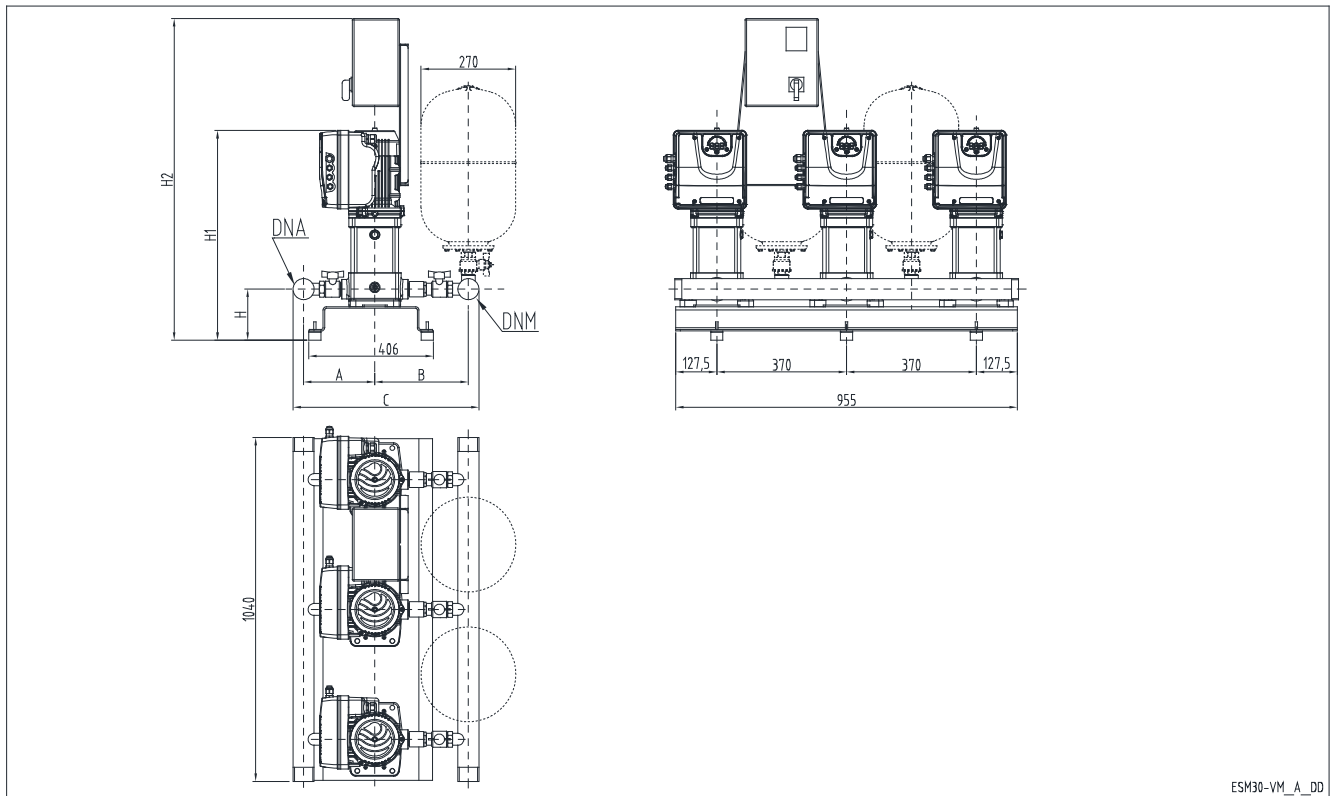

SMB 30	DNA	DNM	A		B		C		H	H1	H2
			STD	AISI	STD	AISI	STD	AISI			
1VME02P03	R2"	R2"	232	314	287	419	579	793	160	525	812
1VME04P05	R2"	R2"	232	314	287	419	579	793	160	545	832
1VME05P07	R2"	R2"	232	314	287	419	579	793	160	565	852
1VME06P11	R2"	R2"	232	314	287	419	579	793	160	585	872
3VME02P03	R2"	R2"	232	314	287	419	579	793	160	525	812
3VME03P05	R2"	R2"	232	314	287	419	579	793	160	525	812
3VME04P07	R2"	R2"	232	314	287	419	579	793	160	545	832
3VME05P11	R2"	R2"	232	314	287	419	579	793	160	545	832
3VME06P15	R2"	R2"	232	314	287	419	579	793	160	585	872
5VME02P05	R2"	R2"	251	329	316	449	627	838	160	525	812
5VME03P07	R2"	R2"	251	329	316	449	627	838	160	525	812
5VME04P11	R2"	R2"	251	329	316	449	627	838	160	545	832
5VME05P15	R2"	R2"	251	329	316	449	627	838	160	565	852
5VME06P22	R2"	R2"	251	329	316	449	627	838	160	585	872
10VME01P07	R2"1/2	R2"1/2	286	374	348	517	710	967	190	589	876
10VME02P11	R2"1/2	R2"1/2	286	374	348	517	710	967	190	589	876

Dimensions in mm. ± 10 mm tolerance range.

smb30-vm-tri\_a\_dd

### SET OF 3 PUMPS HME...S SERIES THREE-PHASE POWER SUPPLY (SMB30.../T3-T4)

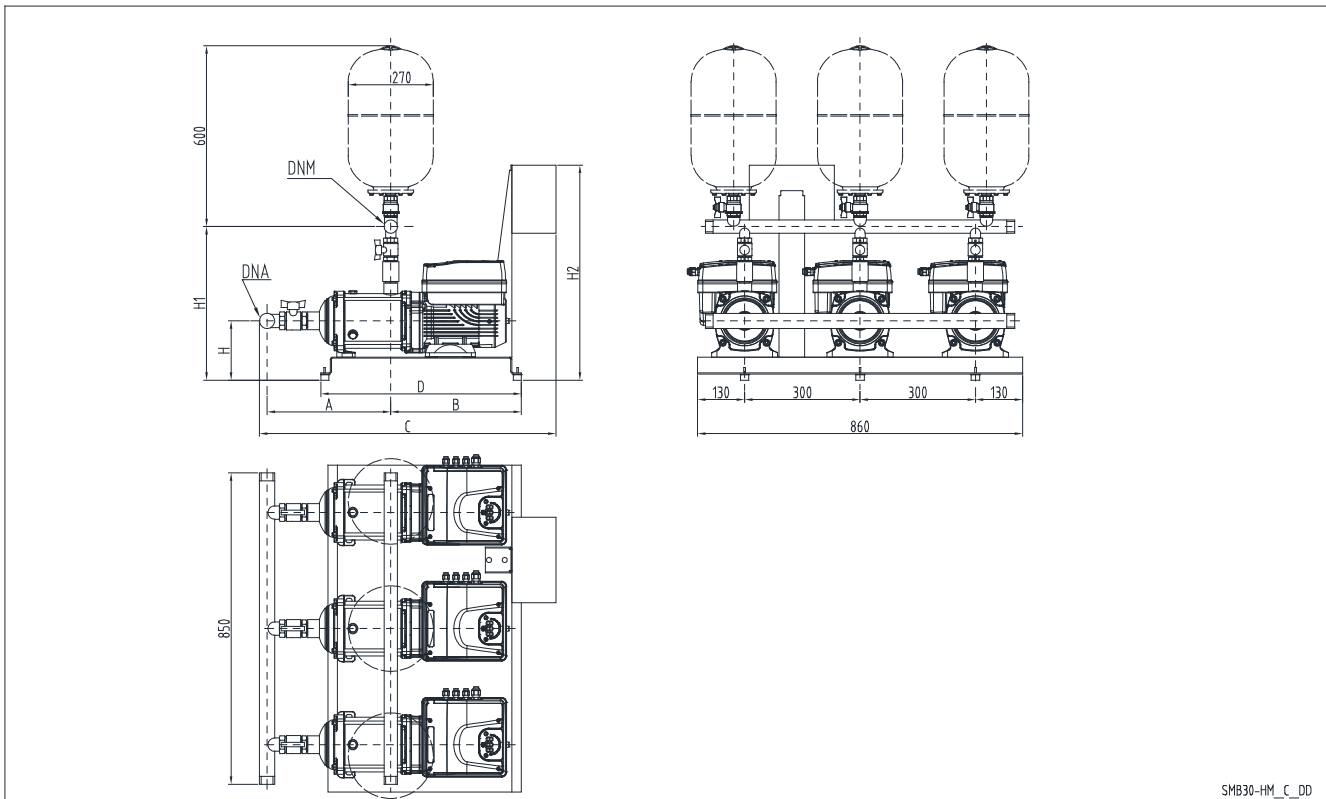

SMB 30	DNA	DNM	A		B	C		D	H	H1		H2
			STD	AISI		STD	AISI			STD	AISI	
1HME05	R 2"	R 2"	264	308	340	722	766	590	205	408	446	829
1HME08	R 2"	R 2"	308	352	349	775	819	590	205	490	528	829
1HME11	R 2"	R 2"	368	412	349	835	879	590	205	490	528	829
1HME15	R 2"	R 2"	448	492	349	915	959	762	205	490	528	829
1HME17	R 2"	R 2"	488	532	349	955	999	762	205	490	528	829
3HME03	R 2"	R 2"	224	268	340	682	726	590	205	408	446	829
3HME05	R 2"	R 2"	264	308	340	722	766	590	205	408	446	829
3HME07	R 2"	R 2"	288	332	349	755	799	590	205	490	528	829
3HME09	R 2"	R 2"	328	372	349	795	839	590	205	490	528	829
3HME12	R 2"	R 2"	388	432	349	855	899	590	205	490	528	829
3HME14	R 2"	R 2"	428	472	349	895	939	590	205	490	528	829
5HME02	R 2"	R 2"	260	320	340	718	778	590	205	469	543	829
5HME03	R 2"	R 2"	260	320	340	718	778	590	205	469	543	829
5HME04	R 2"	R 2"	285	345	340	743	803	590	205	469	543	829
5HME06	R 2"	R 2"	314	374	349	781	841	590	205	551	625	829
5HME08	R 2"	R 2"	364	424	349	831	891	590	205	551	625	829
5HME10	R 2"	R 2"	414	474	349	881	941	590	205	551	625	829
10HME01	R 2"1/2	R 2"1/2	301	361	350	777	837	590	205	611	709	829
10HME02	R 2"1/2	R 2"1/2	301	361	350	777	837	590	205	611	709	829
10HME03	R 2"1/2	R 2"1/2	301	361	350	777	837	590	205	611	709	829
10HME04	R 2"1/2	R 2"1/2	333	393	350	809	869	590	205	611	709	829

Dimensions in mm. ± 10 mm tolerance range.

smb30\_1-10hms-tri\_a\_td

**SET OF 3 PUMPS HME..S SERIES  
THREE-PHASE POWER SUPPLY (SMB30.../T3-T4)**

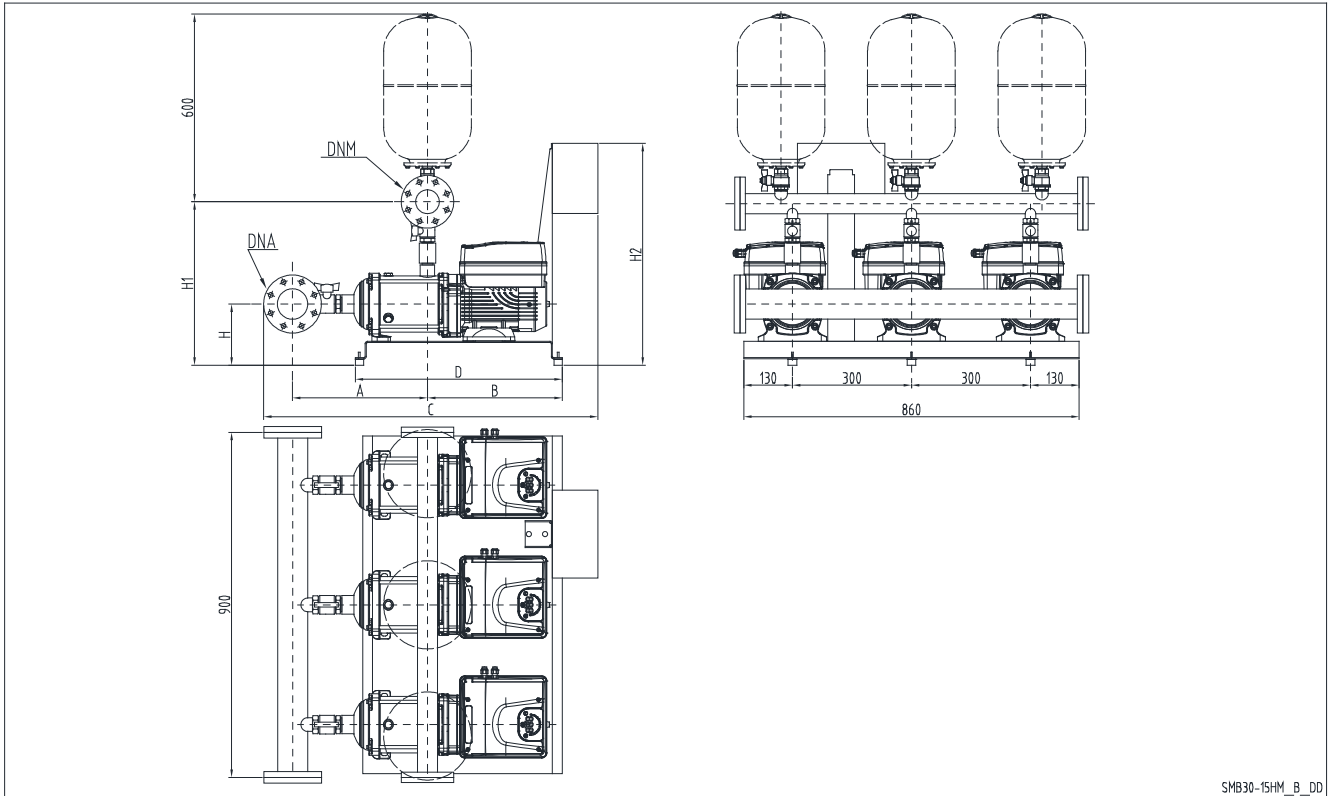

SMB 30	DNA	DNM	A		B	C		D	H	H1		H2
			STD	AISI		STD	AISI			STD	AISI	
15HME01	DN100	DN80	374	434	366	916	988	590	205	651	704	829
15HME02	DN100	DN80	374	434	366	916	988	590	205	651	704	829
15HME03	DN100	DN80	374	434	366	916	988	590	205	651	704	829

Dimensions in mm. ± 10 mm tolerance range.

smb30\_15hms-tri\_a\_td



# PERFORMANCE CURVES

## SMB.../SVE BOOSTER SETS SERIES OPERATING CHARACTERISTICS

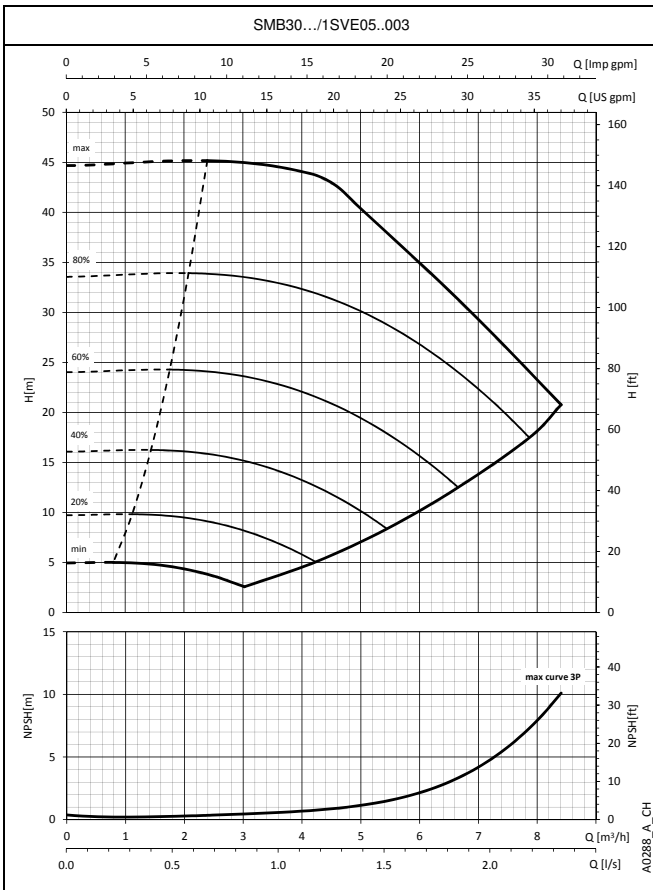
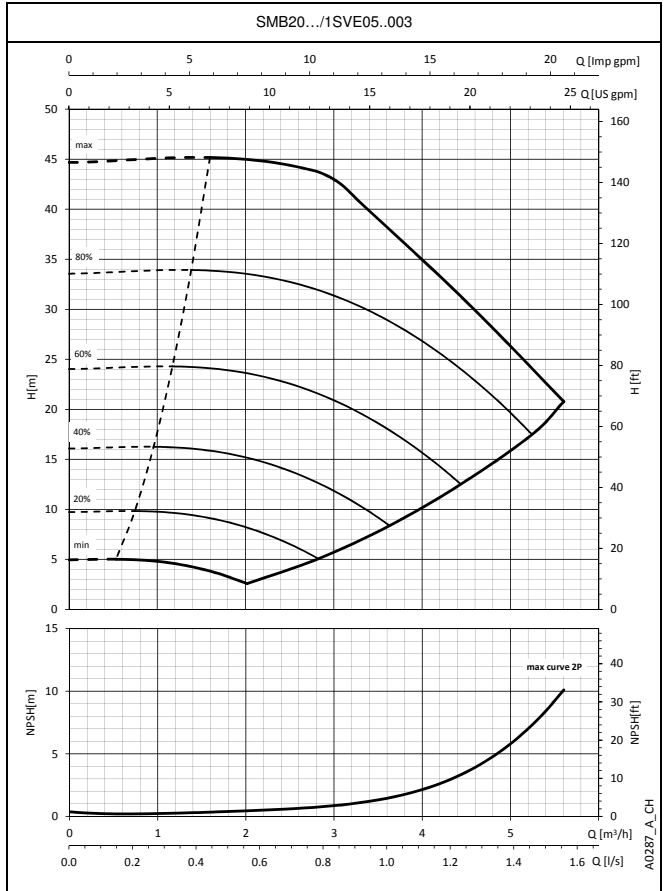
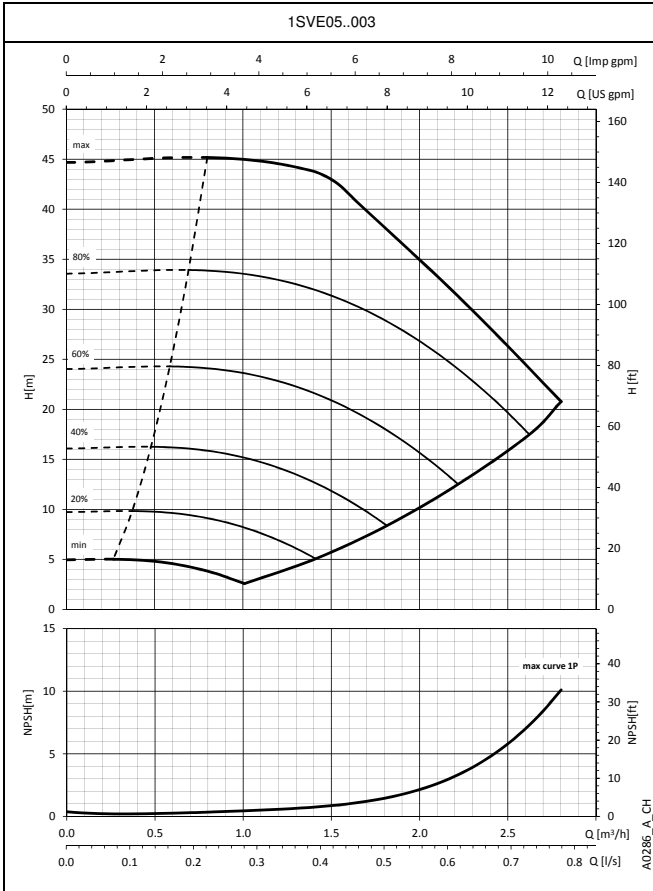

The performance curves do not take into account flow resistance in the valves and piping. The curves show the performance with one, two and three pumps running.  
These performances are valid for liquids with density  $\rho = 1 \text{ Kg/dm}^3$  and kinematic viscosity  $\nu = 1 \text{ mm}^2/\text{sec}$ .  
The declared NPSH values are laboratory values; for practical use we recommend increasing these values by 0,5 m.

## SMB.../SVE BOOSTER SETS SERIES OPERATING CHARACTERISTICS

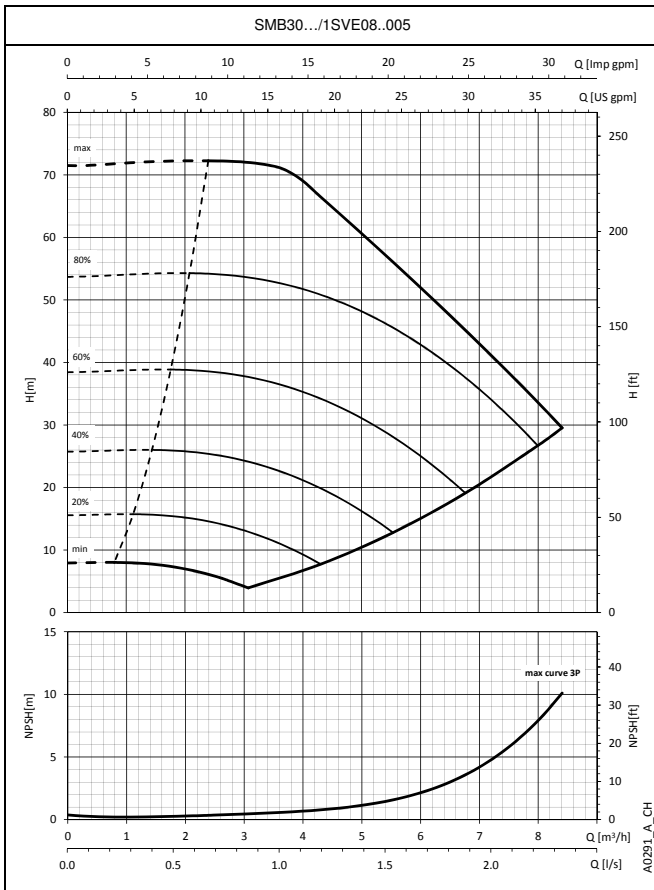
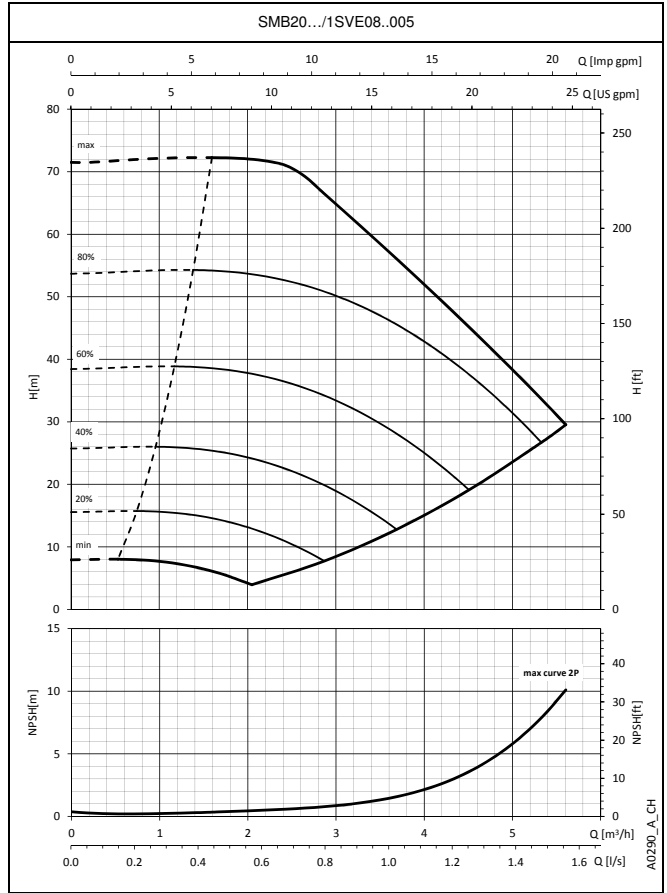
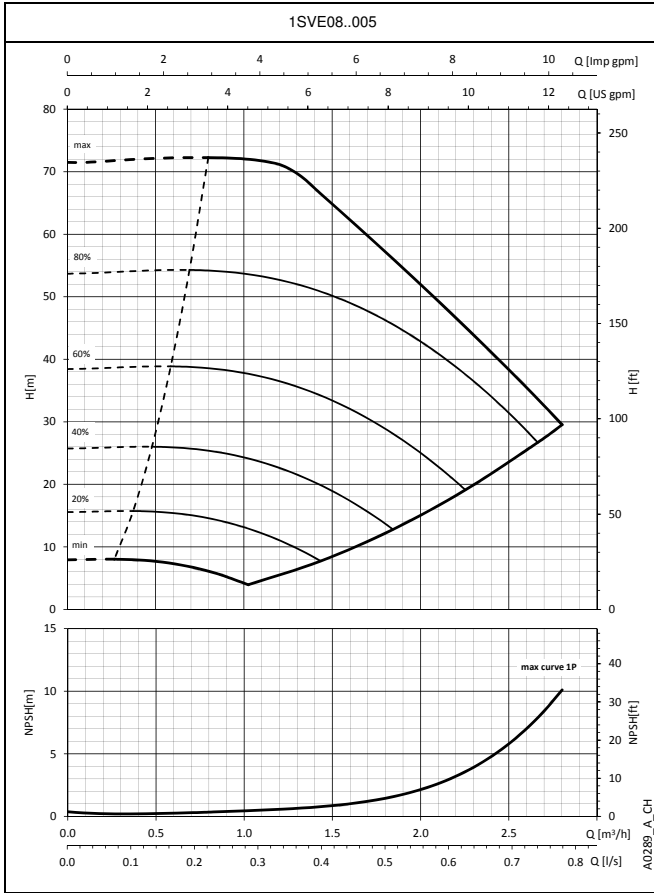

The performance curves do not take into account flow resistance in the valves and piping. The curves show the performance with one, two and three pumps running. These performances are valid for liquids with density  $\rho = 1 \text{ Kg/dm}^3$  and kinematic viscosity  $\nu = 1 \text{ mm}^2/\text{sec}$ . The declared NPSH values are laboratory values; for practical use we recommend increasing these values by 0,5 m.

## SMB.../SVE BOOSTER SETS SERIES OPERATING CHARACTERISTICS

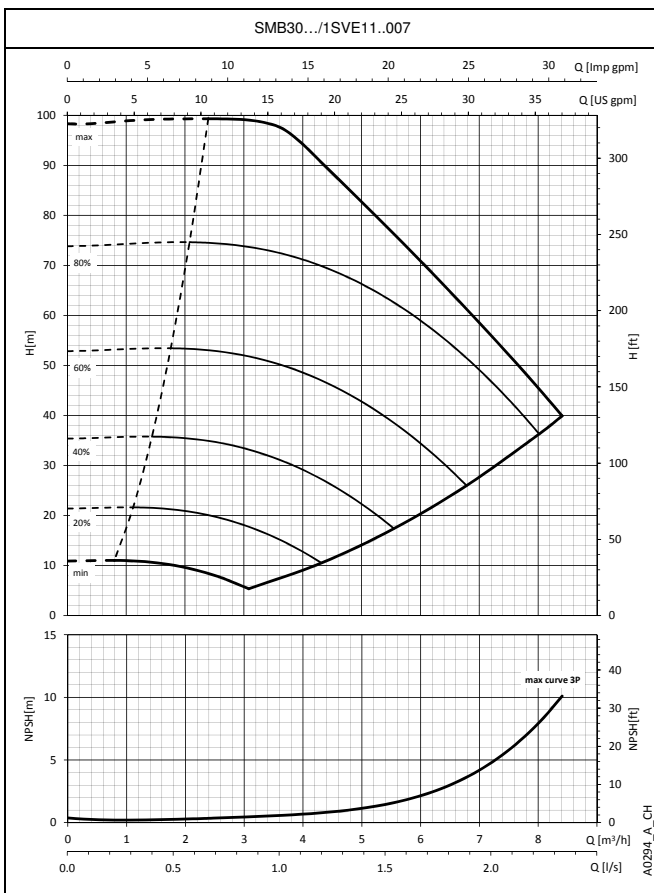
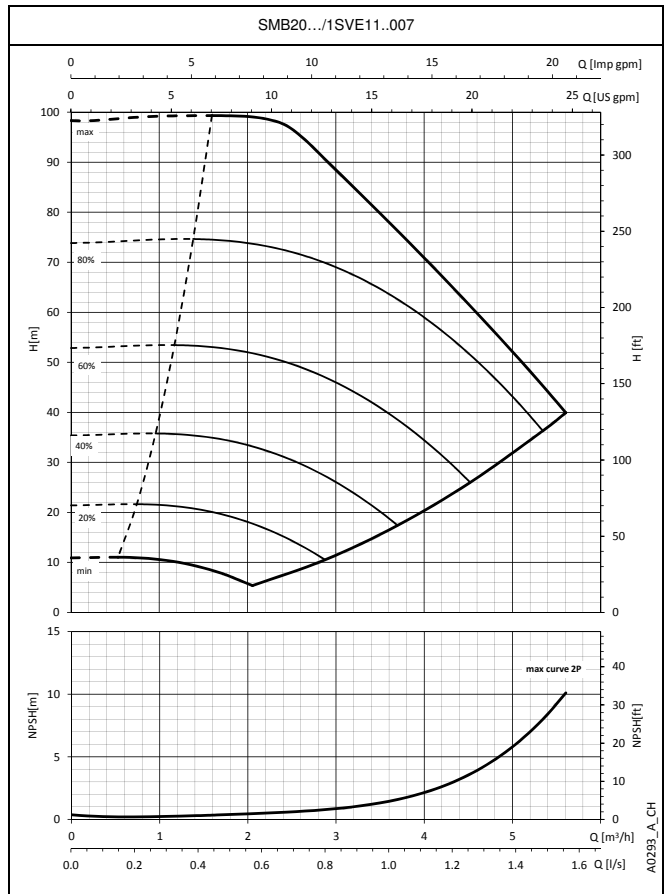
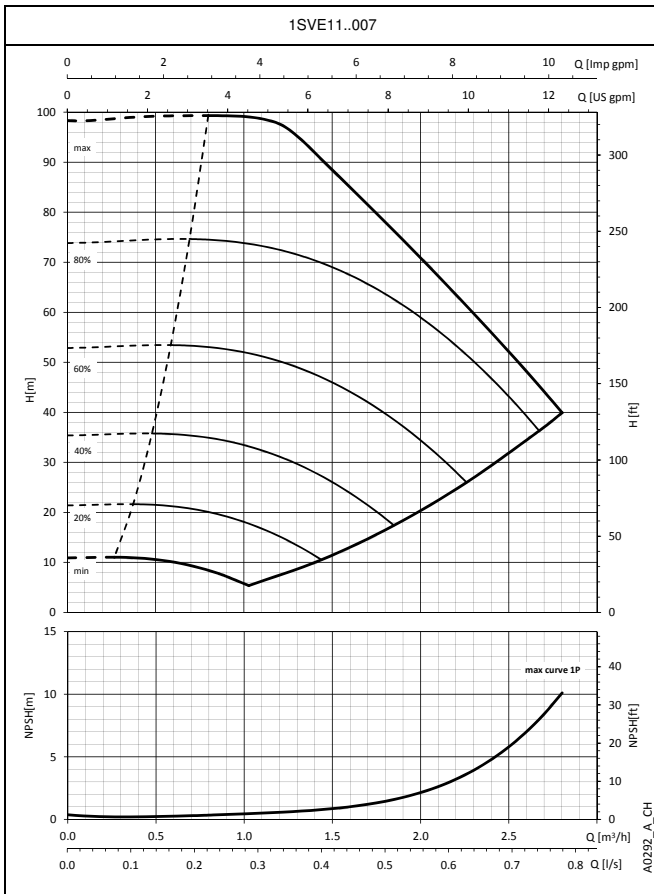

The performance curves do not take into account flow resistance in the valves and piping. The curves show the performance with one, two and three pumps running. These performances are valid for liquids with density  $\rho = 1 \text{ Kg/dm}^3$  and kinematic viscosity  $\nu = 1 \text{ mm}^2/\text{sec}$ . The declared NPSH values are laboratory values; for practical use we recommend increasing these values by 0,5 m.

## SMB.../SVE BOOSTER SETS SERIES OPERATING CHARACTERISTICS

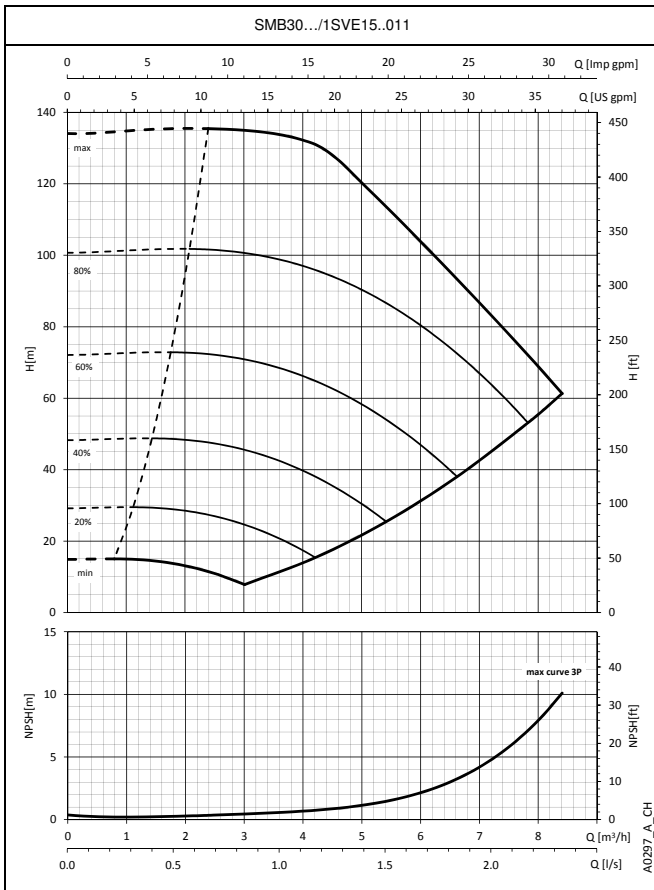
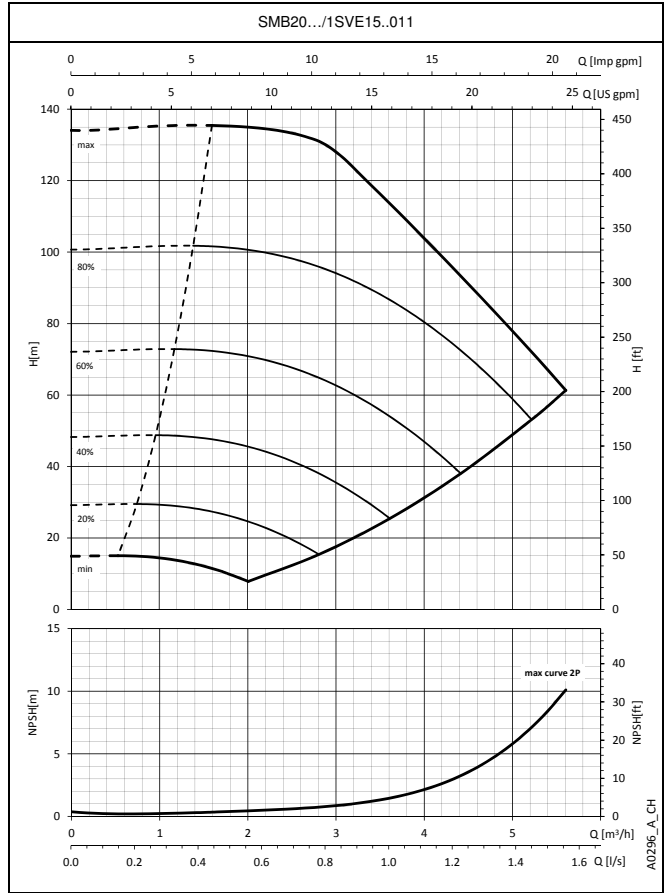
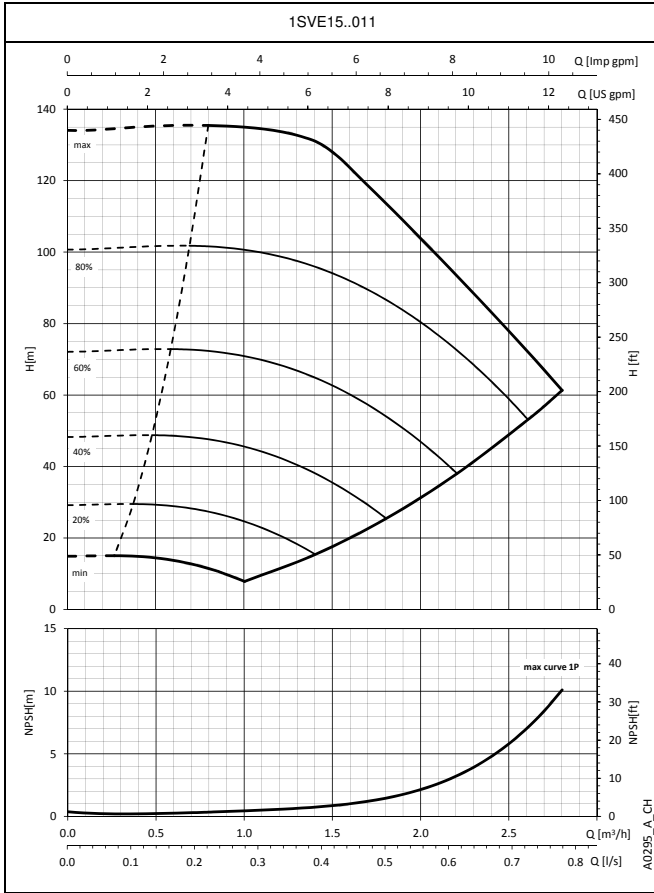

The performance curves do not take into account flow resistance in the valves and piping. The curves show the performance with one, two and three pumps running. These performances are valid for liquids with density  $\rho = 1 \text{ Kg/dm}^3$  and kinematic viscosity  $\nu = 1 \text{ mm}^2/\text{sec}$ . The declared NPSH values are laboratory values; for practical use we recommend increasing these values by 0,5 m.

## SMB.../SVE BOOSTER SETS SERIES OPERATING CHARACTERISTICS

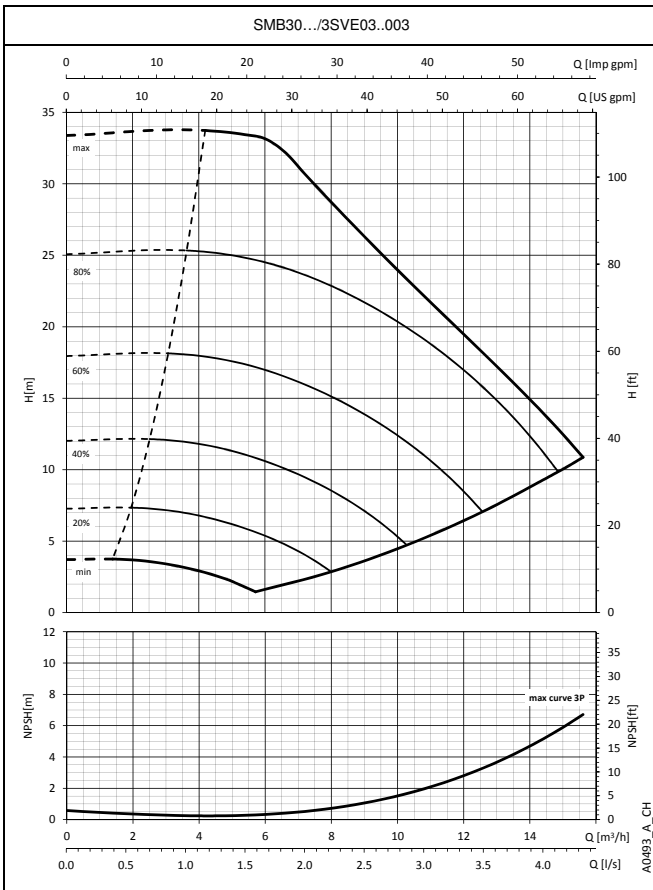
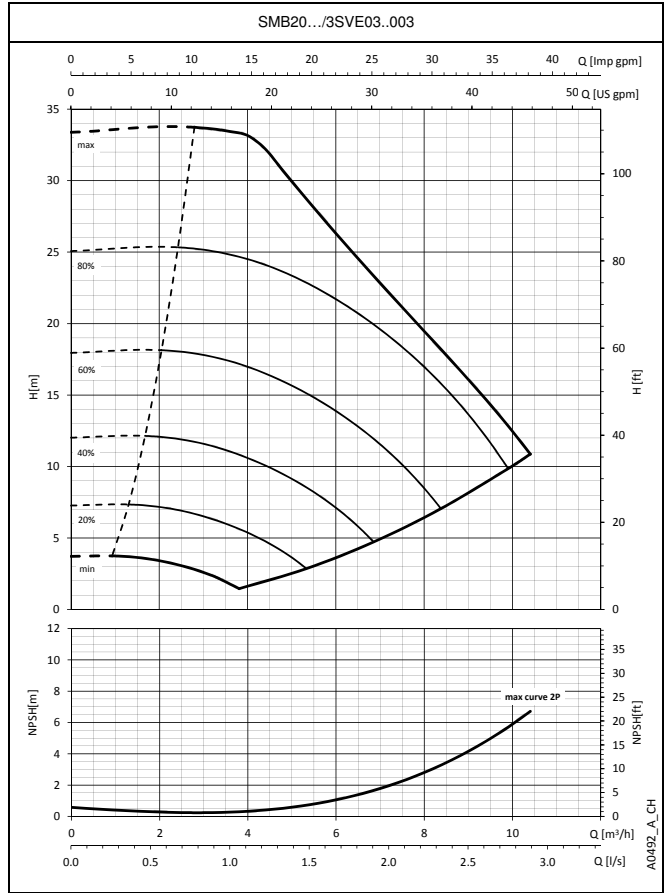
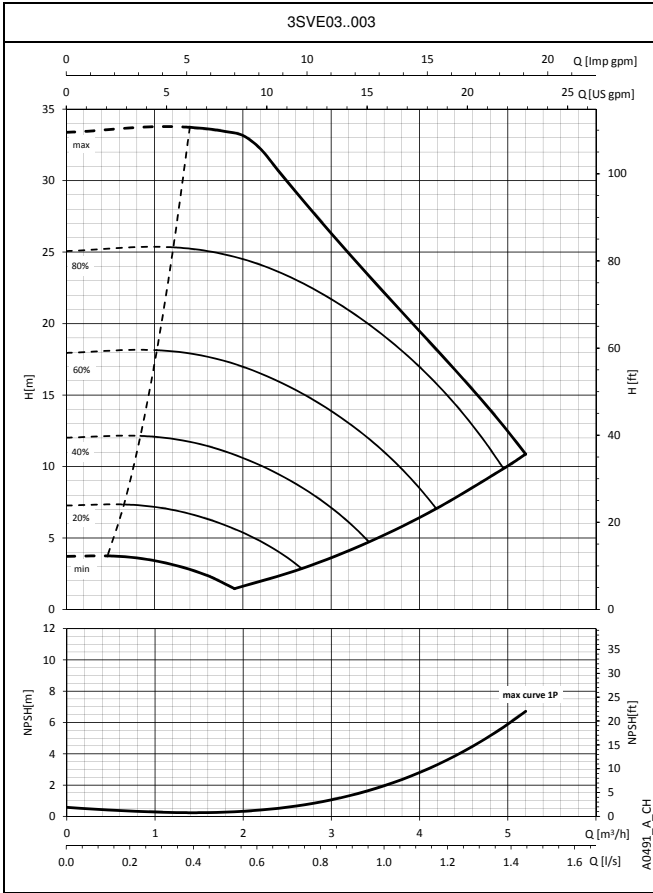

The performance curves do not take into account flow resistance in the valves and piping. The curves show the performance with one, two and three pumps running. These performances are valid for liquids with density  $\rho = 1 \text{ Kg/dm}^3$  and kinematic viscosity  $\nu = 1 \text{ mm}^2/\text{sec}$ . The declared NPSH values are laboratory values; for practical use we recommend increasing these values by 0,5 m.

**SMB.../SVE BOOSTER SETS SERIES  
OPERATING CHARACTERISTICS**

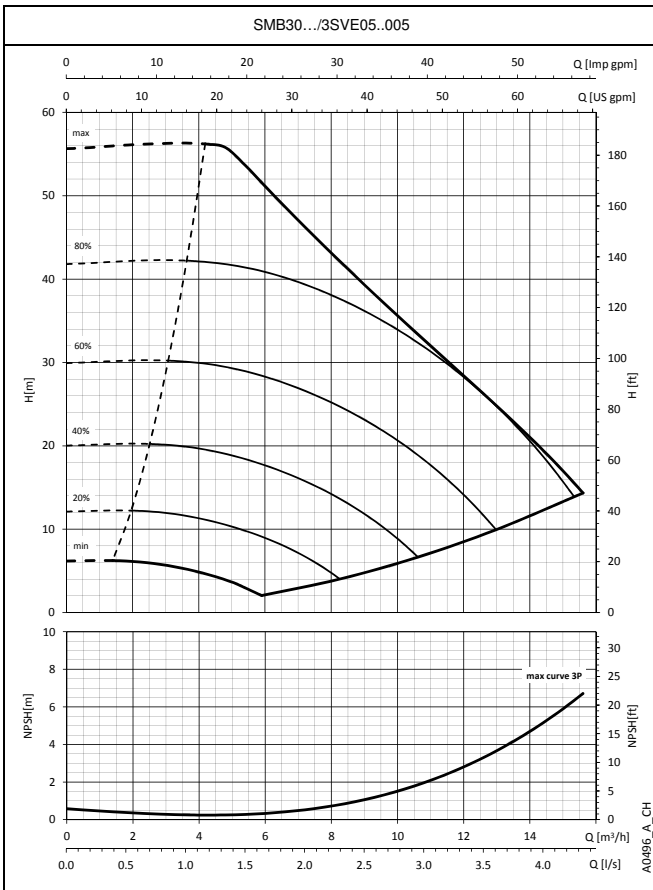
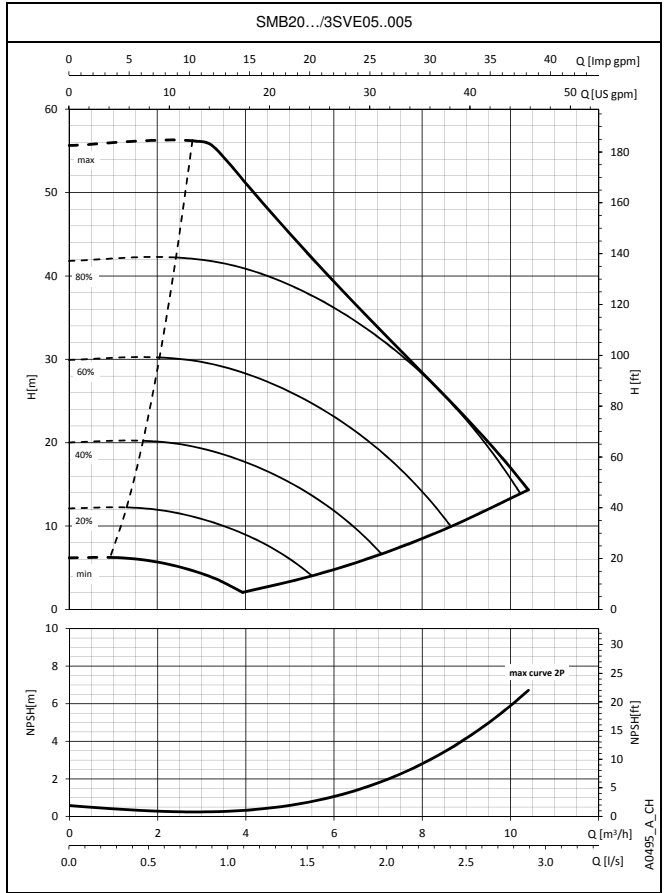
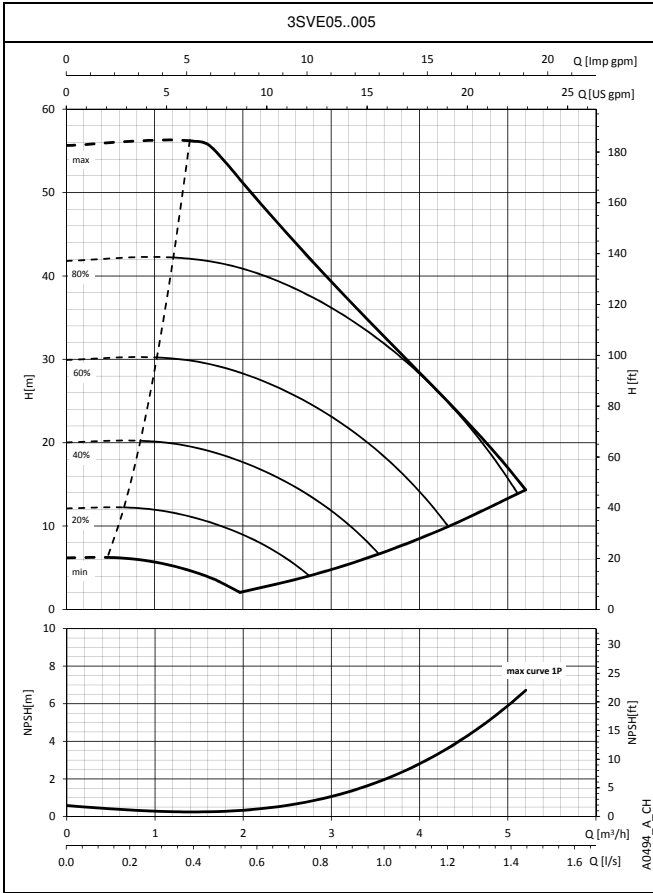

The performance curves do not take into account flow resistance in the valves and piping. The curves show the performance with one, two and three pumps running. These performances are valid for liquids with density  $\rho = 1 \text{ Kg/dm}^3$  and kinematic viscosity  $\nu = 1 \text{ mm}^2/\text{sec}$ . The declared NPSH values are laboratory values; for practical use we recommend increasing these values by 0,5 m.

## SMB.../SVE BOOSTER SETS SERIES OPERATING CHARACTERISTICS

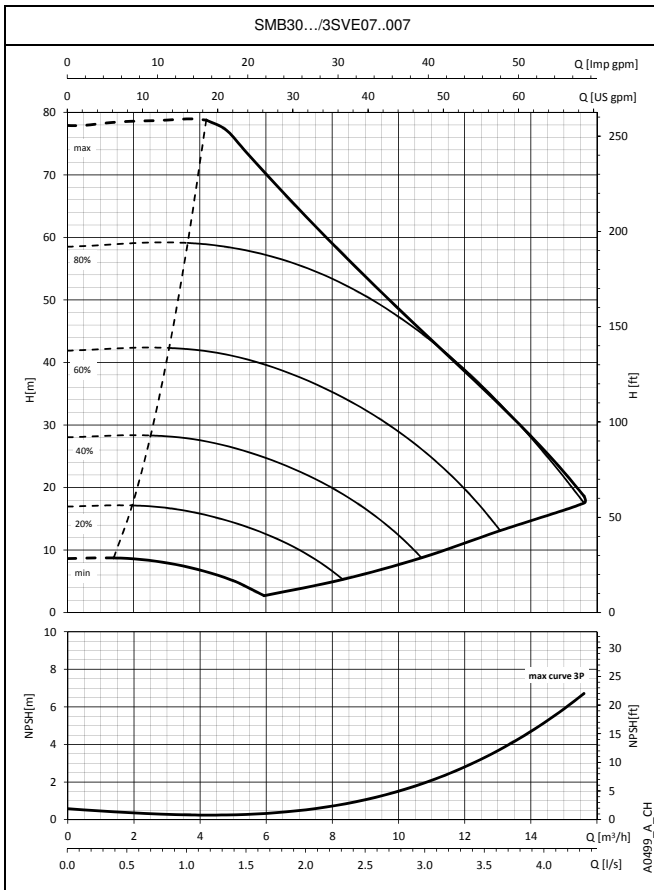
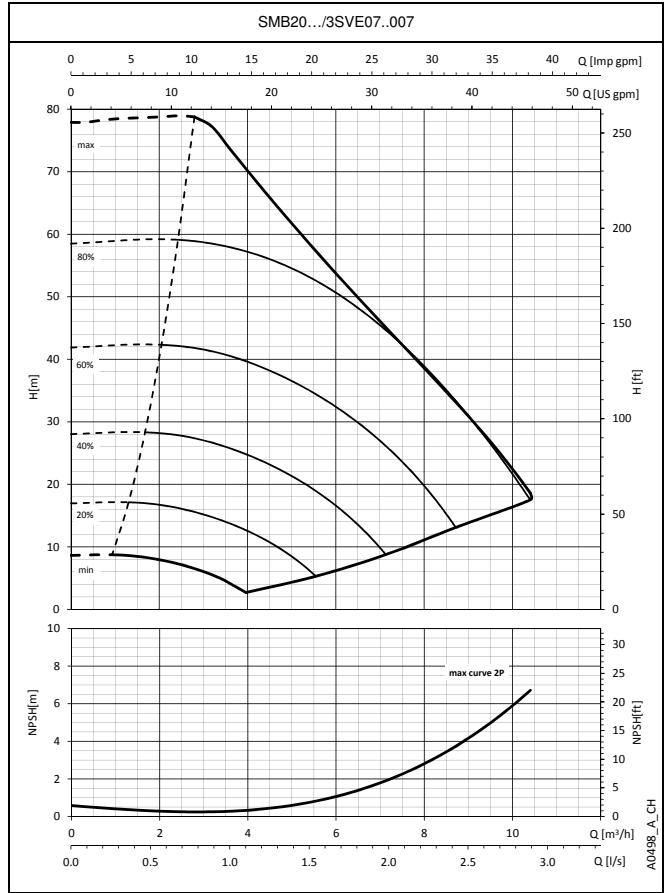
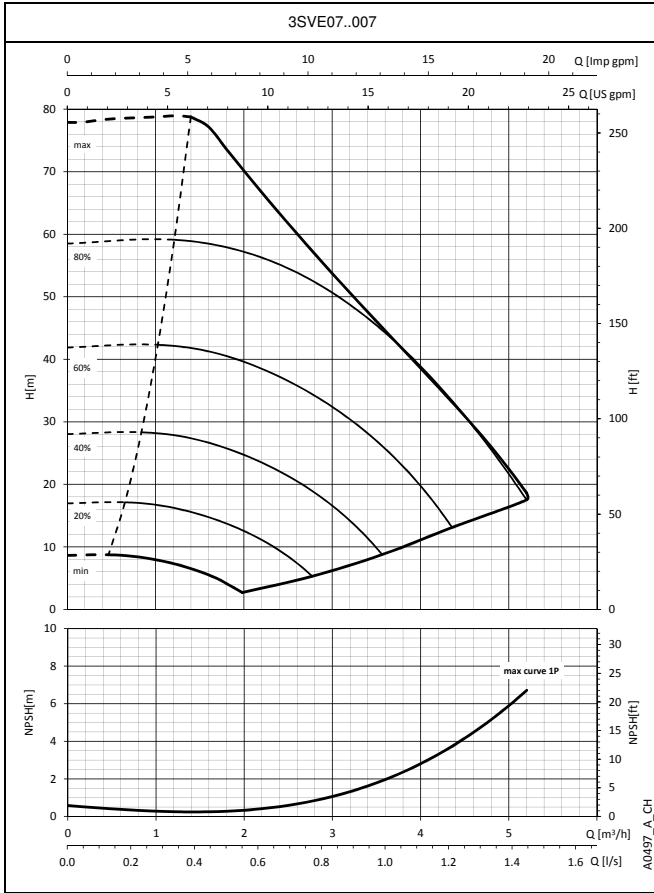

The performance curves do not take into account flow resistance in the valves and piping. The curves show the performance with one, two and three pumps running. These performances are valid for liquids with density  $\rho = 1 \text{ Kg/dm}^3$  and kinematic viscosity  $\nu = 1 \text{ mm}^2/\text{sec}$ . The declared NPSH values are laboratory values; for practical use we recommend increasing these values by 0,5 m.

# SMB.../SVE BOOSTER SETS SERIES OPERATING CHARACTERISTICS

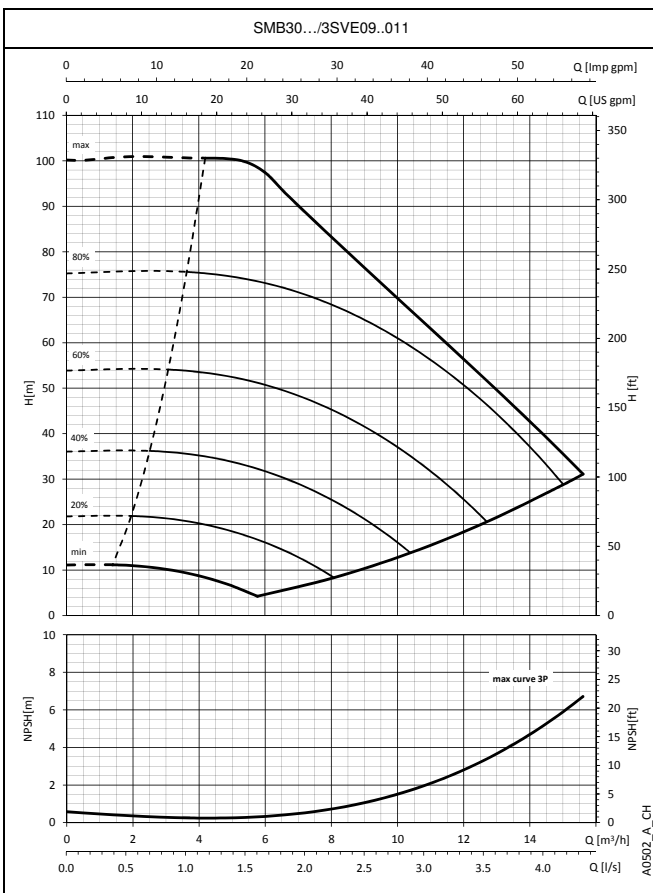
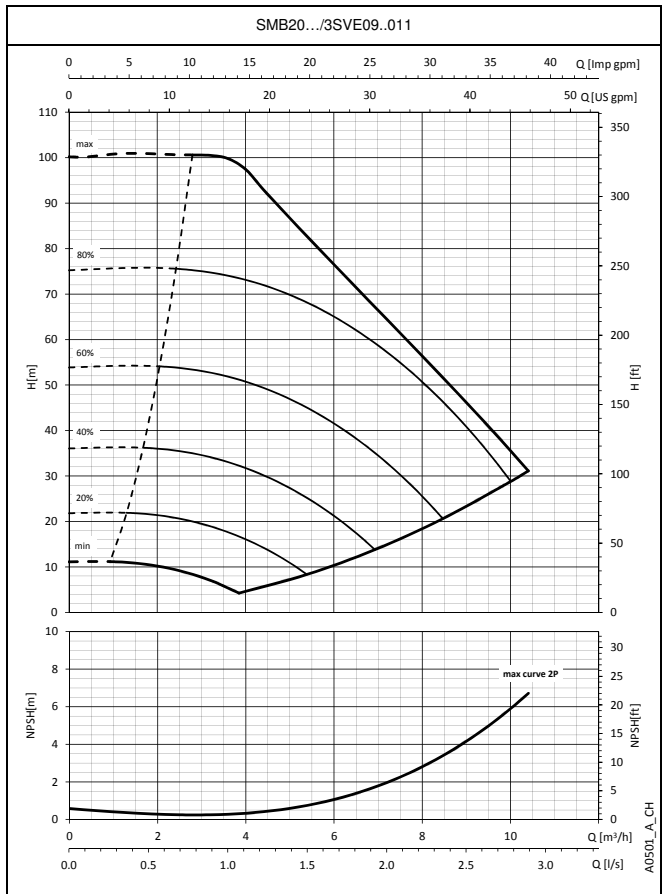
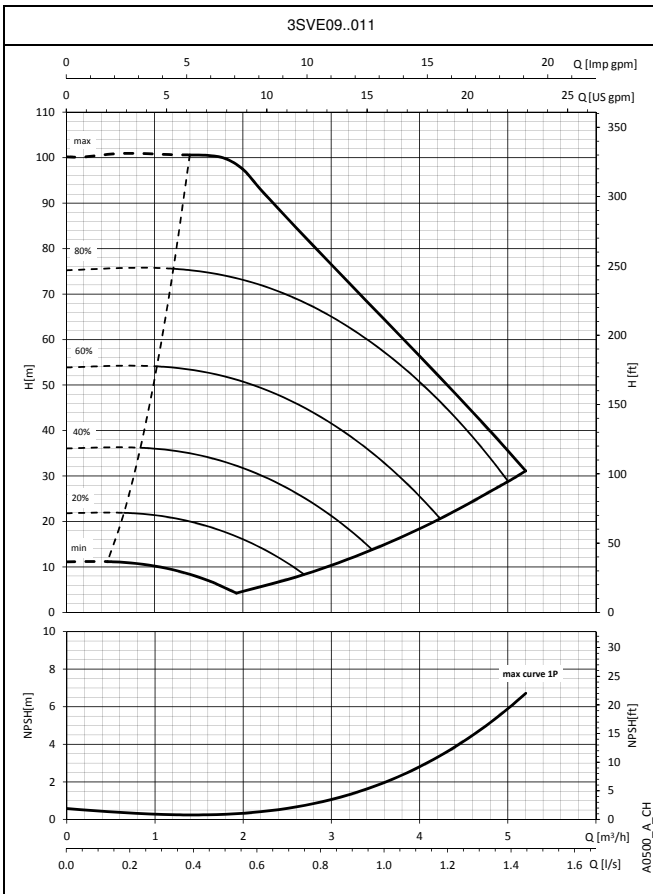

The performance curves do not take into account flow resistance in the valves and piping. The curves show the performance with one, two and three pumps running. These performances are valid for liquids with density  $\rho = 1 \text{ Kg/dm}^3$  and kinematic viscosity  $\nu = 1 \text{ mm}^2/\text{sec}$ . The declared NPSH values are laboratory values; for practical use we recommend increasing these values by 0,5 m.

## SMB.../SVE BOOSTER SETS SERIES OPERATING CHARACTERISTICS

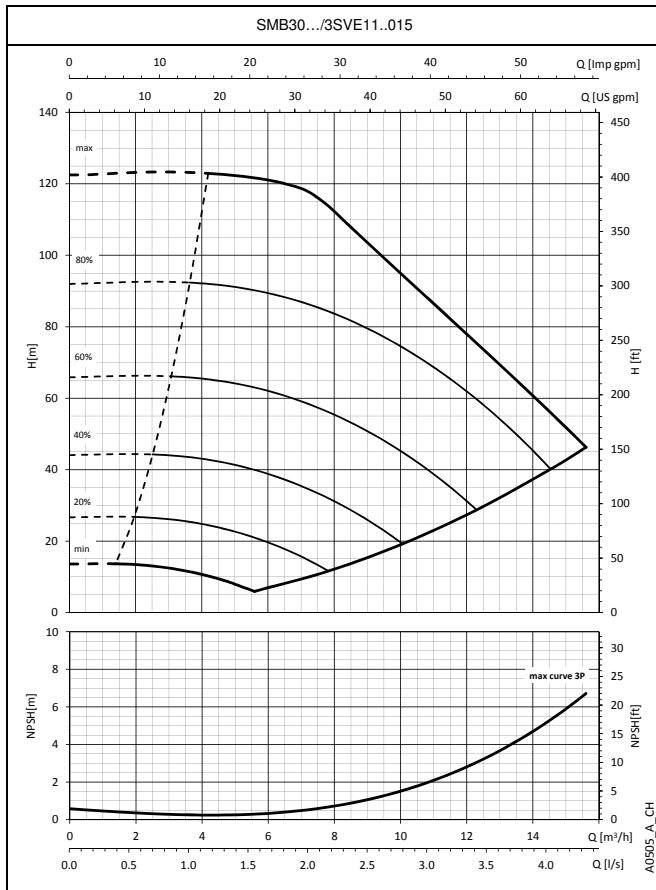
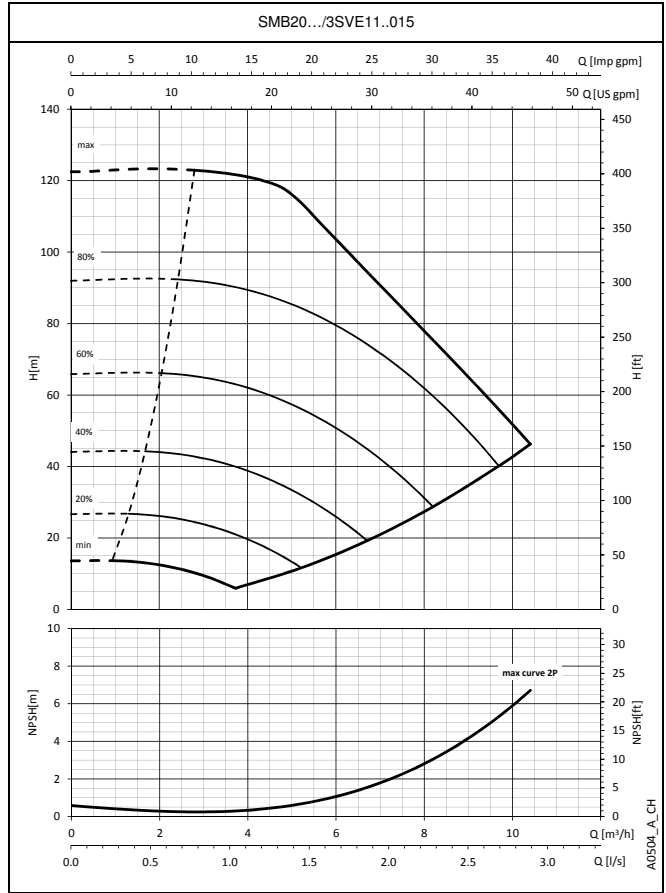
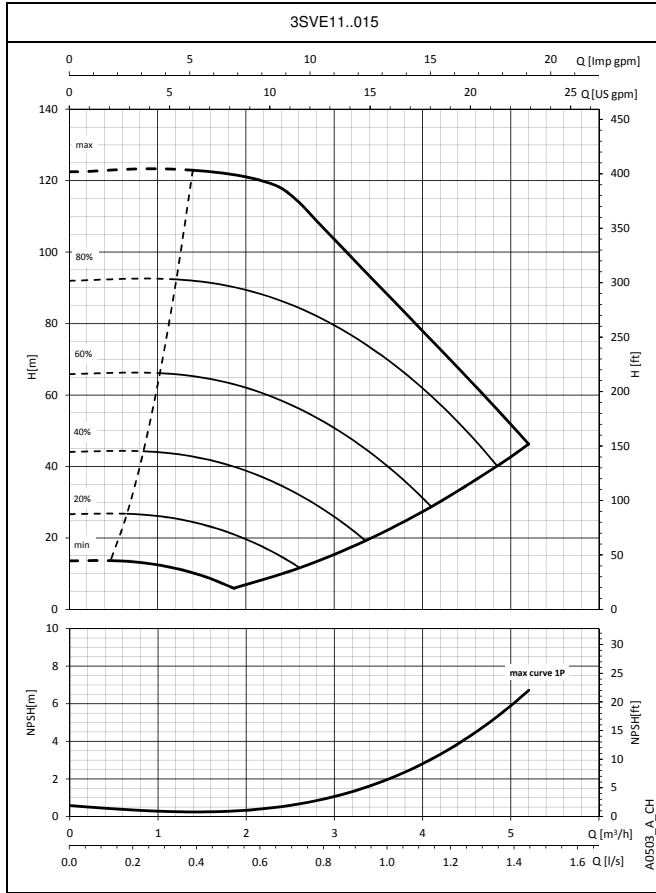

The performance curves do not take into account flow resistance in the valves and piping. The curves show the performance with one, two and three pumps running. These performances are valid for liquids with density  $\rho = 1 \text{ Kg/dm}^3$  and kinematic viscosity  $\nu = 1 \text{ mm}^2/\text{sec}$ . The declared NPSH values are laboratory values; for practical use we recommend increasing these values by 0,5 m.

## SMB.../SVE BOOSTER SETS SERIES OPERATING CHARACTERISTICS

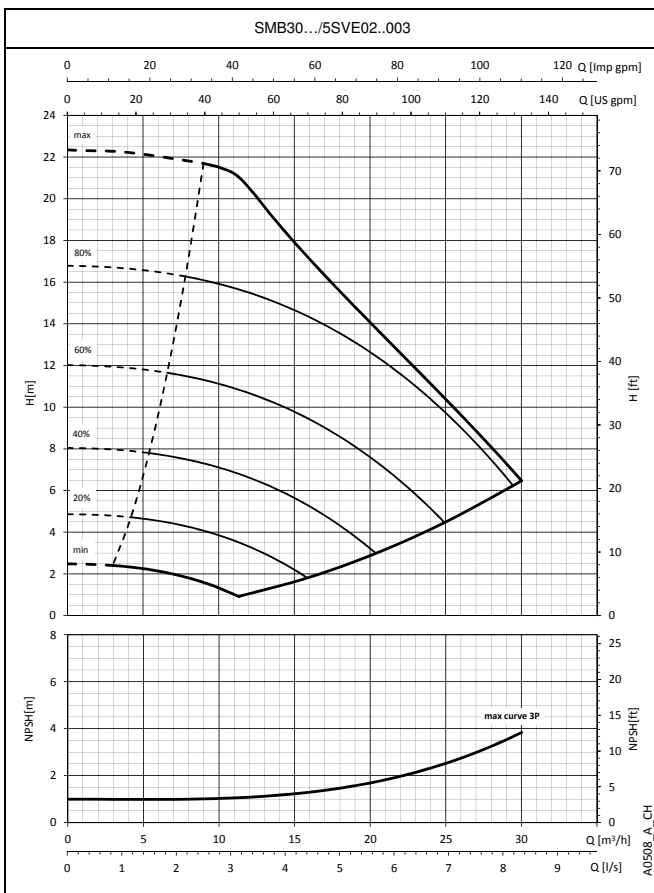
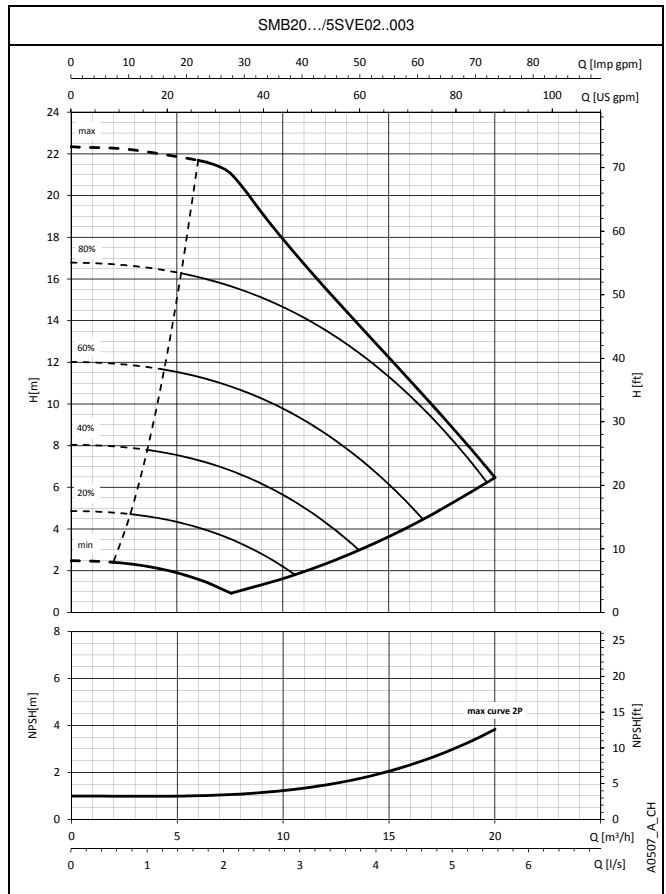
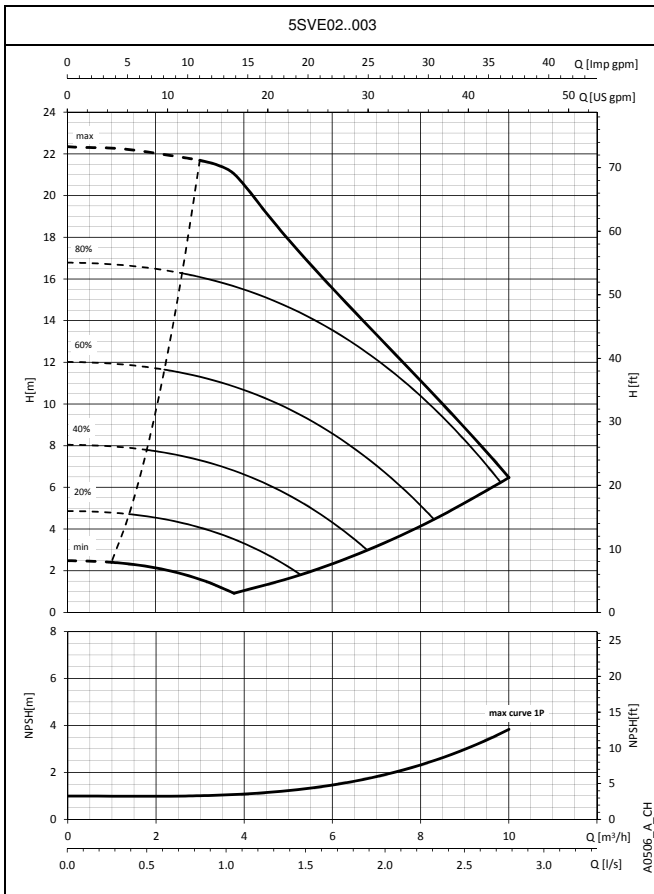

The performance curves do not take into account flow resistance in the valves and piping. The curves show the performance with one, two and three pumps running. These performances are valid for liquids with density  $\rho = 1 \text{ Kg/dm}^3$  and kinematic viscosity  $\nu = 1 \text{ mm}^2/\text{sec}$ . The declared NPSH values are laboratory values; for practical use we recommend increasing these values by 0,5 m.

**SMB.../SVE BOOSTER SETS SERIES  
OPERATING CHARACTERISTICS**

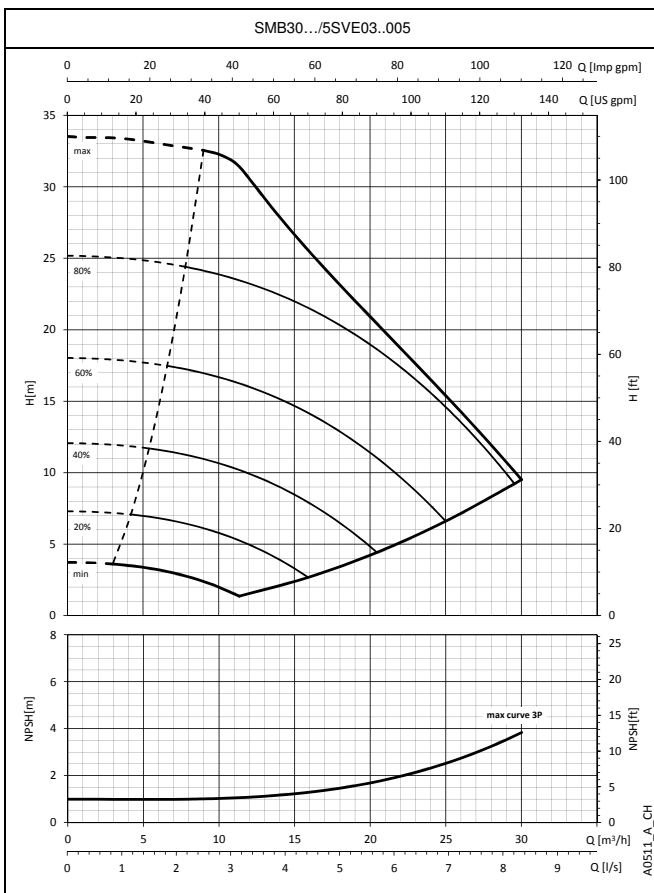
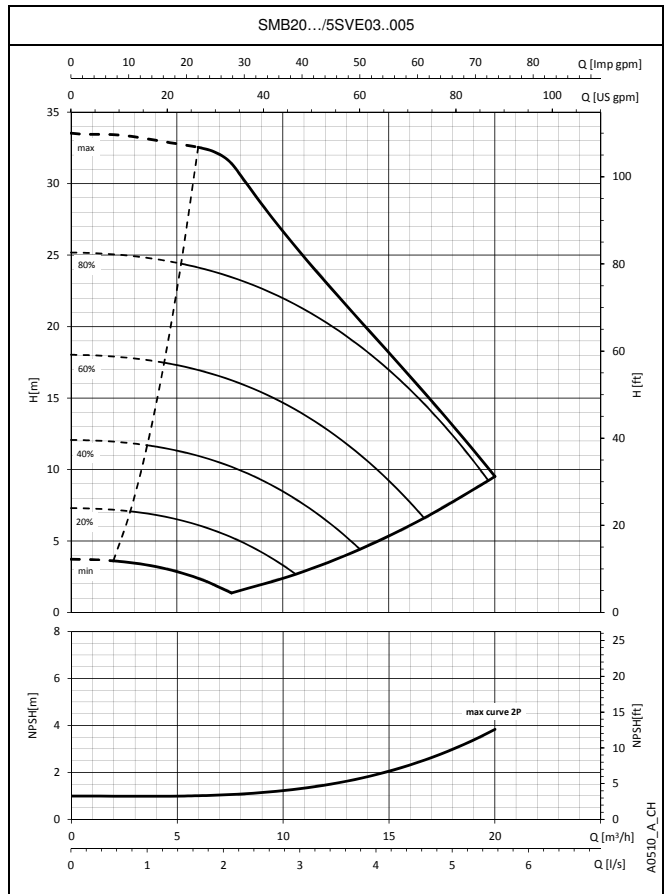
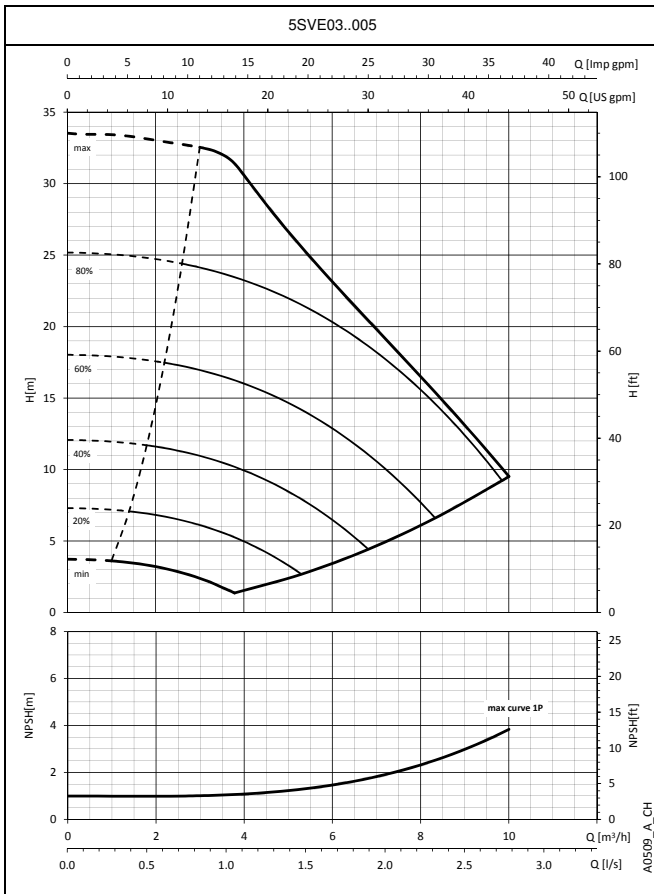

The performance curves do not take into account flow resistance in the valves and piping. The curves show the performance with one, two and three pumps running. These performances are valid for liquids with density  $\rho = 1 \text{ Kg/dm}^3$  and kinematic viscosity  $\nu = 1 \text{ mm}^2/\text{sec}$ . The declared NPSH values are laboratory values; for practical use we recommend increasing these values by 0,5 m.

## SMB.../SVE BOOSTER SETS SERIES OPERATING CHARACTERISTICS

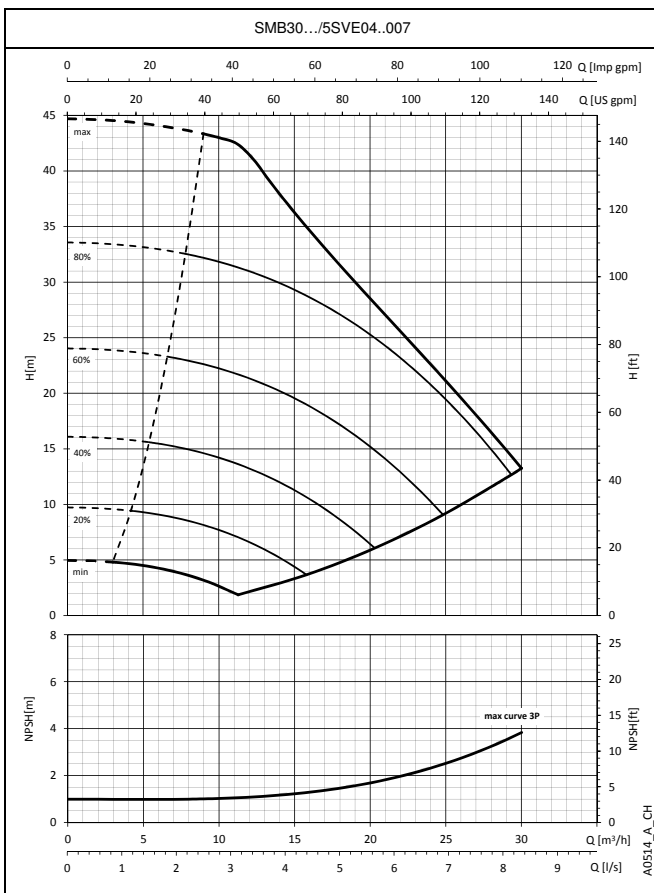
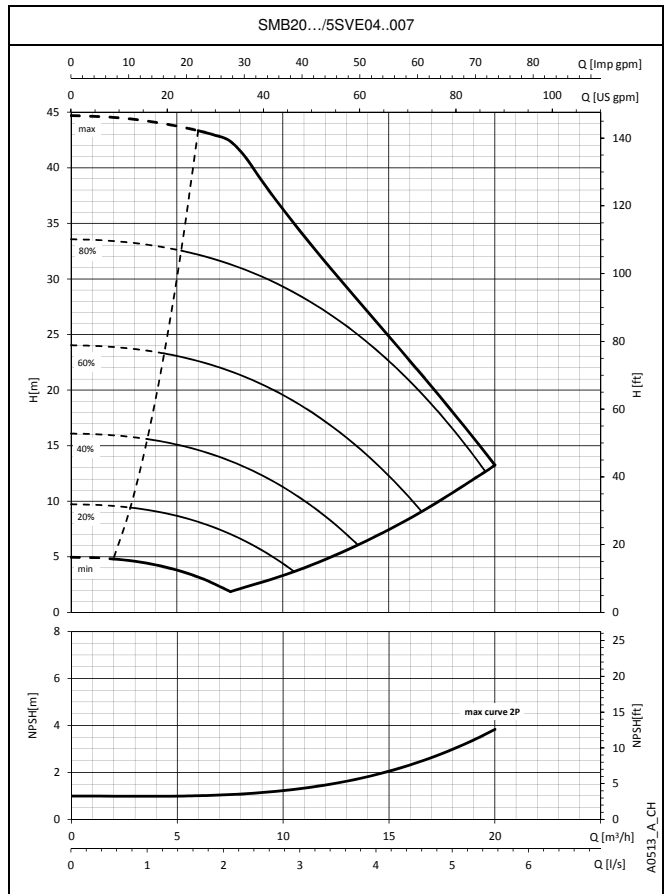
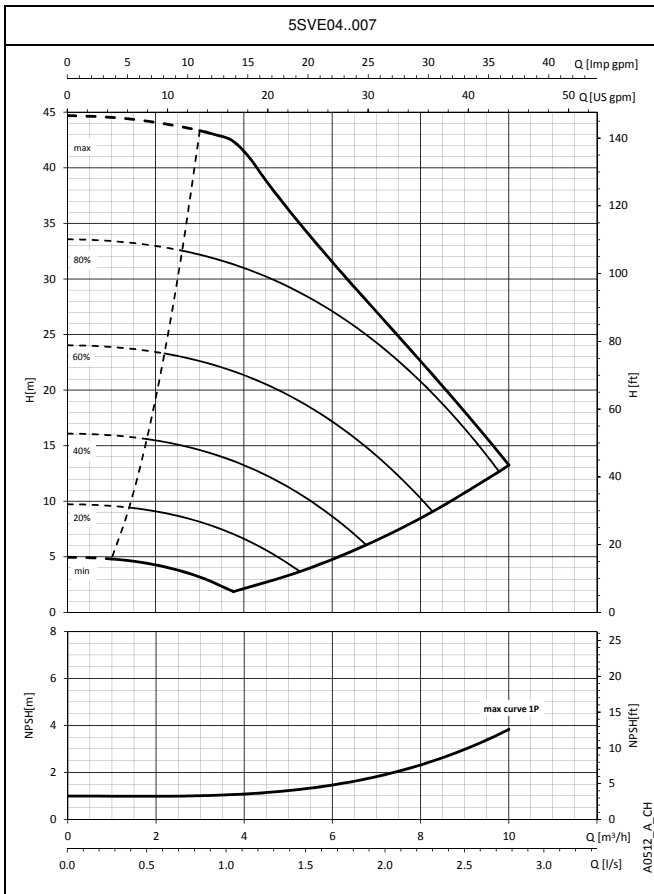

The performance curves do not take into account flow resistance in the valves and piping. The curves show the performance with one, two and three pumps running. These performances are valid for liquids with density  $\rho = 1 \text{ Kg/dm}^3$  and kinematic viscosity  $\nu = 1 \text{ mm}^2/\text{sec}$ . The declared NPSH values are laboratory values; for practical use we recommend increasing these values by 0,5 m.

## SMB.../SVE BOOSTER SETS SERIES OPERATING CHARACTERISTICS

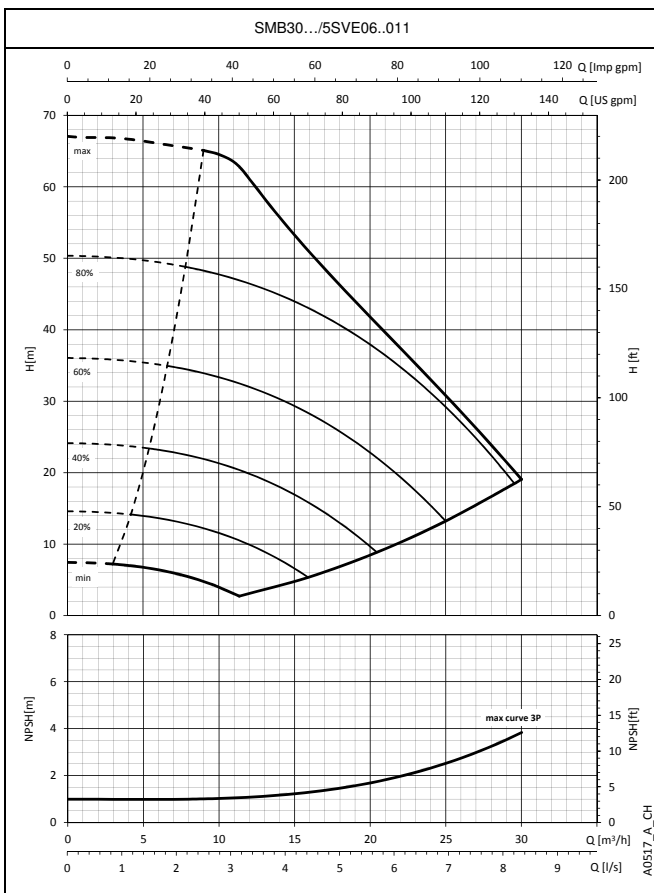
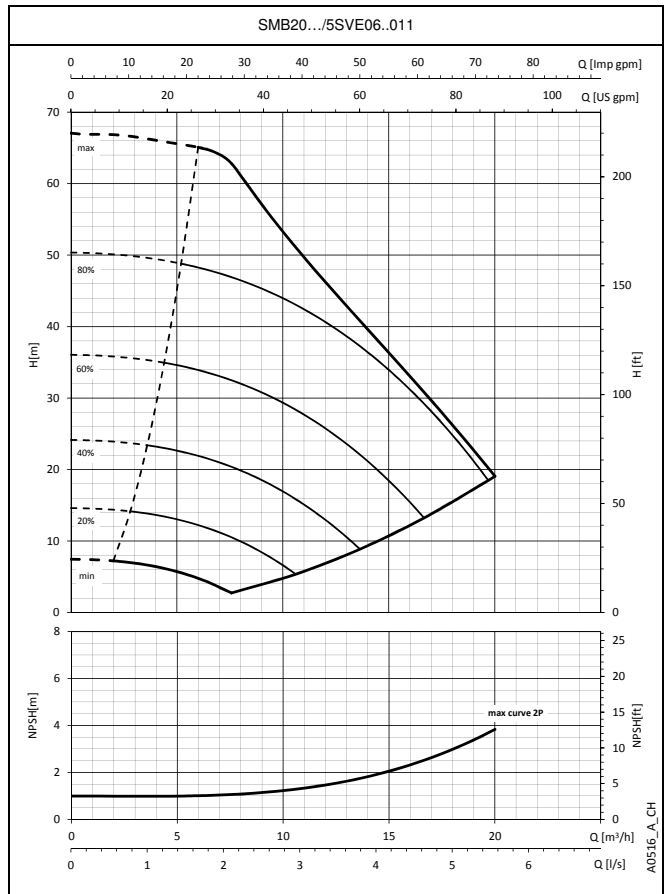
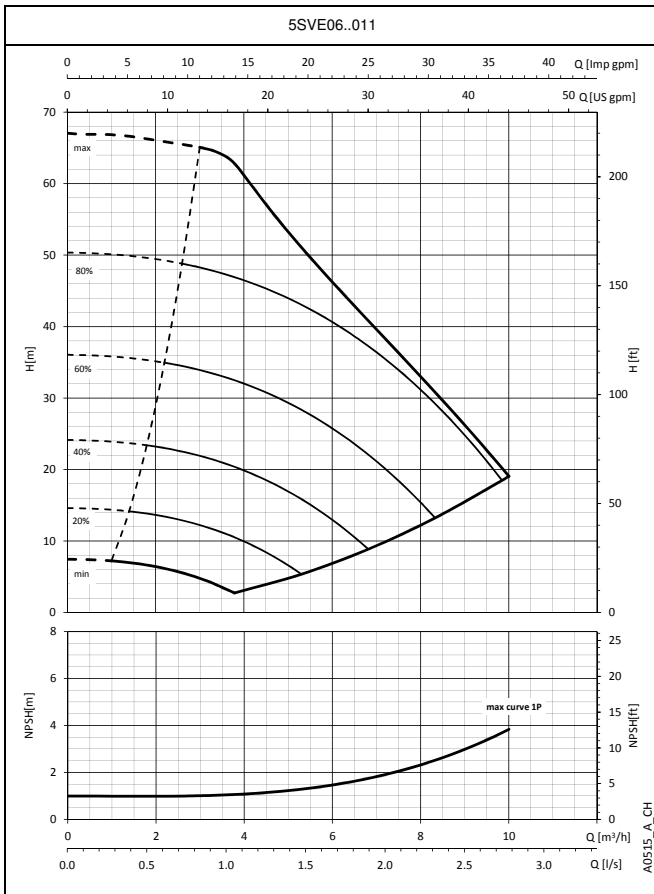

The performance curves do not take into account flow resistance in the valves and piping. The curves show the performance with one, two and three pumps running. These performances are valid for liquids with density  $\rho = 1 \text{ Kg/dm}^3$  and kinematic viscosity  $\nu = 1 \text{ mm}^2/\text{sec}$ . The declared NPSH values are laboratory values; for practical use we recommend increasing these values by 0,5 m.

## SMB.../SVE BOOSTER SETS SERIES OPERATING CHARACTERISTICS

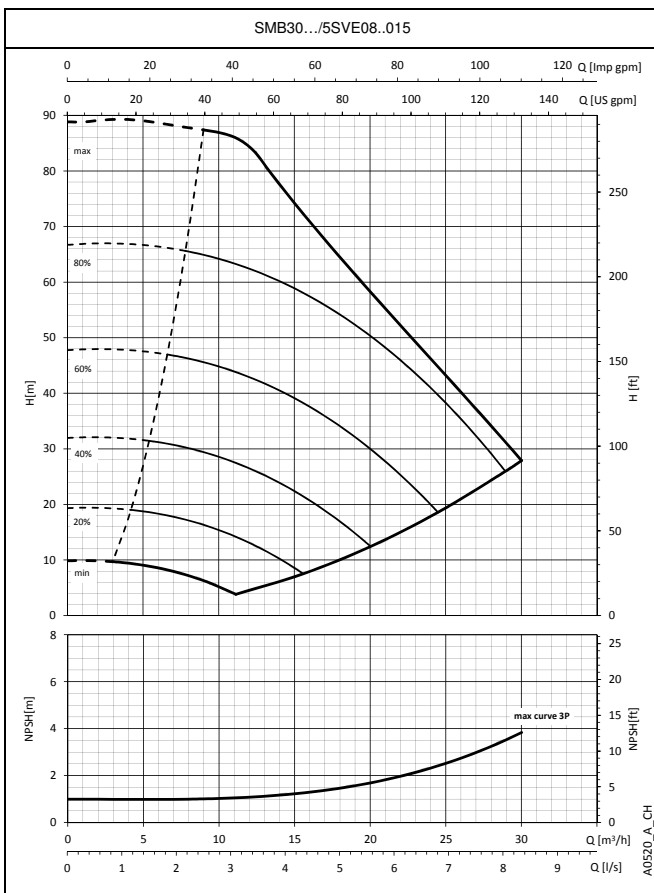
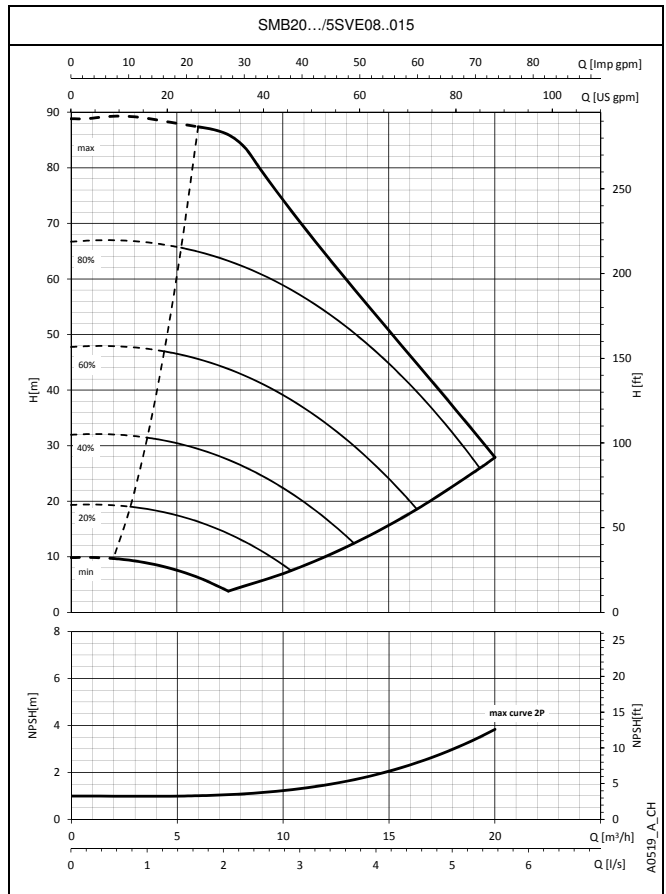
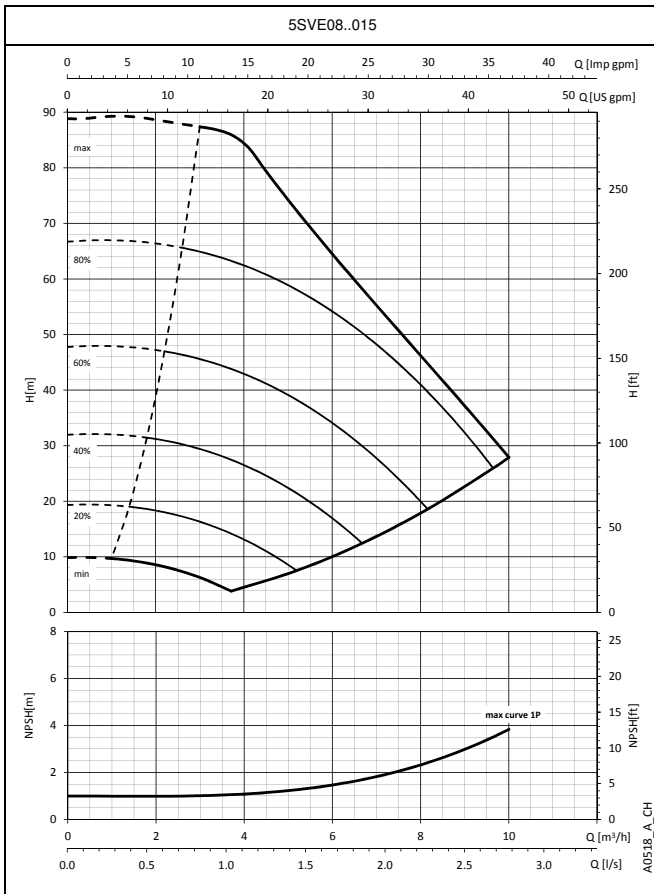

The performance curves do not take into account flow resistance in the valves and piping. The curves show the performance with one, two and three pumps running. These performances are valid for liquids with density  $\rho = 1 \text{ Kg/dm}^3$  and kinematic viscosity  $\nu = 1 \text{ mm}^2/\text{sec}$ . The declared NPSH values are laboratory values; for practical use we recommend increasing these values by 0,5 m.

## SMB.../SVE BOOSTER SETS SERIES OPERATING CHARACTERISTICS

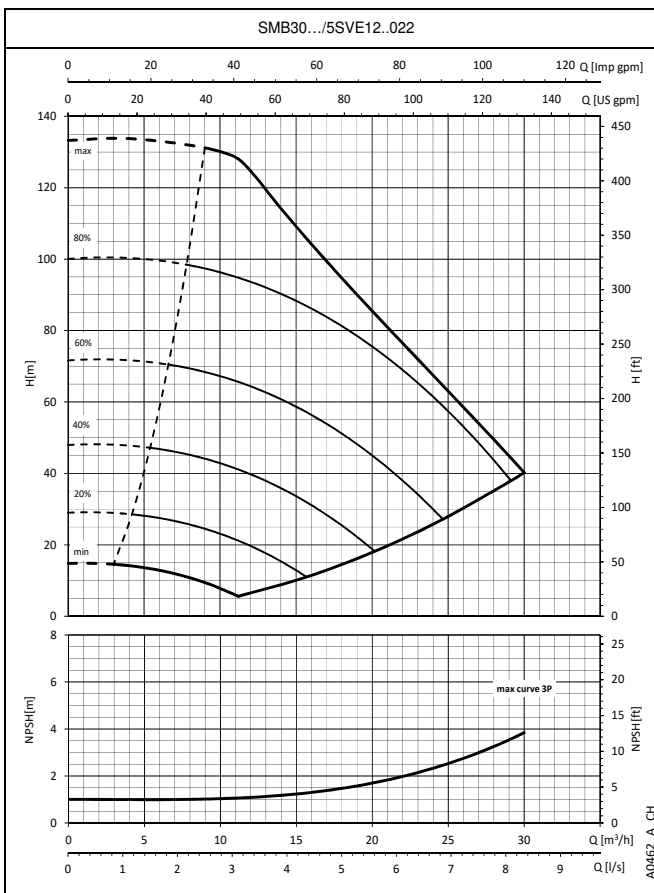
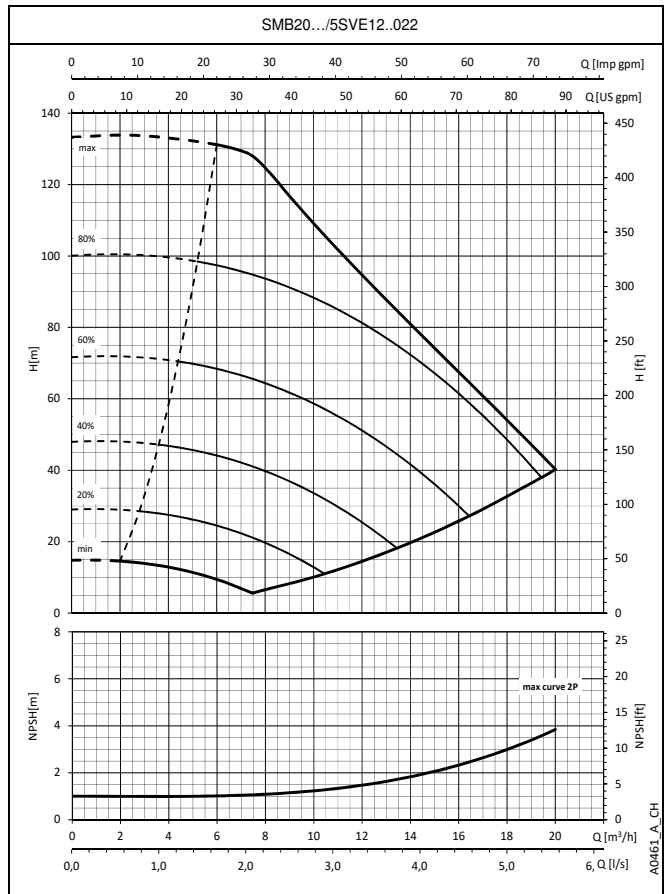
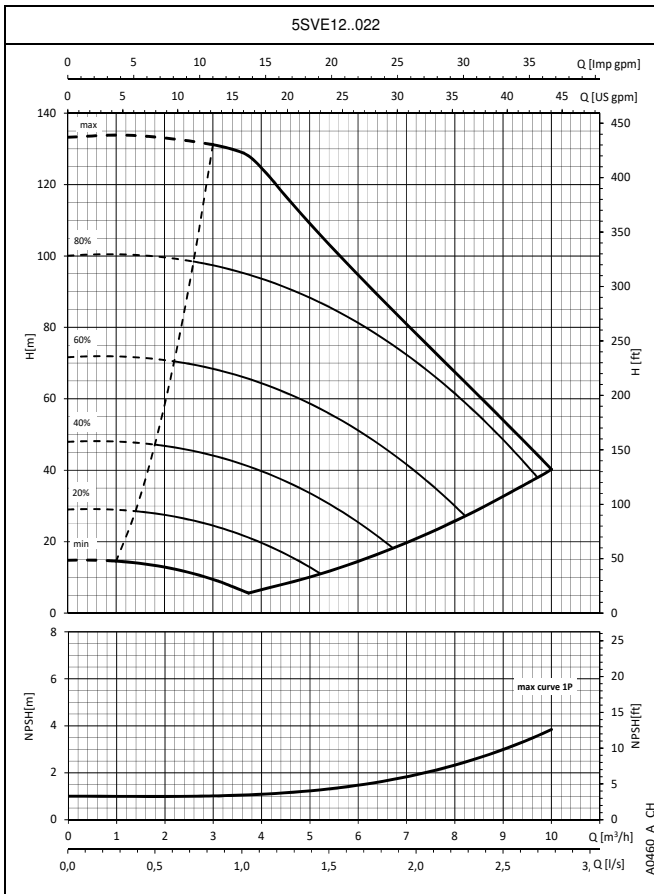

The performance curves do not take into account flow resistance in the valves and piping. The curves show the performance with one, two and three pumps running. These performances are valid for liquids with density  $\rho = 1 \text{ Kg/dm}^3$  and kinematic viscosity  $\nu = 1 \text{ mm}^2/\text{sec}$ . The declared NPSH values are laboratory values; for practical use we recommend increasing these values by 0,5 m.

## SMB.../SVE BOOSTER SETS SERIES OPERATING CHARACTERISTICS

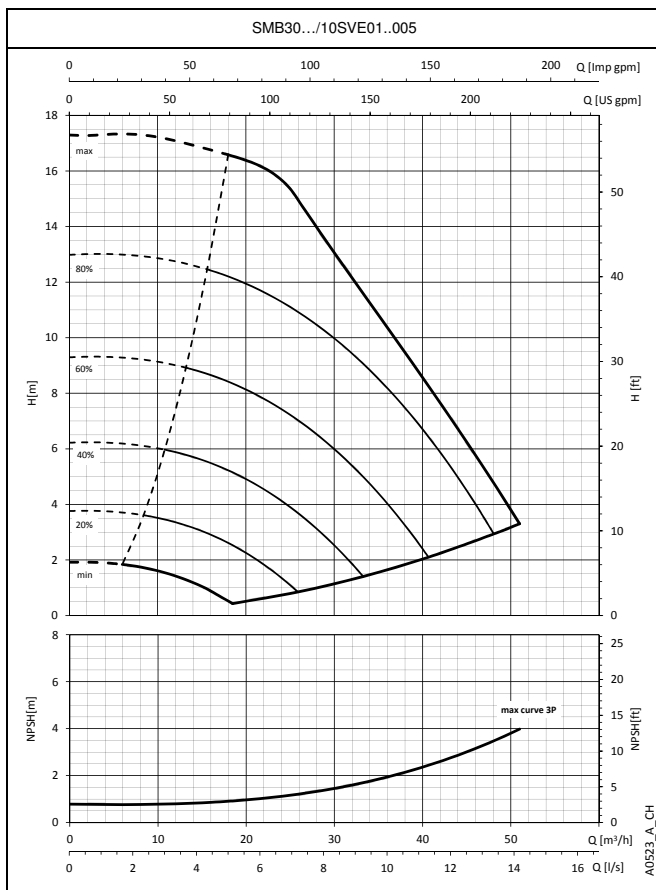
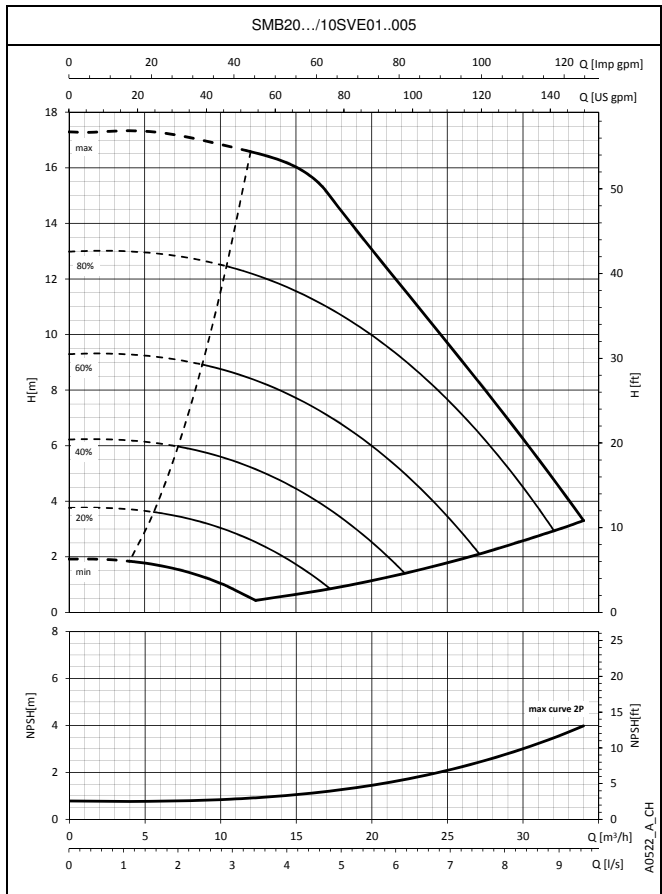
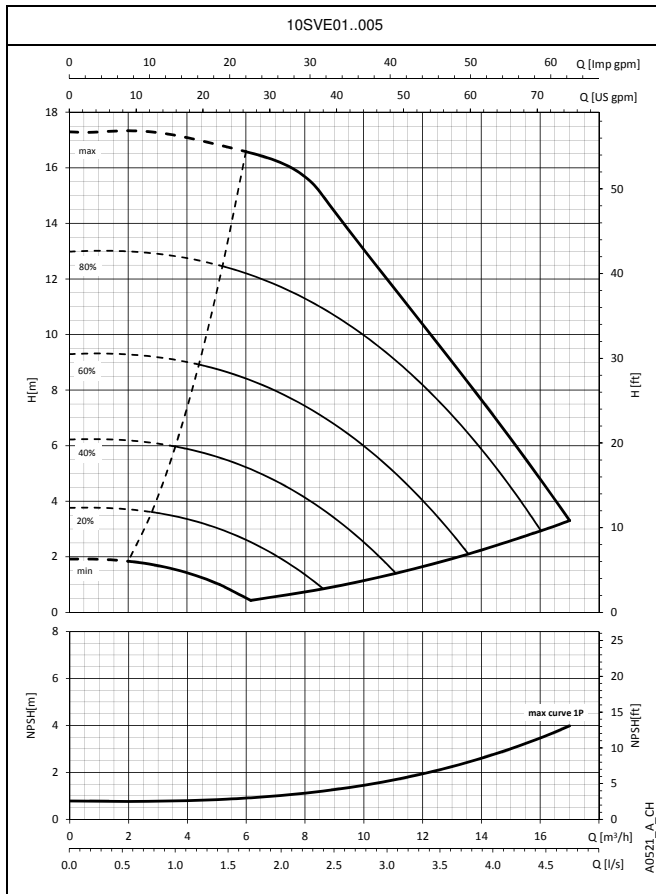

The performance curves do not take into account flow resistance in the valves and piping. The curves show the performance with one, two and three pumps running. These performances are valid for liquids with density  $\rho = 1 \text{ Kg/dm}^3$  and kinematic viscosity  $\nu = 1 \text{ mm}^2/\text{sec}$ . The declared NPSH values are laboratory values; for practical use we recommend increasing these values by 0,5 m.

## SMB.../SVE BOOSTER SETS SERIES OPERATING CHARACTERISTICS

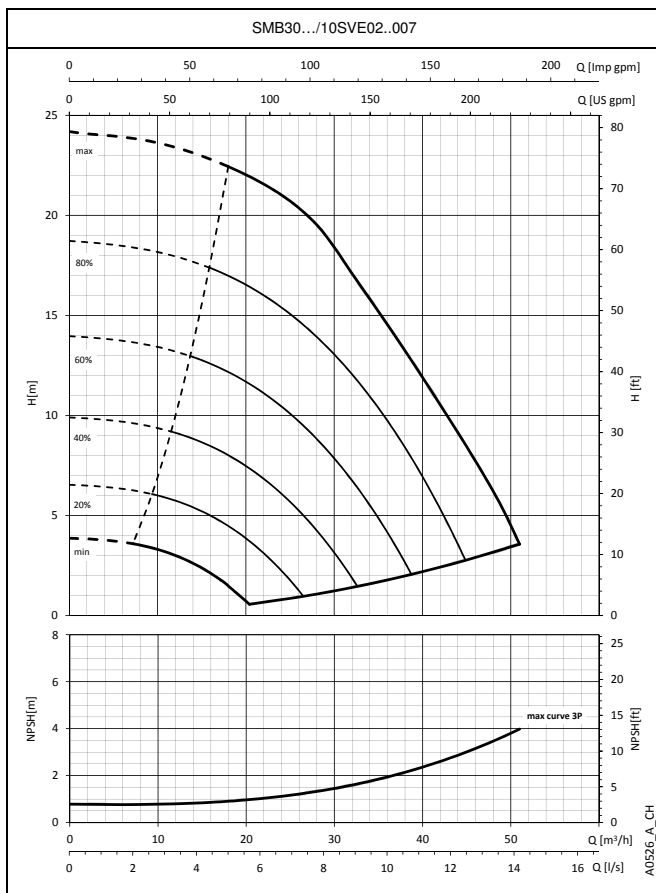
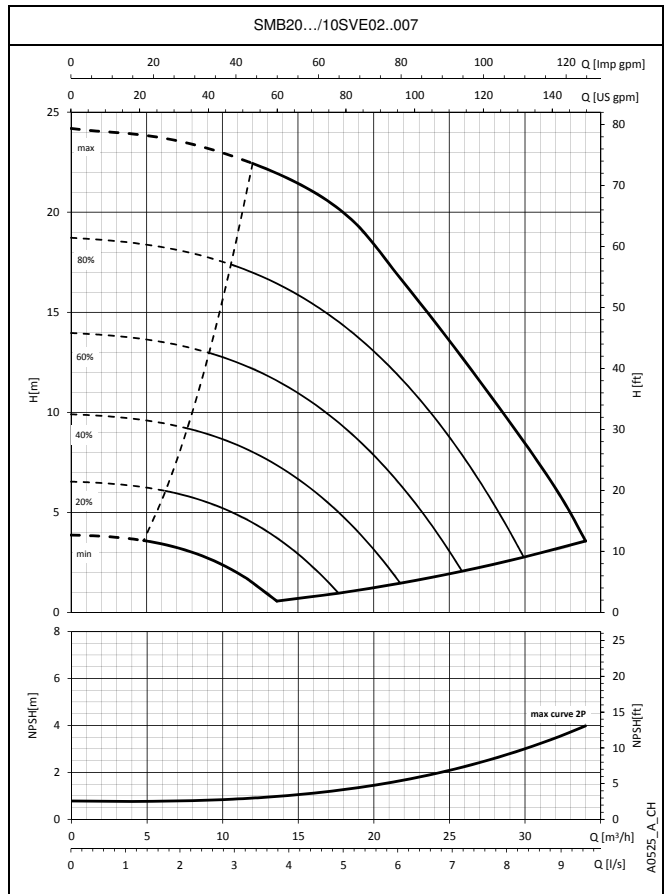
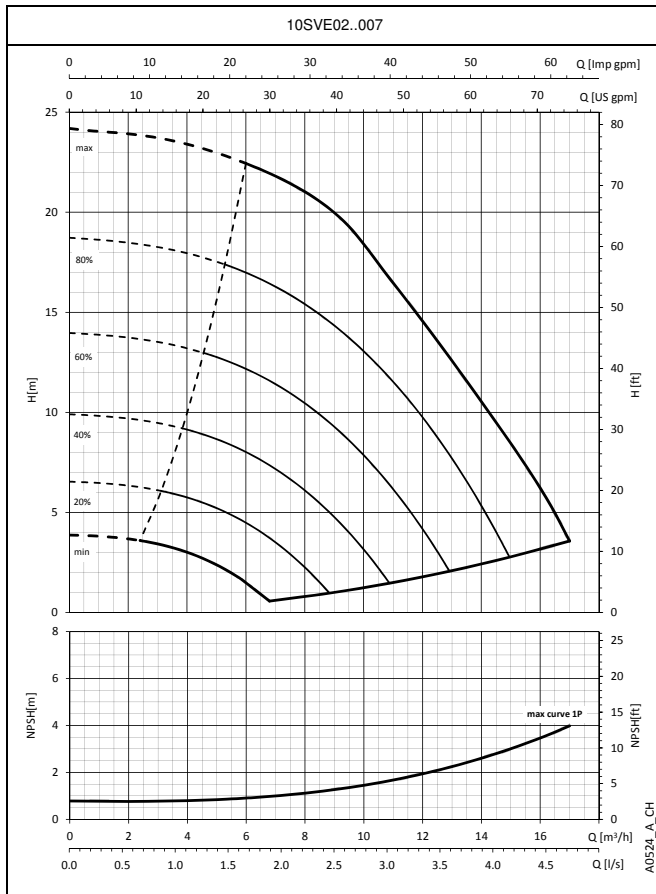

The performance curves do not take into account flow resistance in the valves and piping. The curves show the performance with one, two and three pumps running. These performances are valid for liquids with density  $\rho = 1 \text{ Kg/dm}^3$  and kinematic viscosity  $\nu = 1 \text{ mm}^2/\text{sec}$ . The declared NPSH values are laboratory values; for practical use we recommend increasing these values by 0,5 m.

**SMB.../SVE BOOSTER SETS SERIES  
OPERATING CHARACTERISTICS**

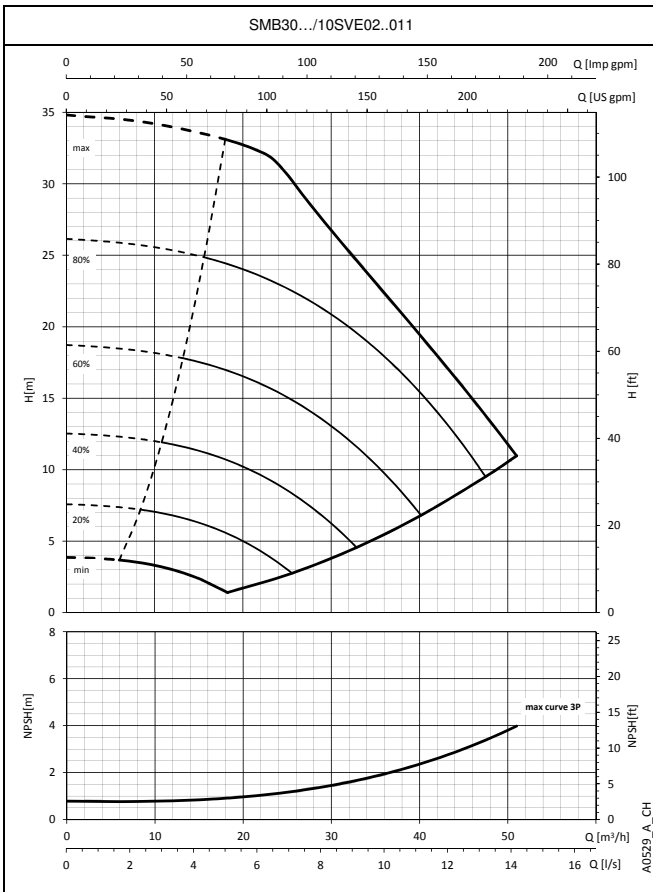
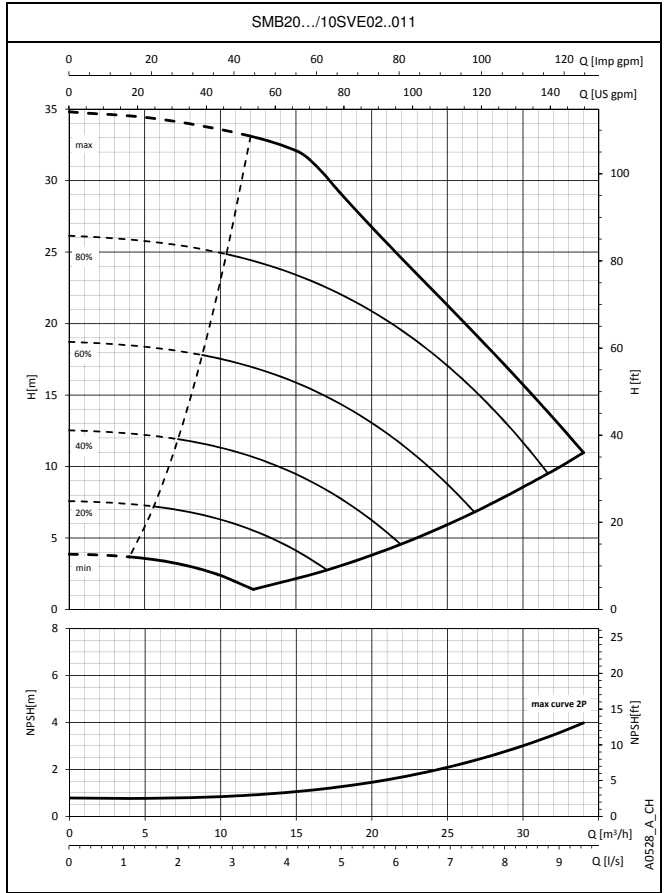
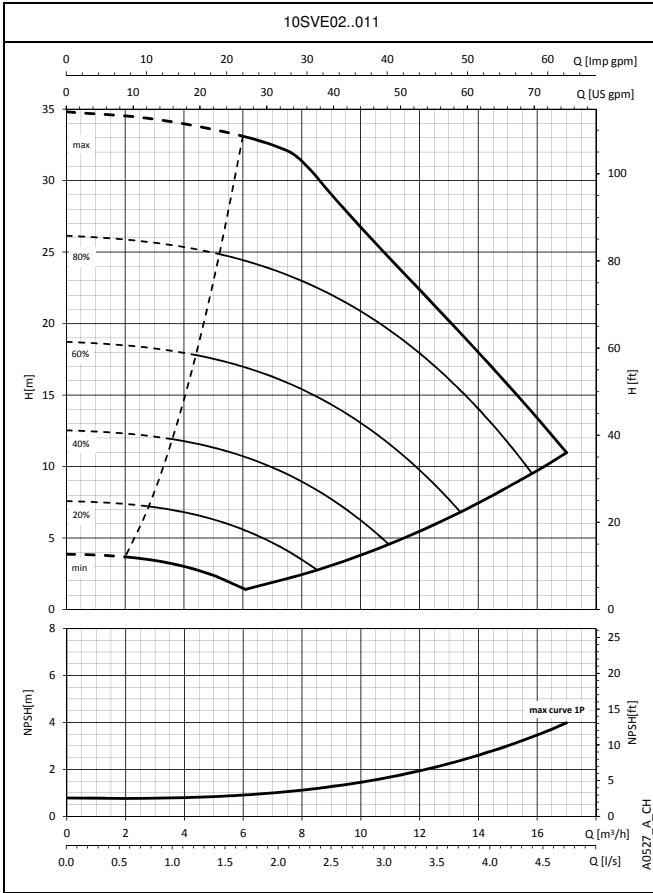

The performance curves do not take into account flow resistance in the valves and piping. The curves show the performance with one, two and three pumps running. These performances are valid for liquids with density  $\rho = 1 \text{ Kg/dm}^3$  and kinematic viscosity  $\nu = 1 \text{ mm}^2/\text{sec}$ . The declared NPSH values are laboratory values; for practical use we recommend increasing these values by 0,5 m.

## SMB.../SVE BOOSTER SETS SERIES OPERATING CHARACTERISTICS

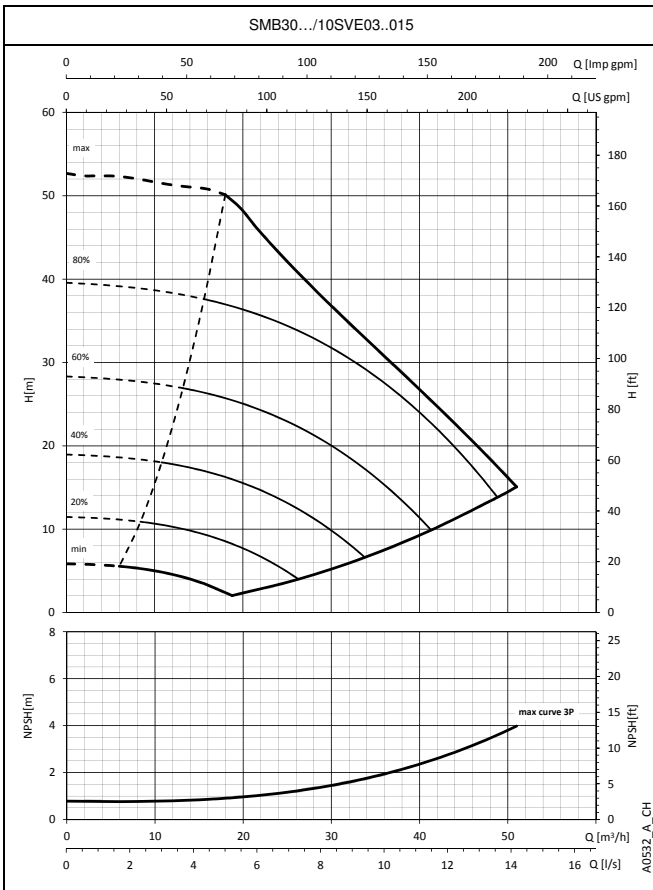
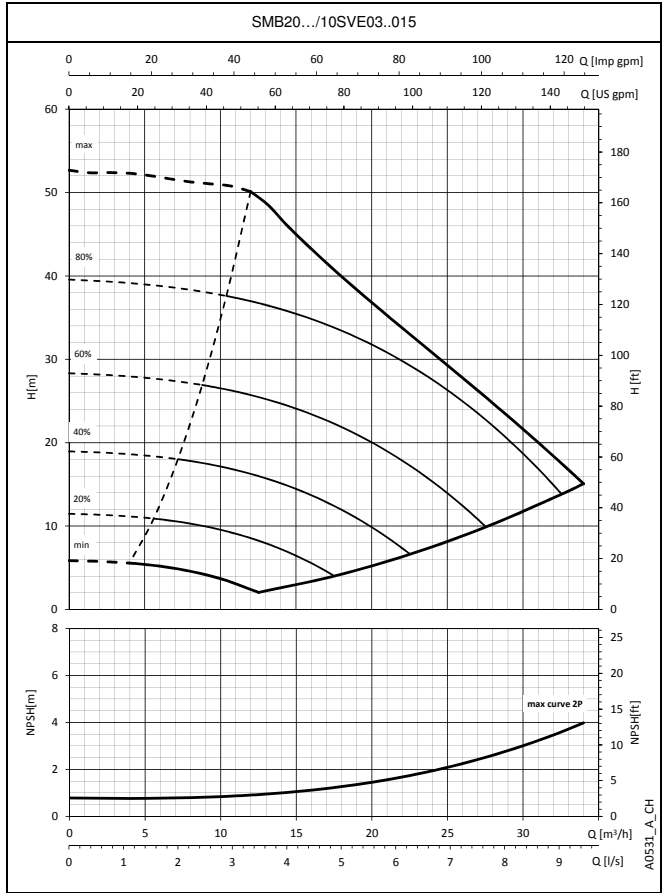
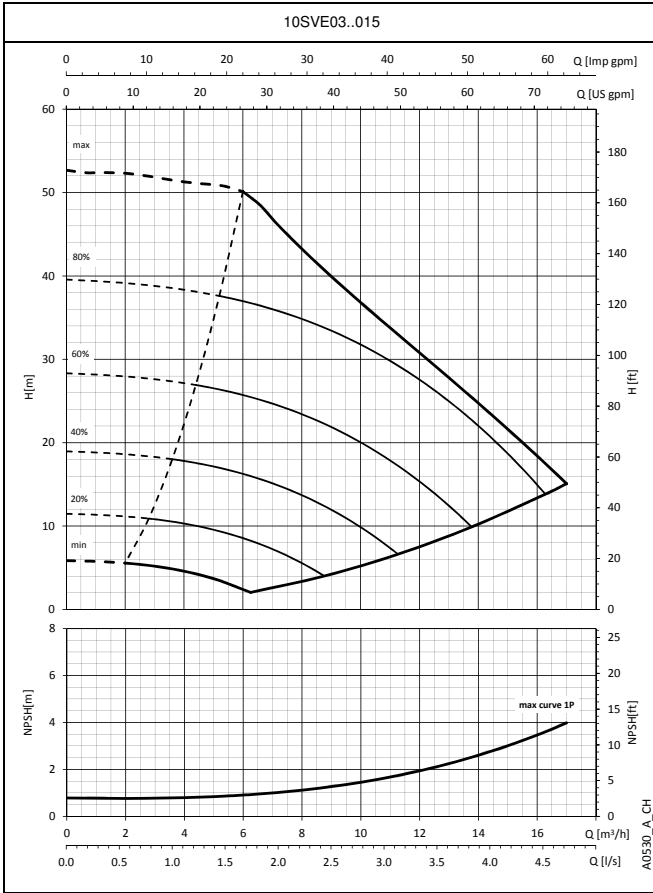

The performance curves do not take into account flow resistance in the valves and piping. The curves show the performance with one, two and three pumps running. These performances are valid for liquids with density  $\rho = 1 \text{ Kg/dm}^3$  and kinematic viscosity  $\nu = 1 \text{ mm}^2/\text{sec}$ . The declared NPSH values are laboratory values; for practical use we recommend increasing these values by 0,5 m.

**SMB.../SVE BOOSTER SETS SERIES  
OPERATING CHARACTERISTICS**

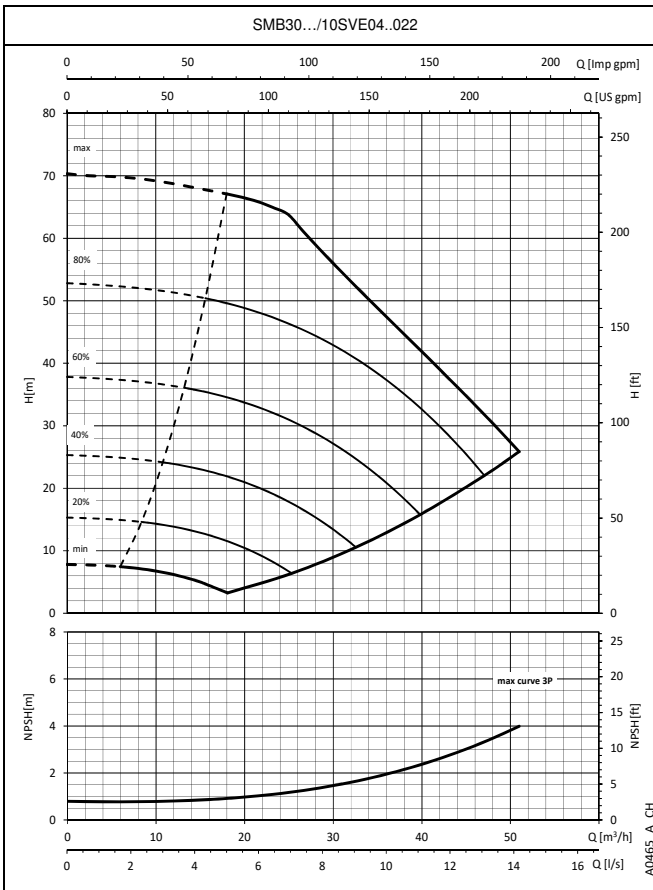
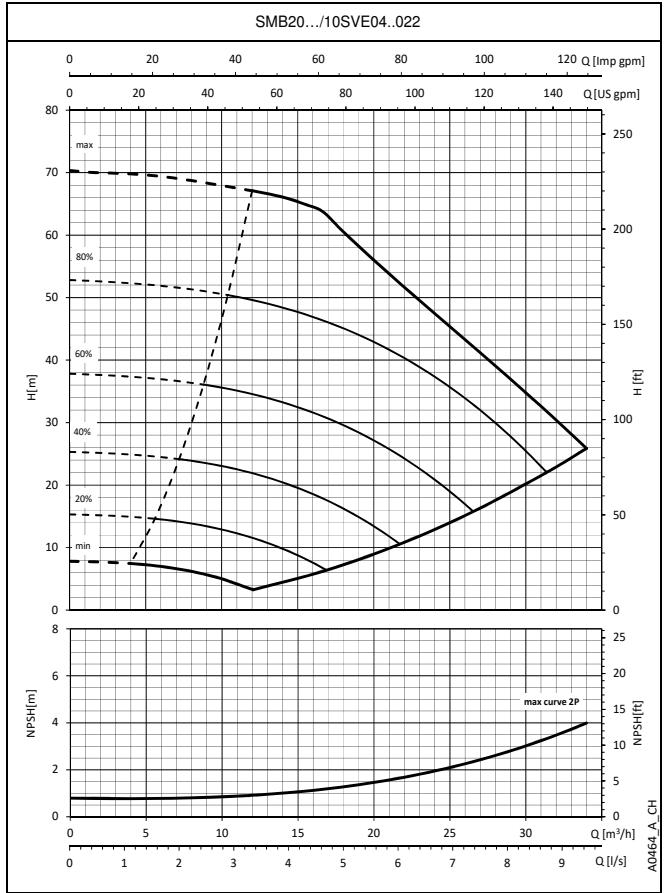
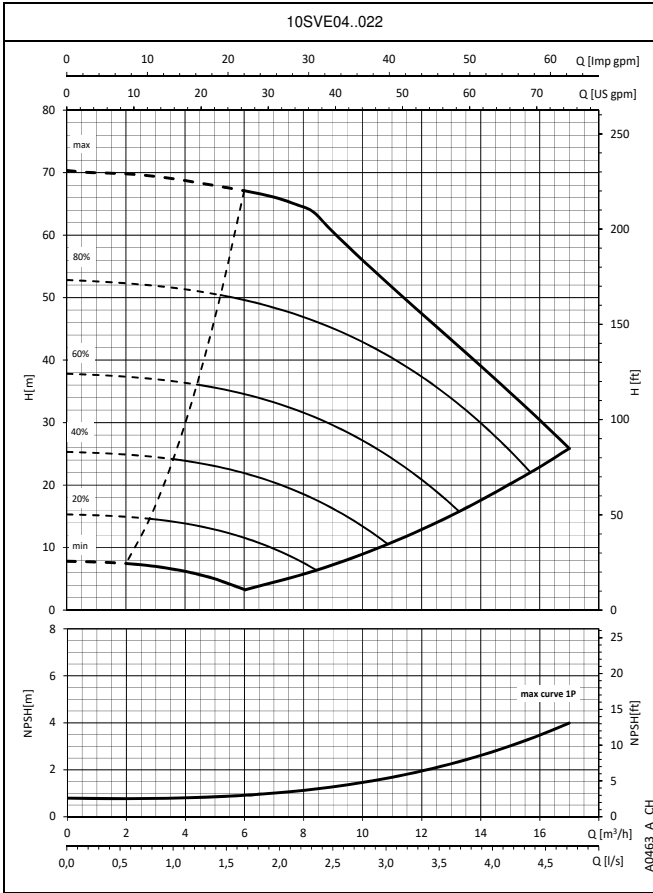

The performance curves do not take into account flow resistance in the valves and piping. The curves show the performance with one, two and three pumps running. These performances are valid for liquids with density  $\rho = 1 \text{ Kg/dm}^3$  and kinematic viscosity  $\nu = 1 \text{ mm}^2/\text{sec}$ . The declared NPSH values are laboratory values; for practical use we recommend increasing these values by 0,5 m.

## SMB.../SVE BOOSTER SETS SERIES OPERATING CHARACTERISTICS

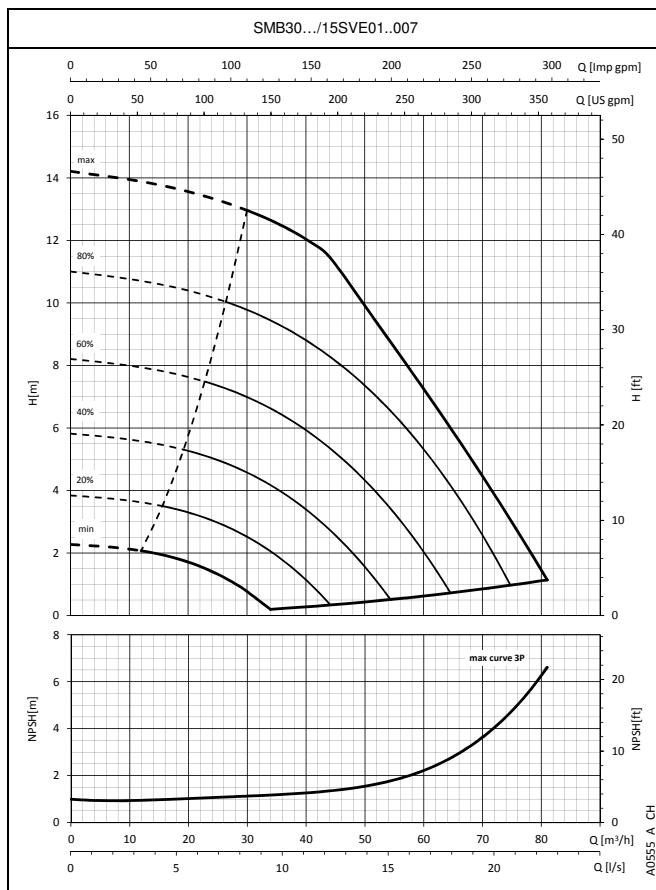
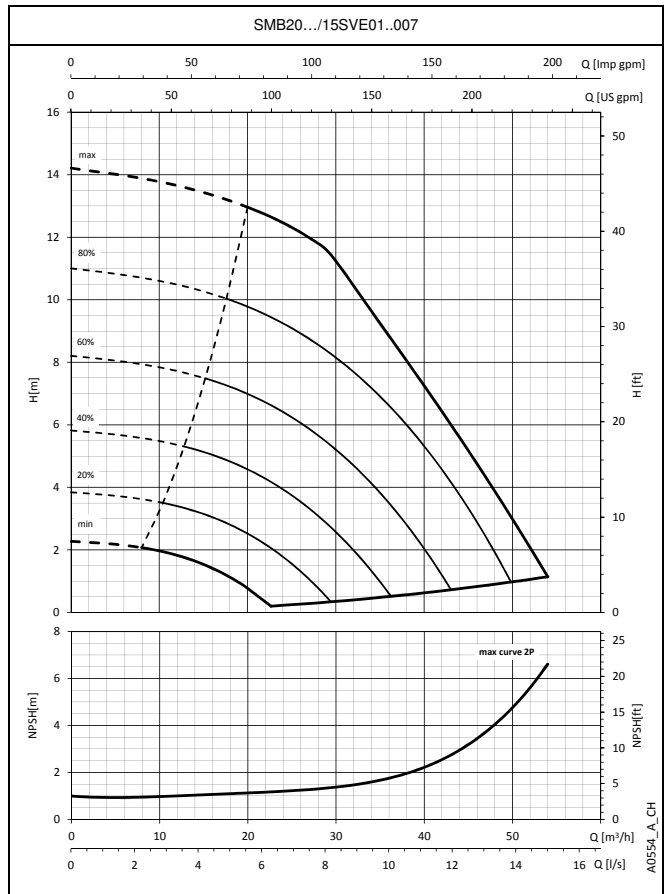
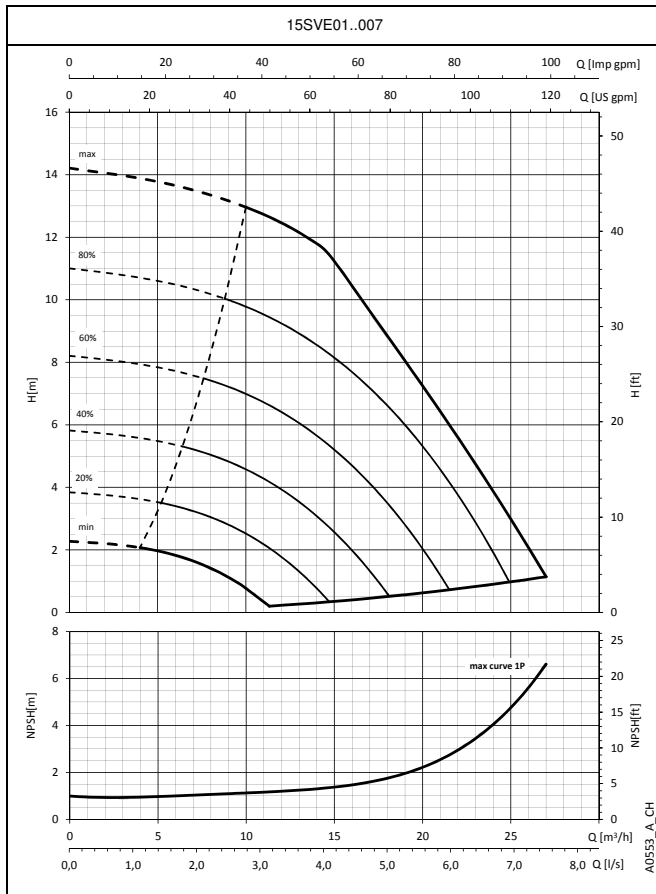

The performance curves do not take into account flow resistance in the valves and piping. The curves show the performance with one, two and three pumps running. These performances are valid for liquids with density  $\rho = 1 \text{ Kg/dm}^3$  and kinematic viscosity  $\nu = 1 \text{ mm}^2/\text{sec}$ . The declared NPSH values are laboratory values; for practical use we recommend increasing these values by 0,5 m.

### SMB.../SVE BOOSTER SETS SERIES OPERATING CHARACTERISTICS

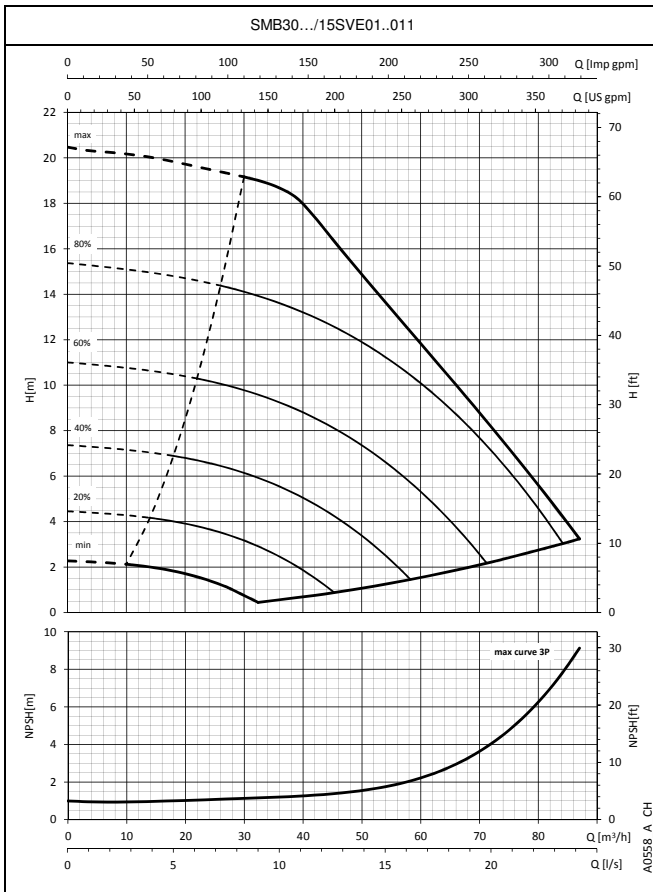
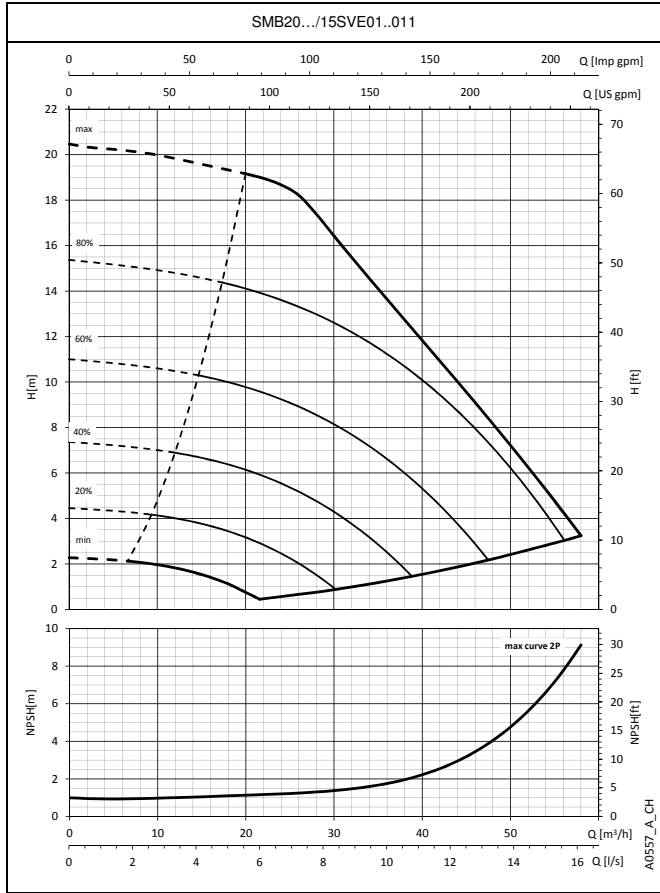
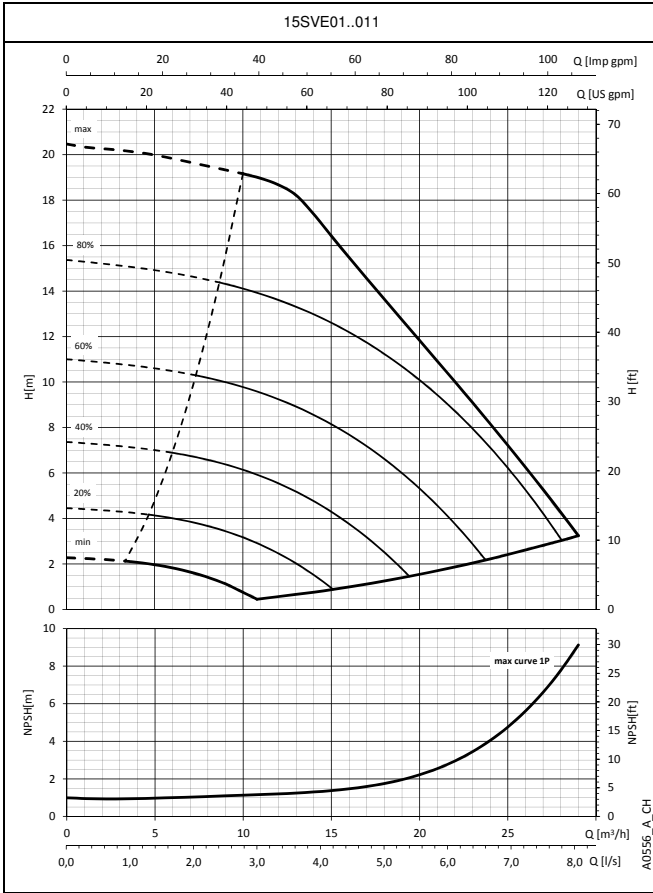

The performance curves do not take into account flow resistance in the valves and piping. The curves show the performance with one, two and three pumps running. These performances are valid for liquids with density  $\rho = 1 \text{ Kg/dm}^3$  and kinematic viscosity  $\nu = 1 \text{ mm}^2/\text{sec}$ . The declared NPSH values are laboratory values; for practical use we recommend increasing these values by 0,5 m.

**SMB.../SVE BOOSTER SETS SERIES  
OPERATING CHARACTERISTICS**

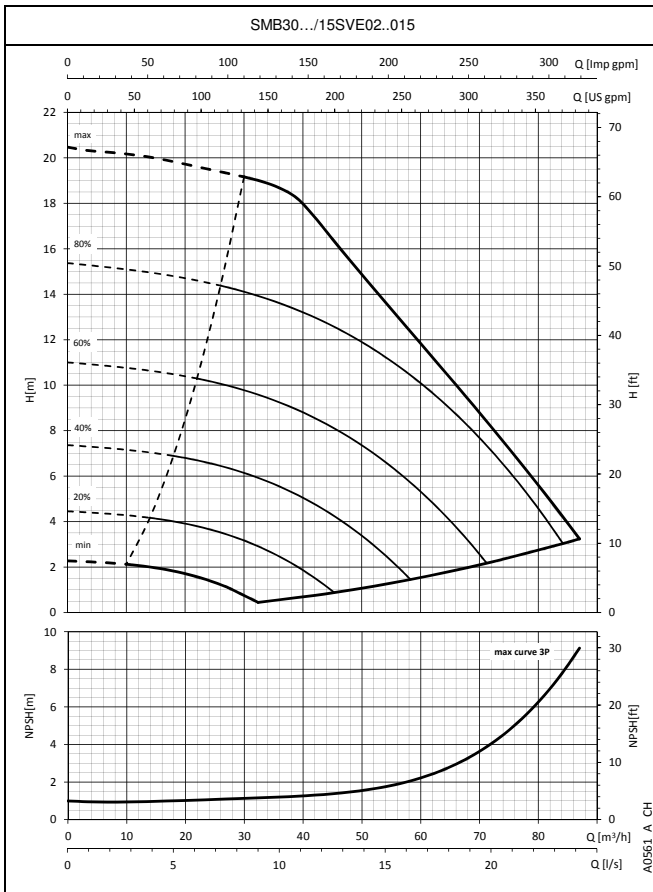
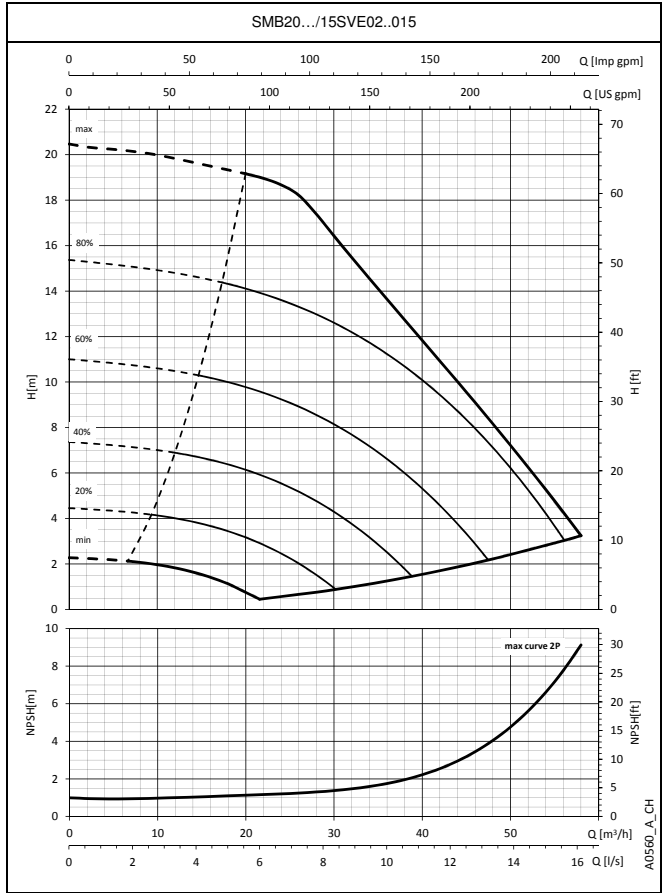
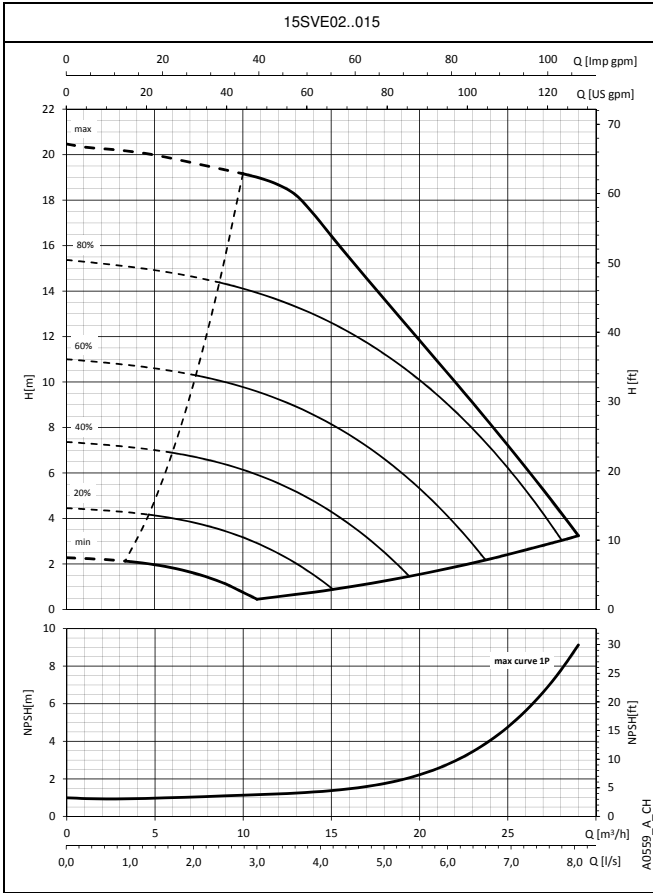

The performance curves do not take into account flow resistance in the valves and piping. The curves show the performance with one, two and three pumps running.  
These performances are valid for liquids with density  $\rho = 1 \text{ Kg/dm}^3$  and kinematic viscosity  $\nu = 1 \text{ mm}^2/\text{sec}$ .  
The declared NPSH values are laboratory values; for practical use we recommend increasing these values by 0,5 m.

## SMB.../SVE BOOSTER SETS SERIES OPERATING CHARACTERISTICS

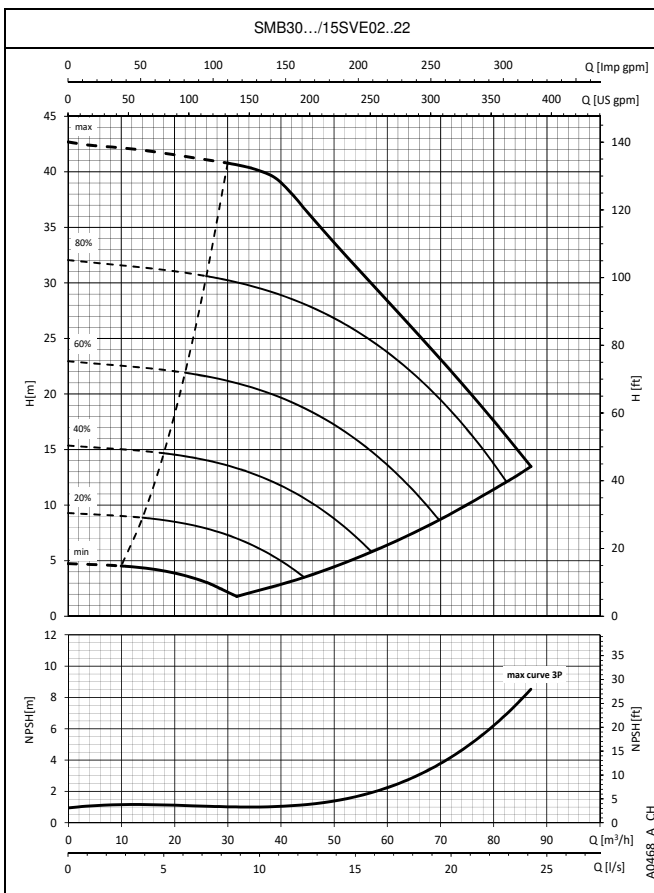
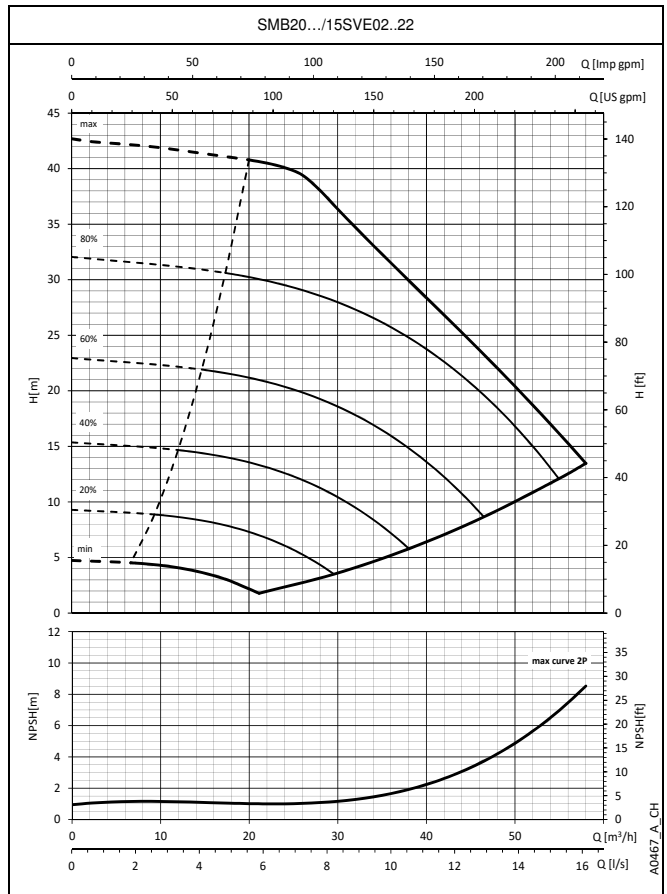
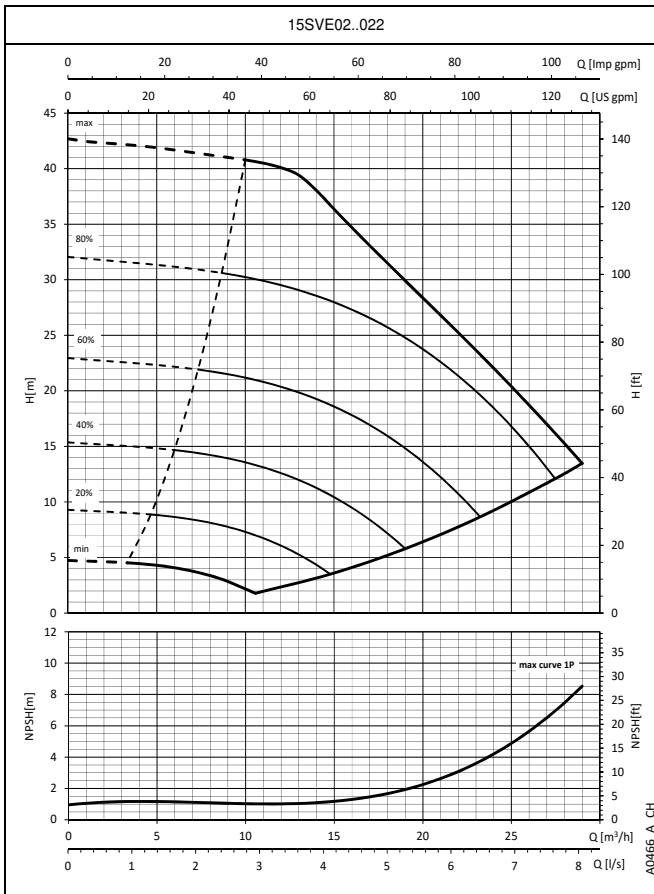

The performance curves do not take into account flow resistance in the valves and piping. The curves show the performance with one, two and three pumps running. These performances are valid for liquids with density  $\rho = 1 \text{ Kg/dm}^3$  and kinematic viscosity  $\nu = 1 \text{ mm}^2/\text{sec}$ . The declared NPSH values are laboratory values; for practical use we recommend increasing these values by 0,5 m.

## SMB.../SVE BOOSTER SETS SERIES OPERATING CHARACTERISTICS

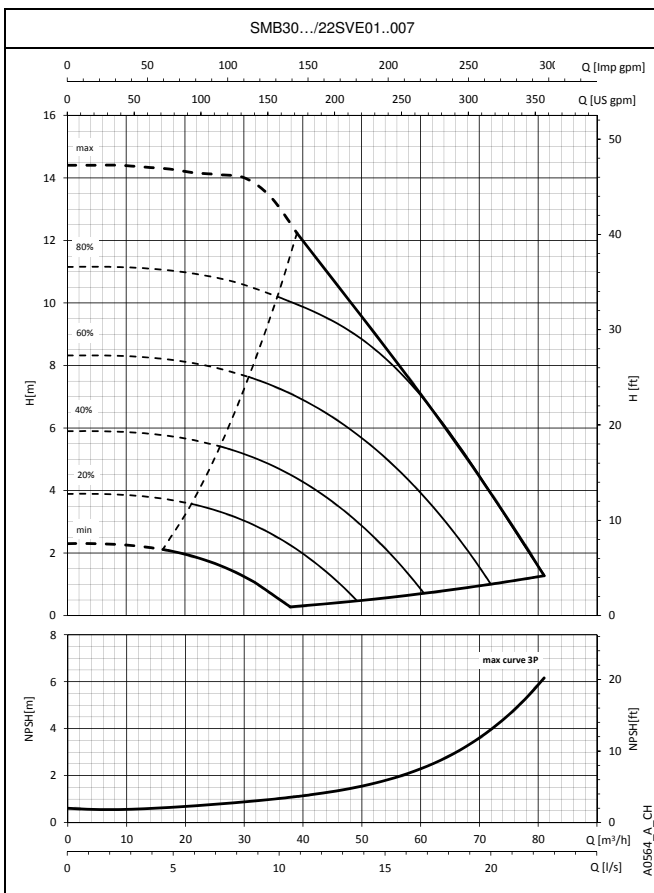
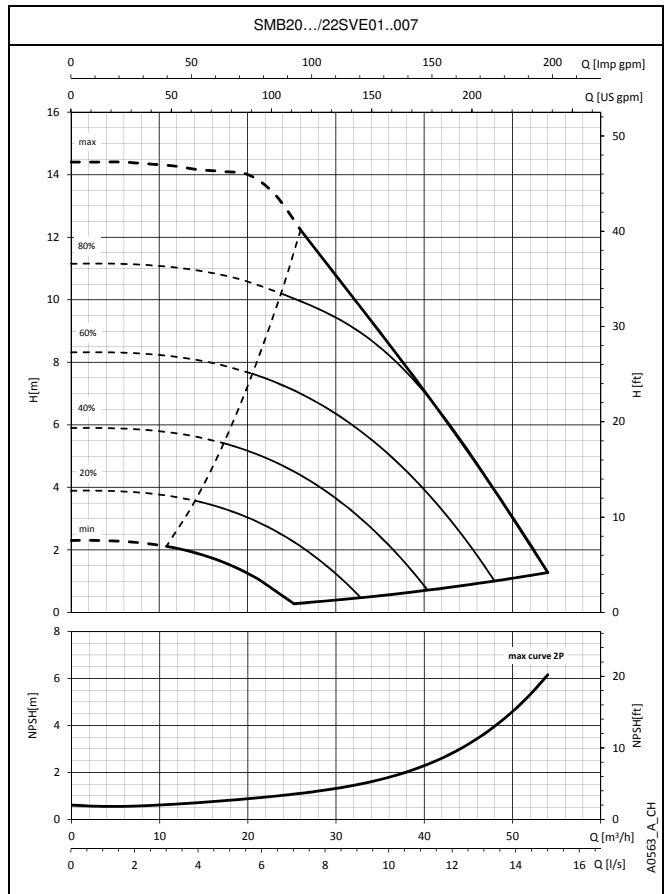
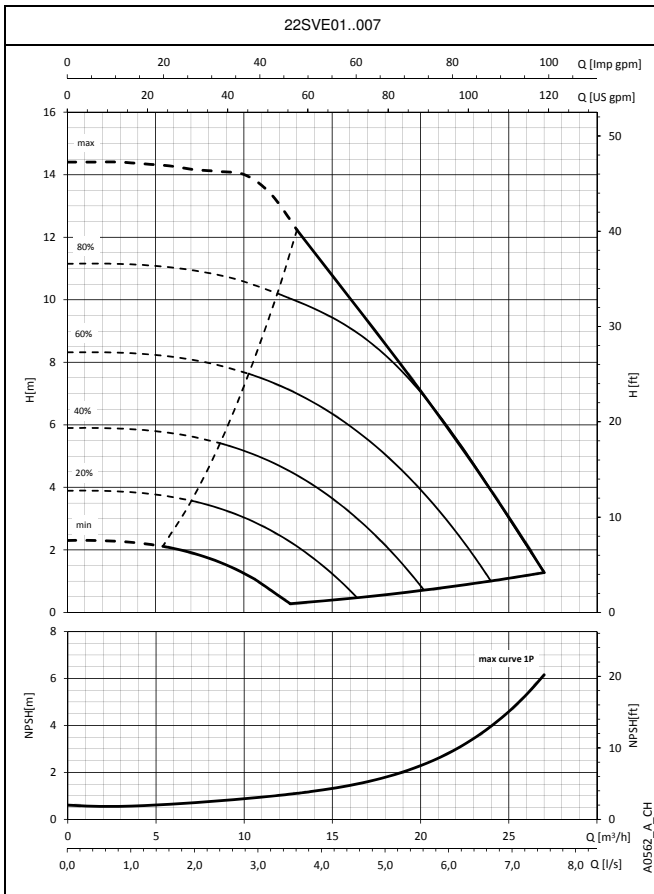

The performance curves do not take into account flow resistance in the valves and piping. The curves show the performance with one, two and three pumps running. These performances are valid for liquids with density  $\rho = 1 \text{ Kg/dm}^3$  and kinematic viscosity  $\nu = 1 \text{ mm}^2/\text{sec}$ . The declared NPSH values are laboratory values; for practical use we recommend increasing these values by 0,5 m.

## SMB.../SVE BOOSTER SETS SERIES OPERATING CHARACTERISTICS

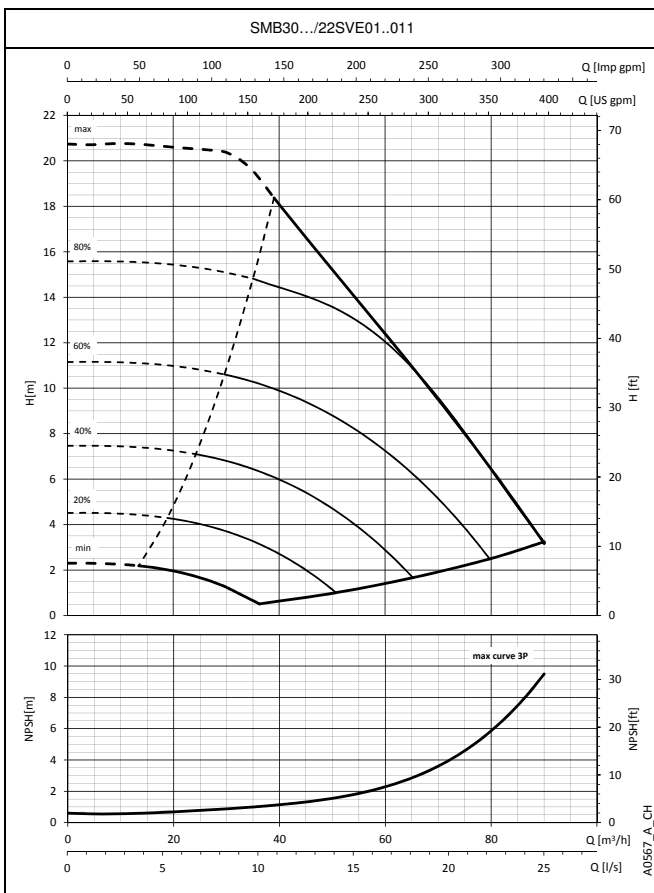
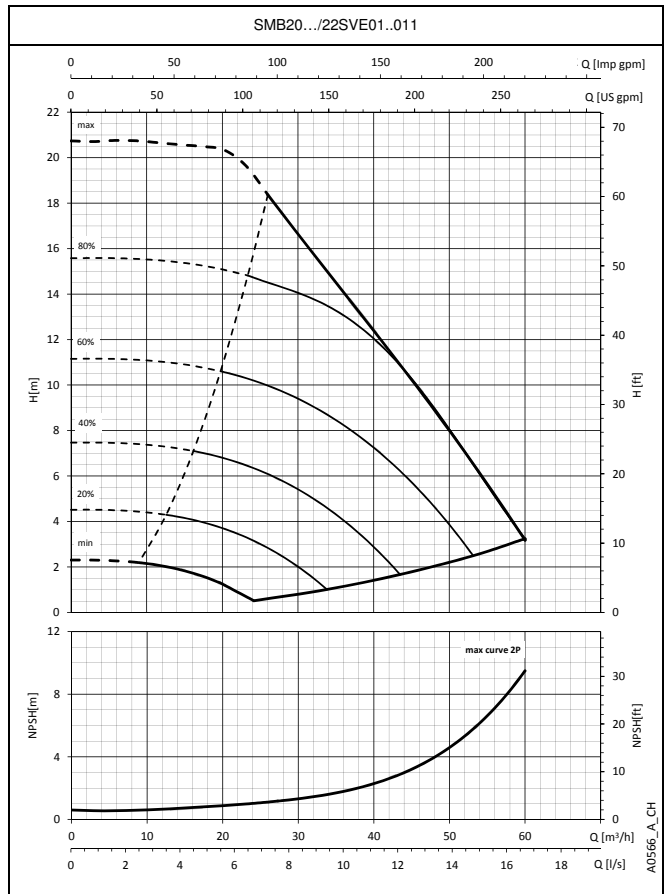
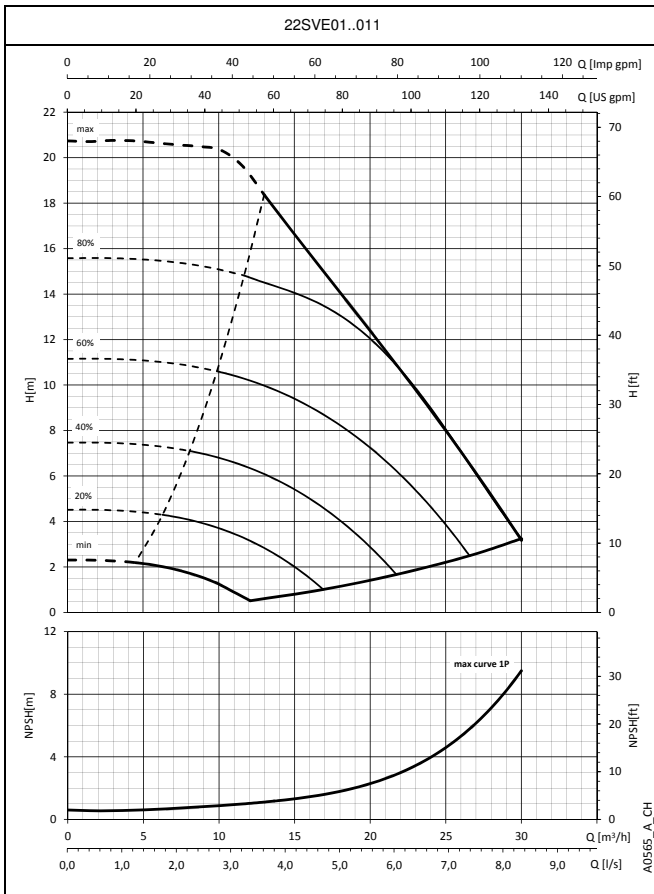

The performance curves do not take into account flow resistance in the valves and piping. The curves show the performance with one, two and three pumps running. These performances are valid for liquids with density  $\rho = 1 \text{ Kg/dm}^3$  and kinematic viscosity  $\nu = 1 \text{ mm}^2/\text{sec}$ . The declared NPSH values are laboratory values; for practical use we recommend increasing these values by 0,5 m.

## SMB.../SVE BOOSTER SETS SERIES OPERATING CHARACTERISTICS

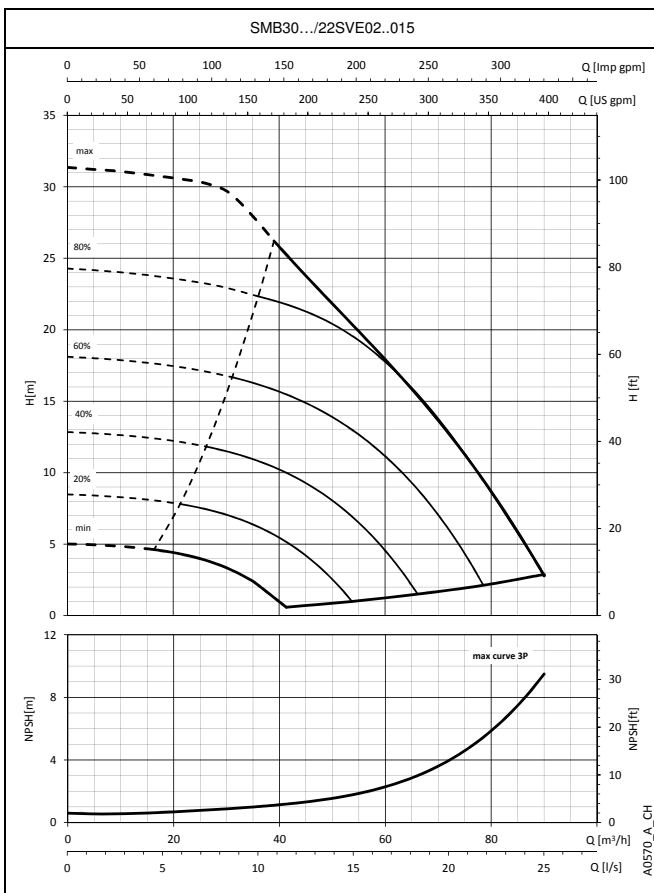
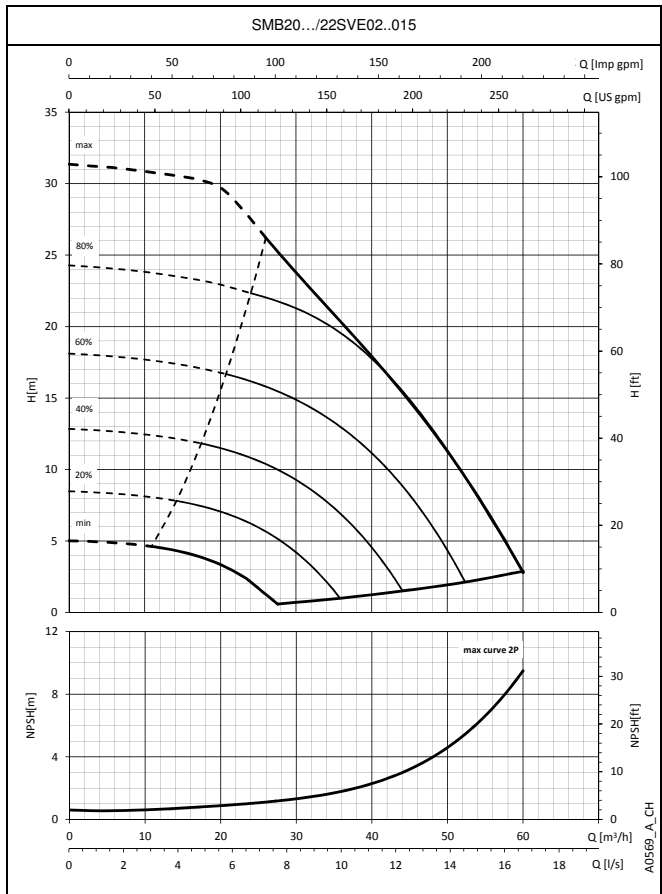
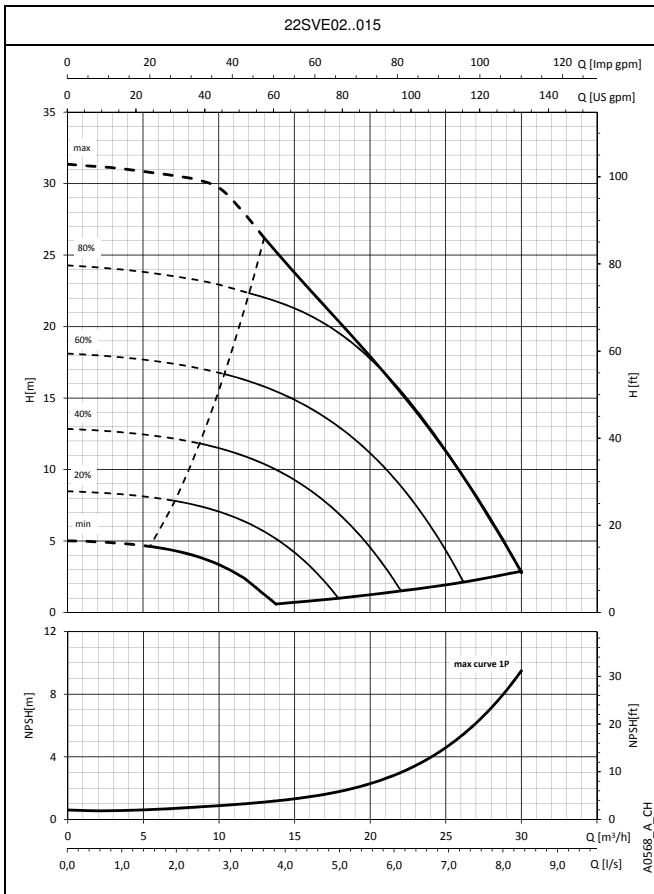

The performance curves do not take into account flow resistance in the valves and piping. The curves show the performance with one, two and three pumps running. These performances are valid for liquids with density  $\rho = 1 \text{ Kg/dm}^3$  and kinematic viscosity  $\nu = 1 \text{ mm}^2/\text{sec}$ . The declared NPSH values are laboratory values; for practical use we recommend increasing these values by 0,5 m.

## SMB.../SVE BOOSTER SETS SERIES OPERATING CHARACTERISTICS

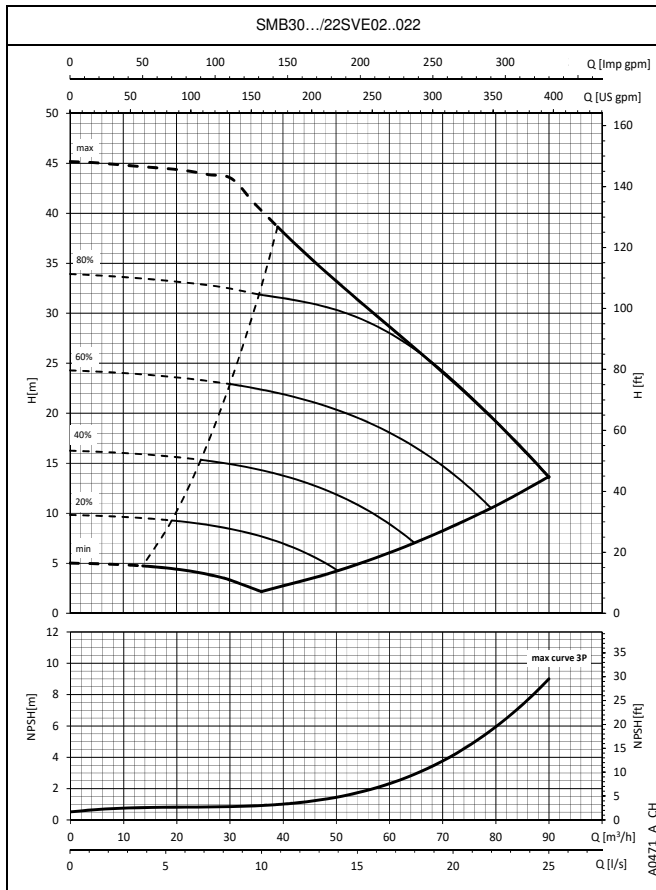
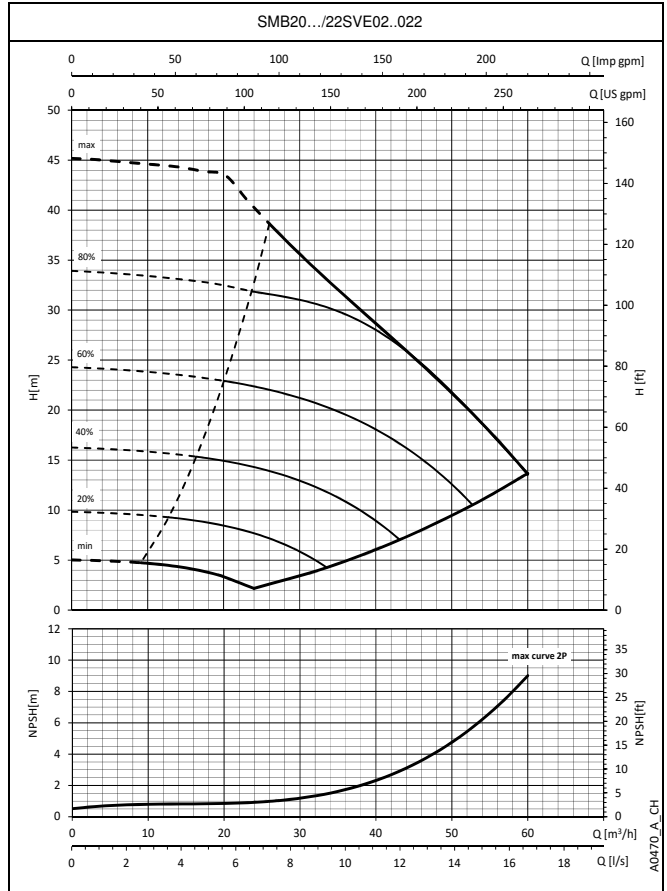
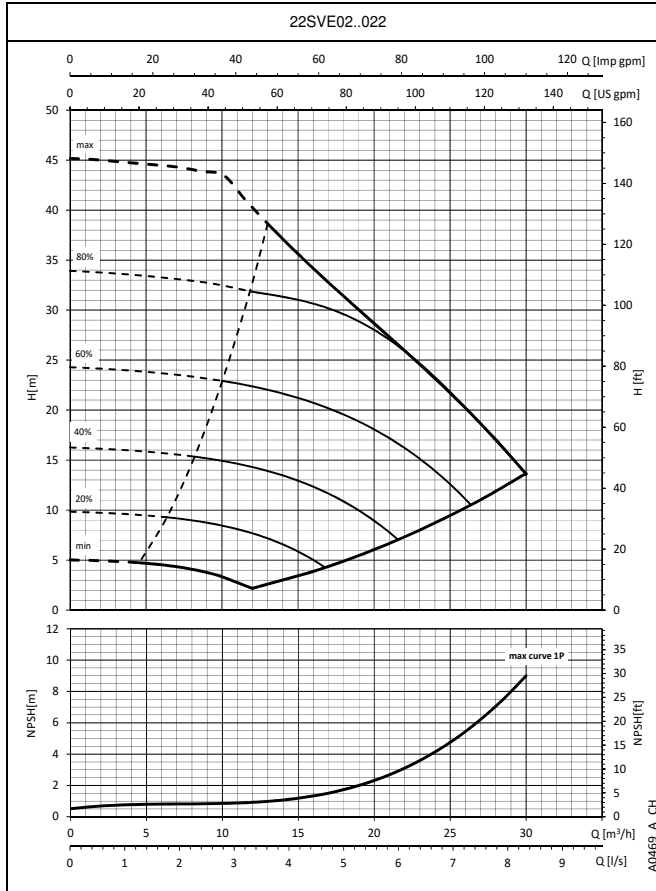

The performance curves do not take into account flow resistance in the valves and piping. The curves show the performance with one, two and three pumps running. These performances are valid for liquids with density  $\rho = 1 \text{ Kg/dm}^3$  and kinematic viscosity  $\nu = 1 \text{ mm}^2/\text{sec}$ . The declared NPSH values are laboratory values; for practical use we recommend increasing these values by 0,5 m.

## SMB.../VME BOOSTER SETS SERIES OPERATING CHARACTERISTICS

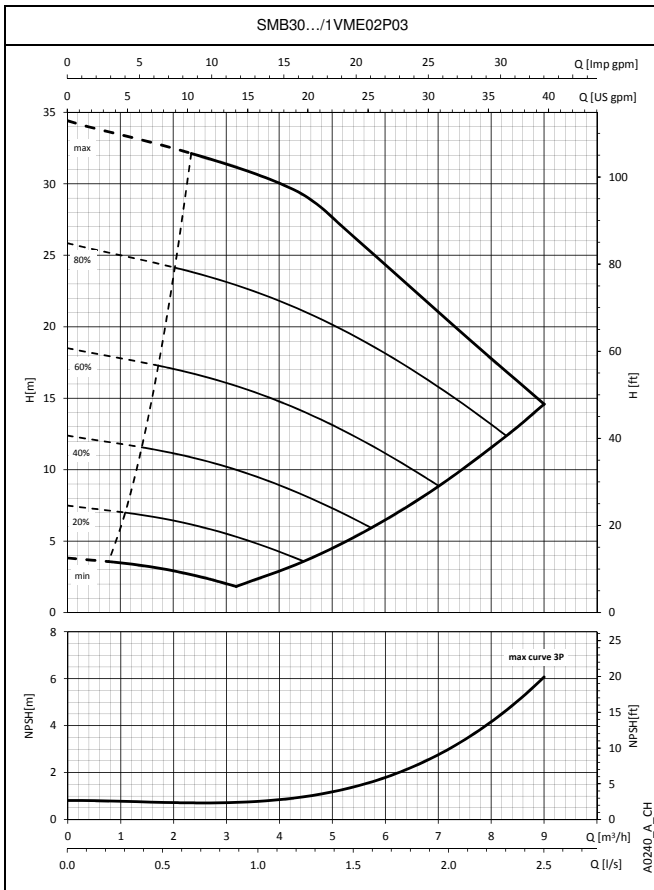
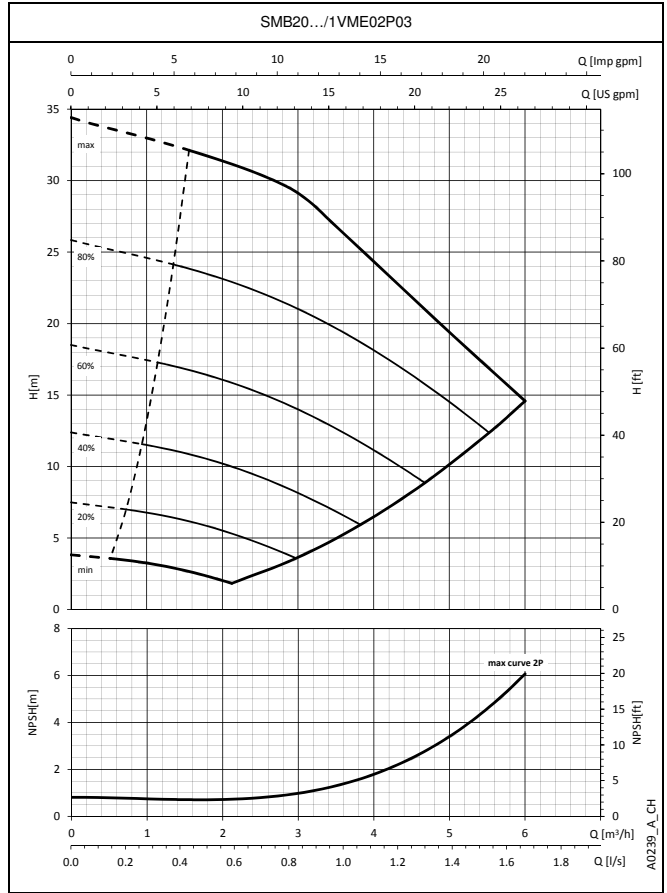
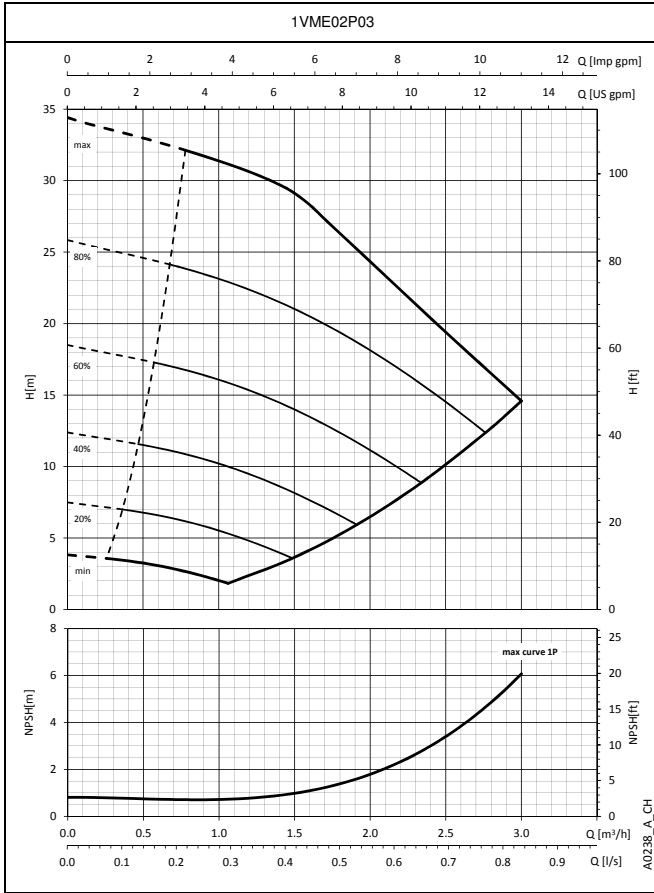

The performance curves do not take into account flow resistance in the valves and piping. The curves show the performance with one, two and three pumps running. These performances are valid for liquids with density  $\rho = 1 \text{ Kg/dm}^3$  and kinematic viscosity  $\nu = 1 \text{ mm}^2/\text{sec}$ . The declared NPSH values are laboratory values; for practical use we recommend increasing these values by 0,5 m.

## SMB.../VME BOOSTER SETS SERIES OPERATING CHARACTERISTICS

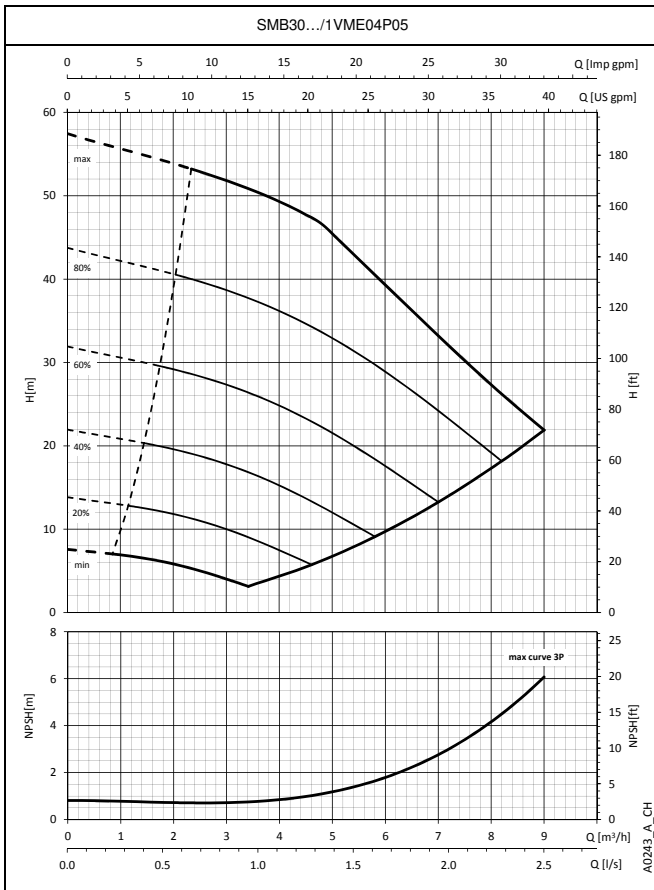
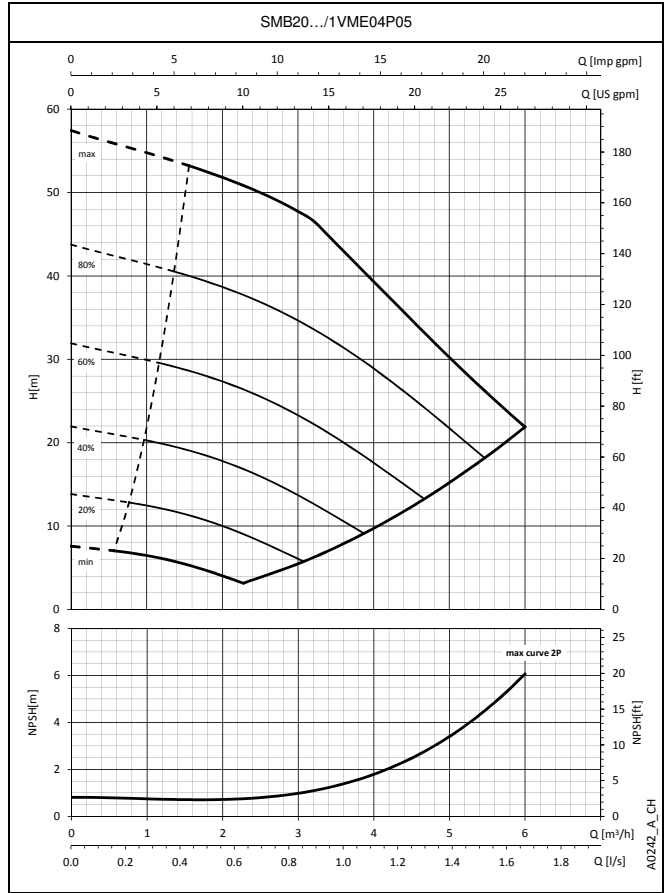
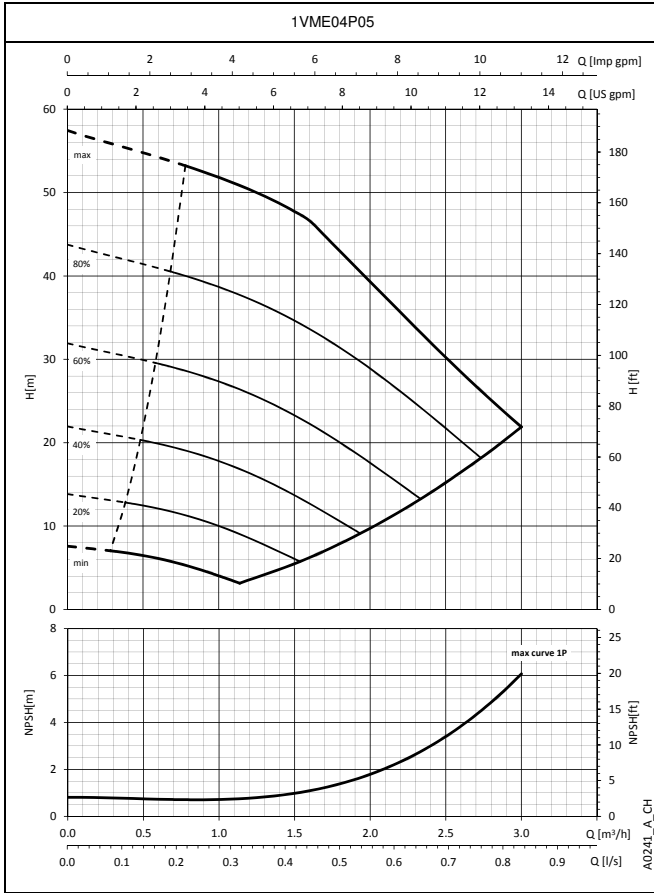

The performance curves do not take into account flow resistance in the valves and piping. The curves show the performance with one, two and three pumps running. These performances are valid for liquids with density  $\rho = 1 \text{ Kg/dm}^3$  and kinematic viscosity  $\nu = 1 \text{ mm}^2/\text{sec}$ . The declared NPSH values are laboratory values; for practical use we recommend increasing these values by 0,5 m.

## SMB.../VME BOOSTER SETS SERIES OPERATING CHARACTERISTICS

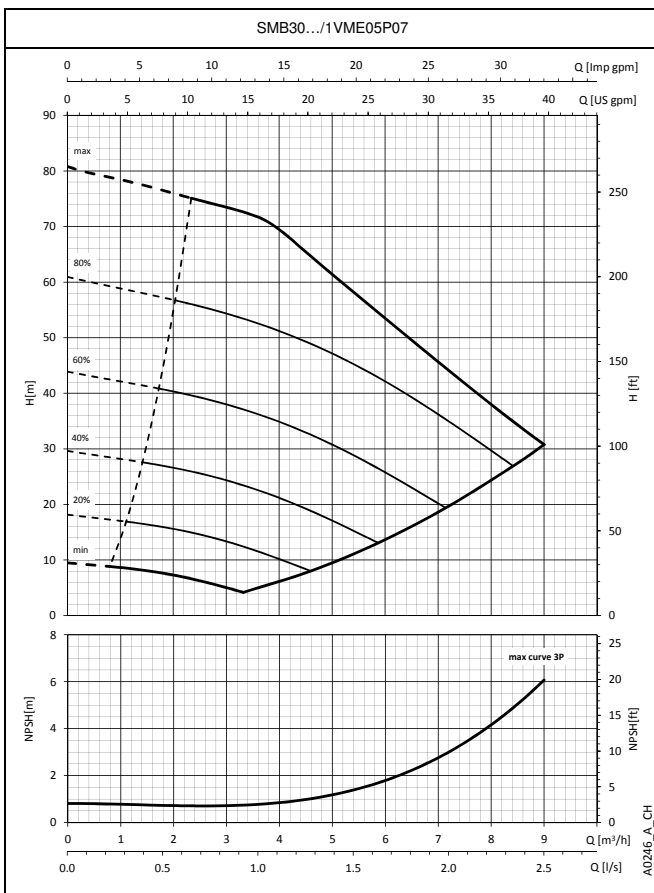
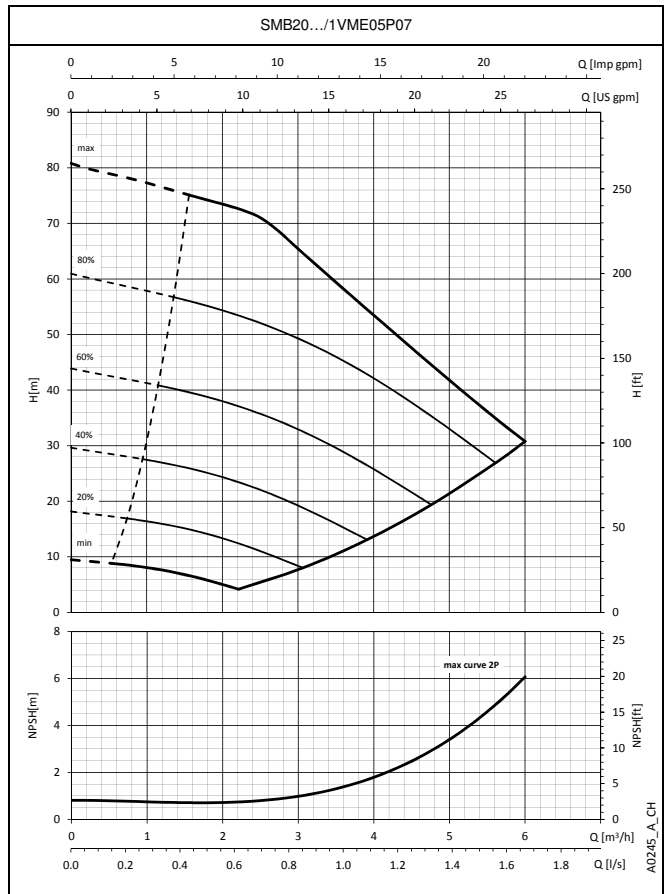
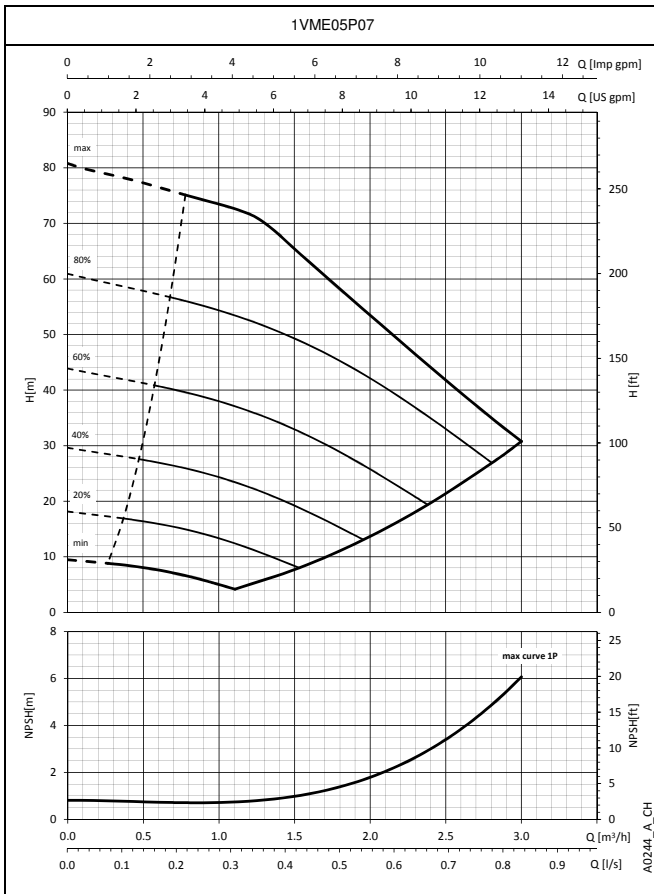

The performance curves do not take into account flow resistance in the valves and piping. The curves show the performance with one, two and three pumps running. These performances are valid for liquids with density  $\rho = 1 \text{ Kg/dm}^3$  and kinematic viscosity  $\nu = 1 \text{ mm}^2/\text{sec}$ . The declared NPSH values are laboratory values; for practical use we recommend increasing these values by 0,5 m.

## SMB.../VME BOOSTER SETS SERIES OPERATING CHARACTERISTICS

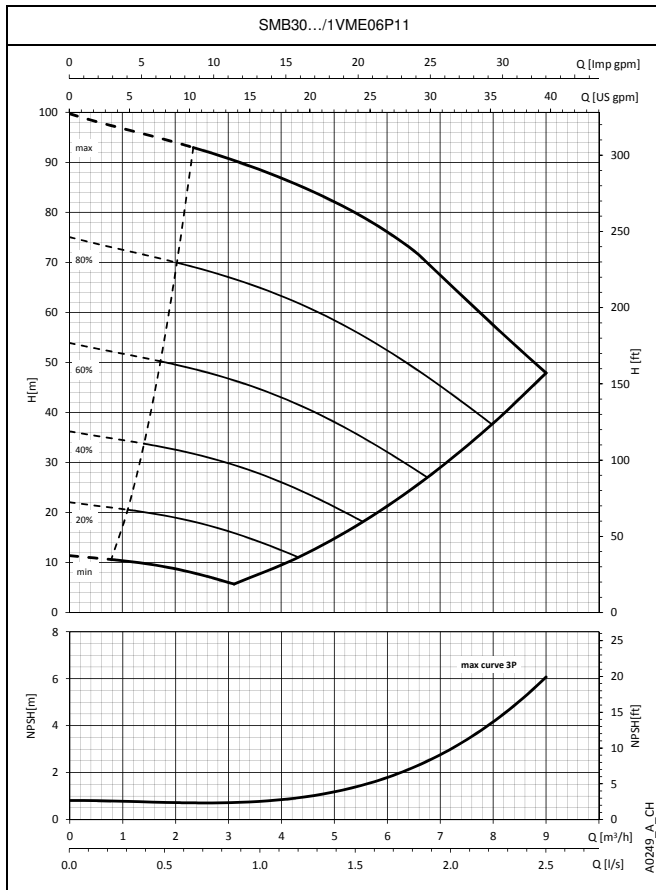
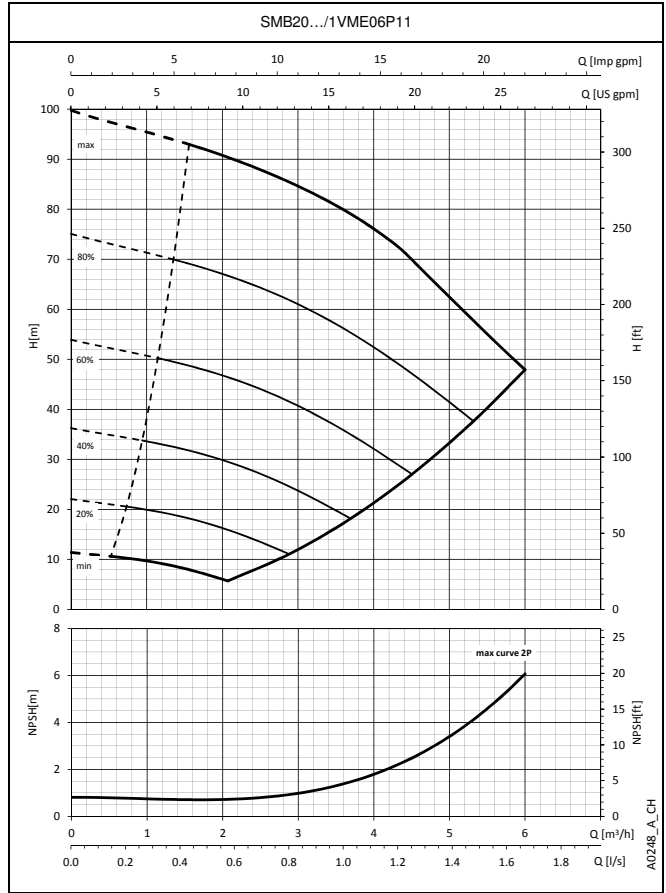
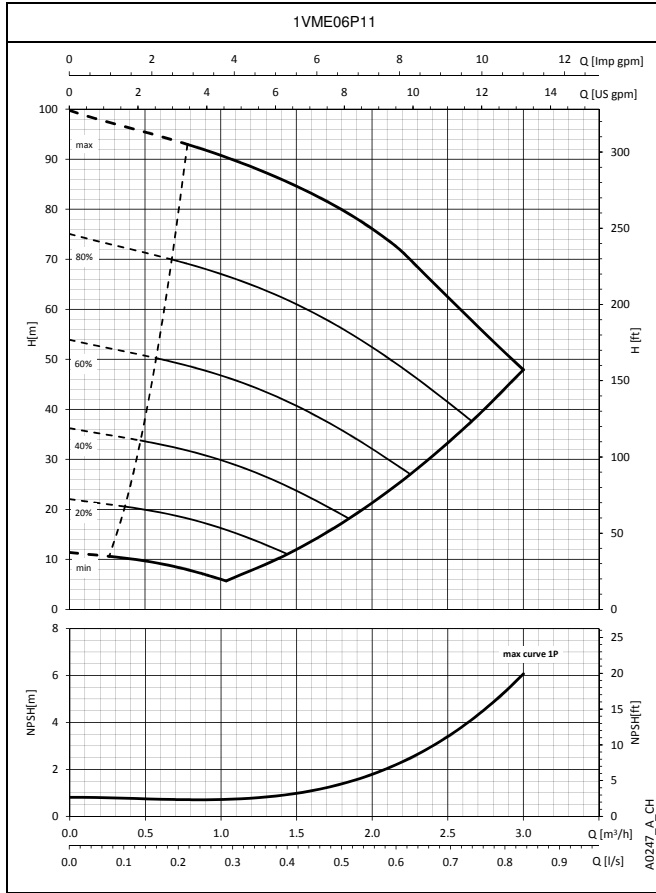

The performance curves do not take into account flow resistance in the valves and piping. The curves show the performance with one, two and three pumps running. These performances are valid for liquids with density  $\rho = 1 \text{ Kg/dm}^3$  and kinematic viscosity  $\nu = 1 \text{ mm}^2/\text{sec}$ . The declared NPSH values are laboratory values; for practical use we recommend increasing these values by 0,5 m.

## SMB.../VME BOOSTER SETS SERIES OPERATING CHARACTERISTICS

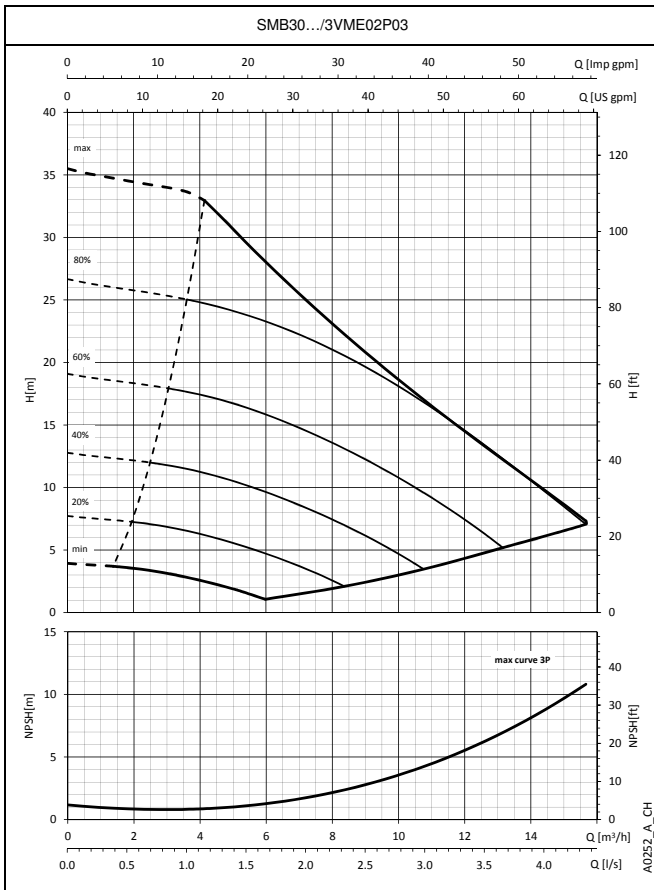
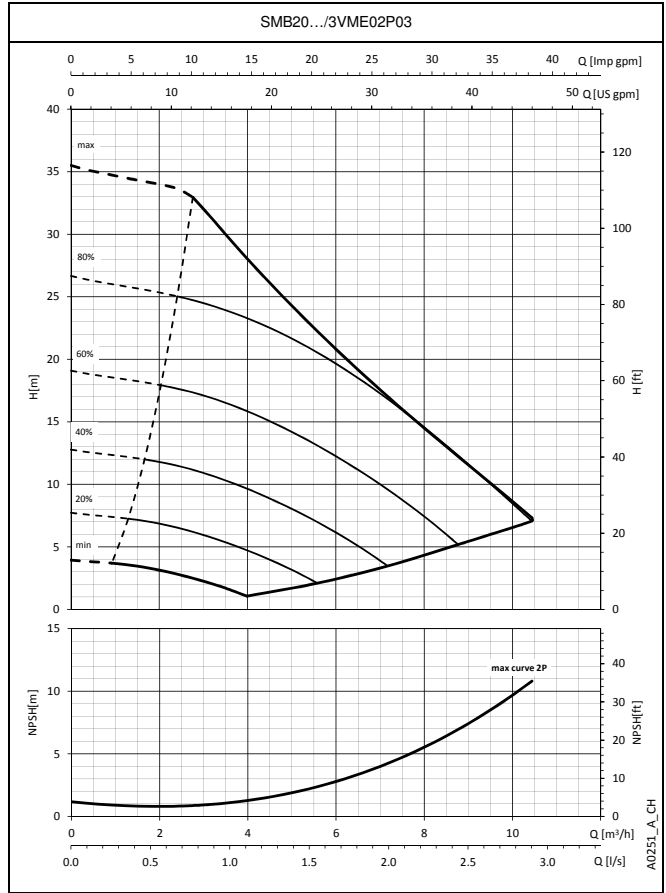
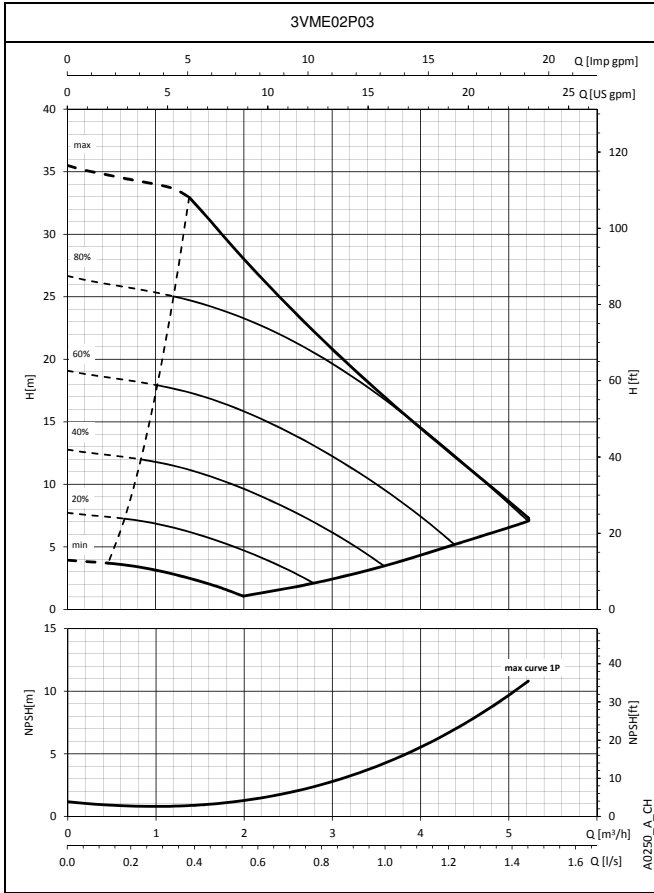

The performance curves do not take into account flow resistance in the valves and piping. The curves show the performance with one, two and three pumps running. These performances are valid for liquids with density  $\rho = 1 \text{ Kg/dm}^3$  and kinematic viscosity  $\nu = 1 \text{ mm}^2/\text{sec}$ . The declared NPSH values are laboratory values; for practical use we recommend increasing these values by 0,5 m.

## SMB.../VME BOOSTER SETS SERIES OPERATING CHARACTERISTICS

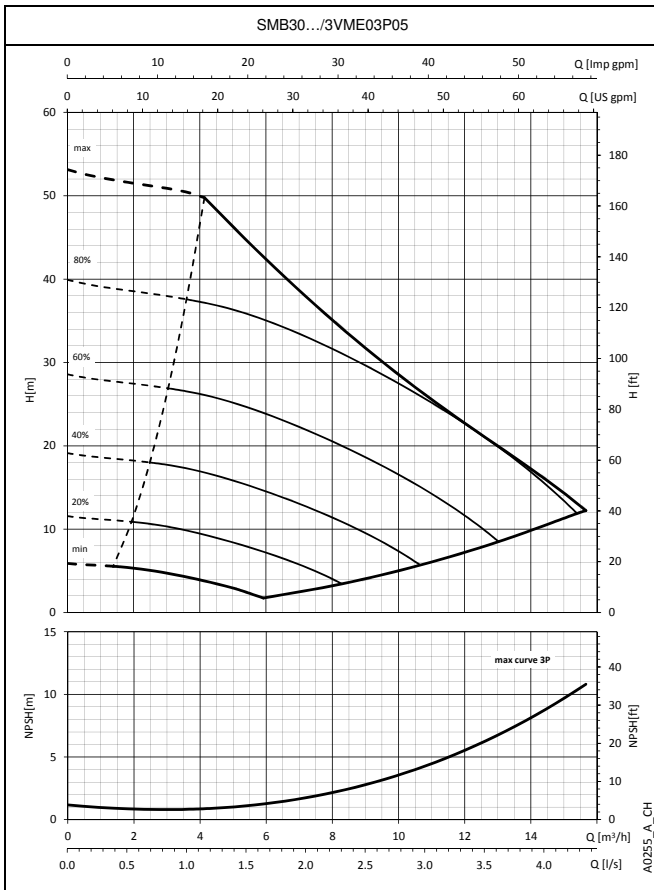
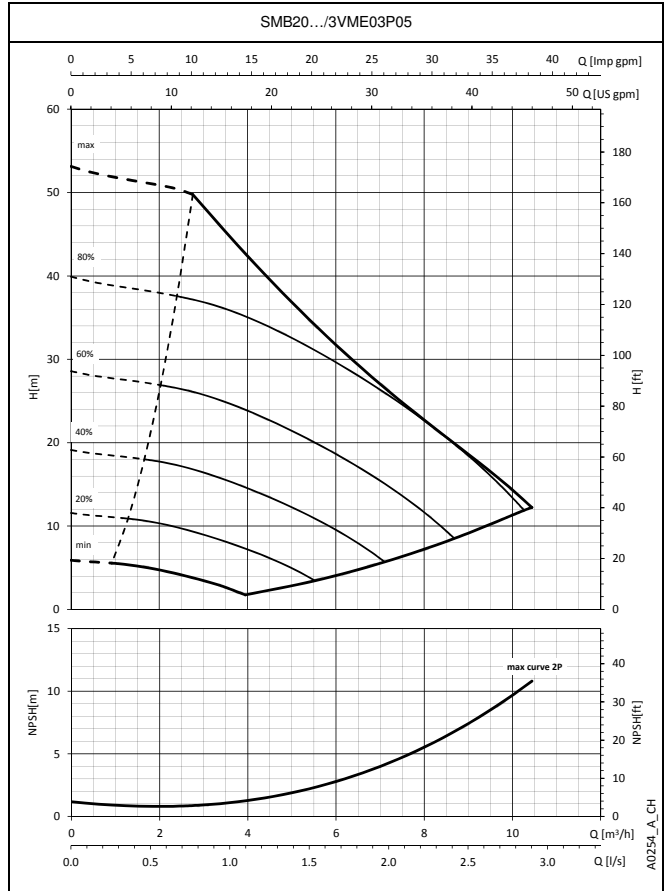
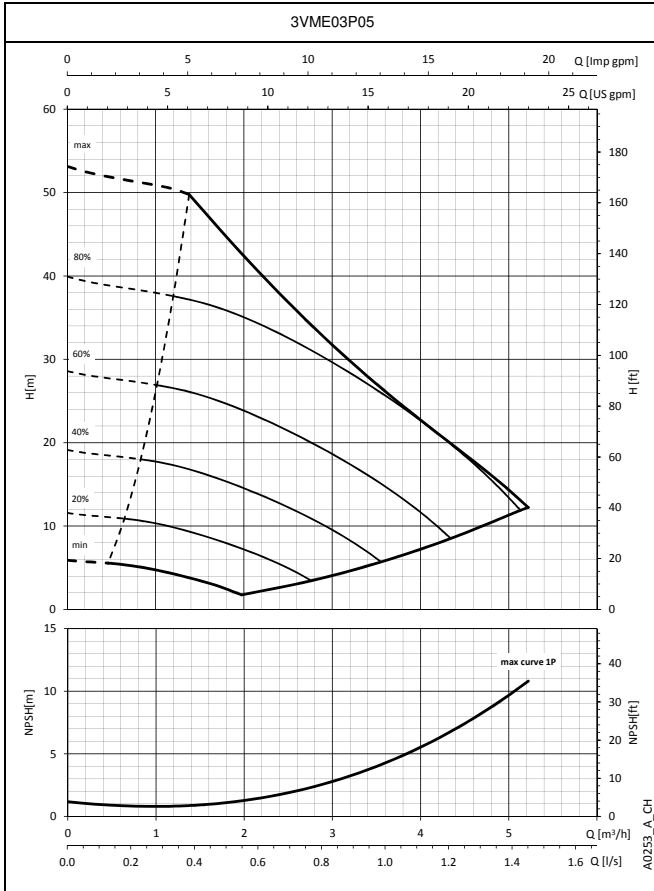

The performance curves do not take into account flow resistance in the valves and piping. The curves show the performance with one, two and three pumps running. These performances are valid for liquids with density  $\rho = 1 \text{ Kg/dm}^3$  and kinematic viscosity  $\nu = 1 \text{ mm}^2/\text{sec}$ . The declared NPSH values are laboratory values; for practical use we recommend increasing these values by 0,5 m.

## SMB.../VME BOOSTER SETS SERIES OPERATING CHARACTERISTICS

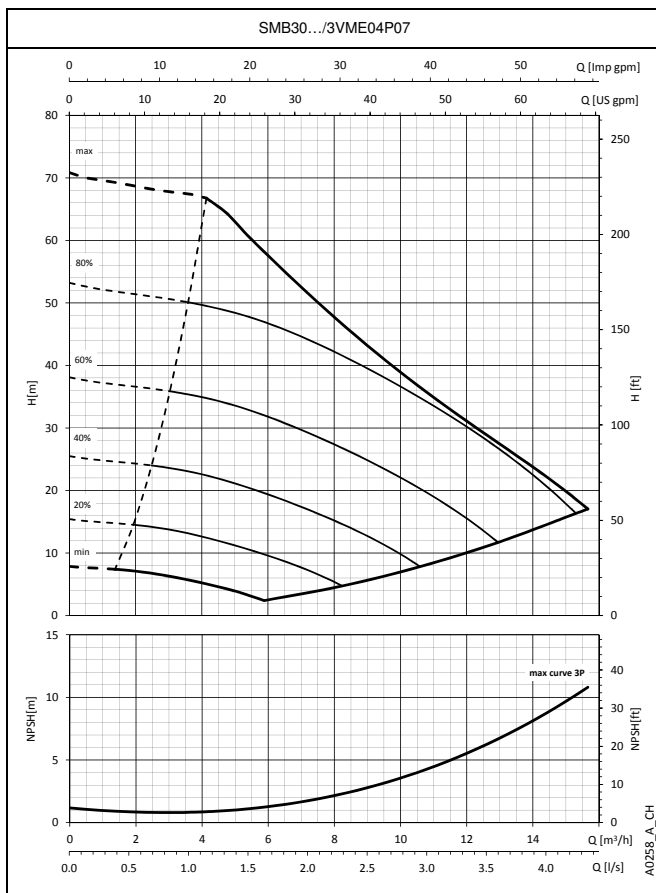
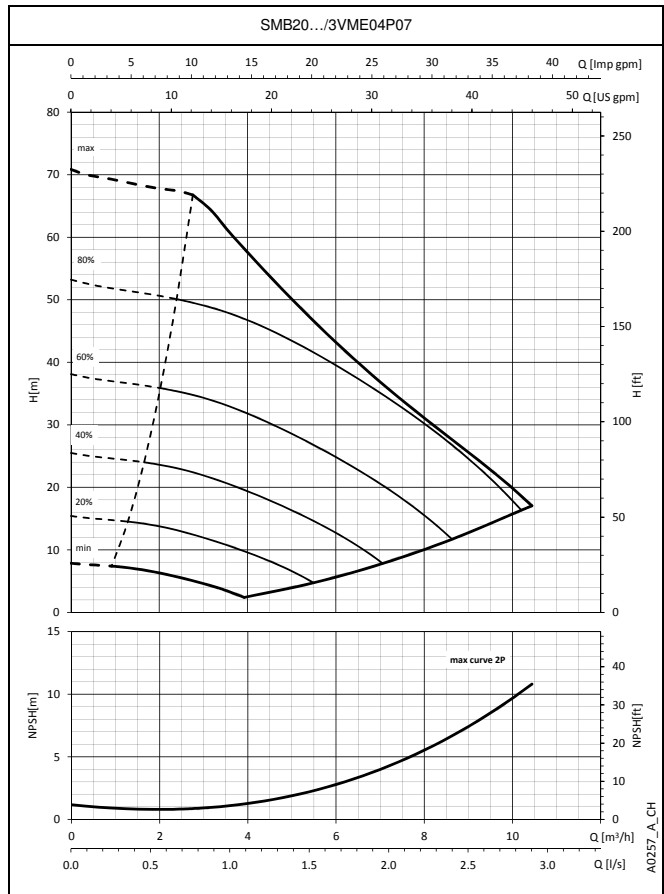
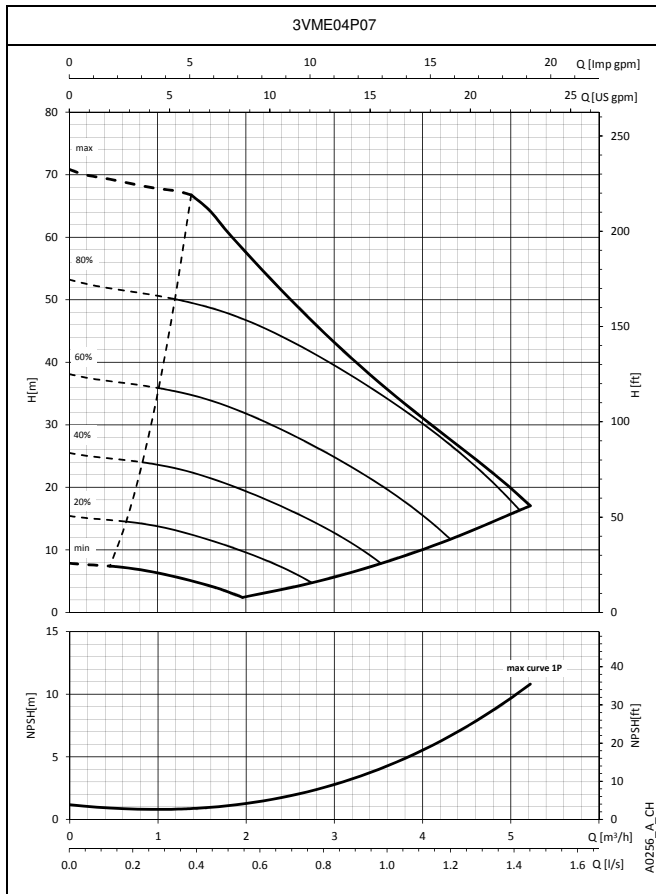

The performance curves do not take into account flow resistance in the valves and piping. The curves show the performance with one, two and three pumps running. These performances are valid for liquids with density  $\rho = 1 \text{ Kg/dm}^3$  and kinematic viscosity  $\nu = 1 \text{ mm}^2/\text{sec}$ . The declared NPSH values are laboratory values; for practical use we recommend increasing these values by 0,5 m.

## SMB.../VME BOOSTER SETS SERIES OPERATING CHARACTERISTICS

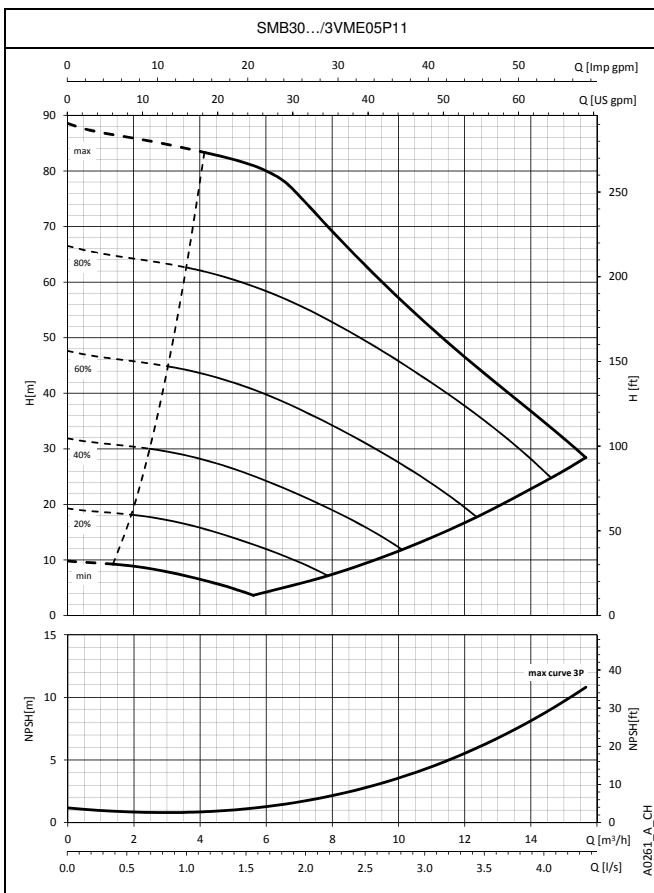
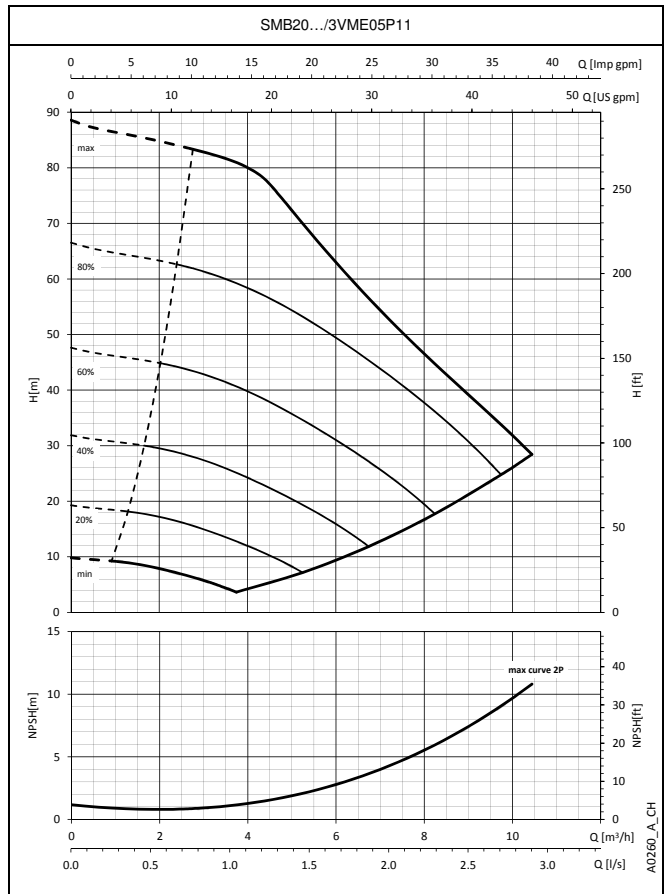
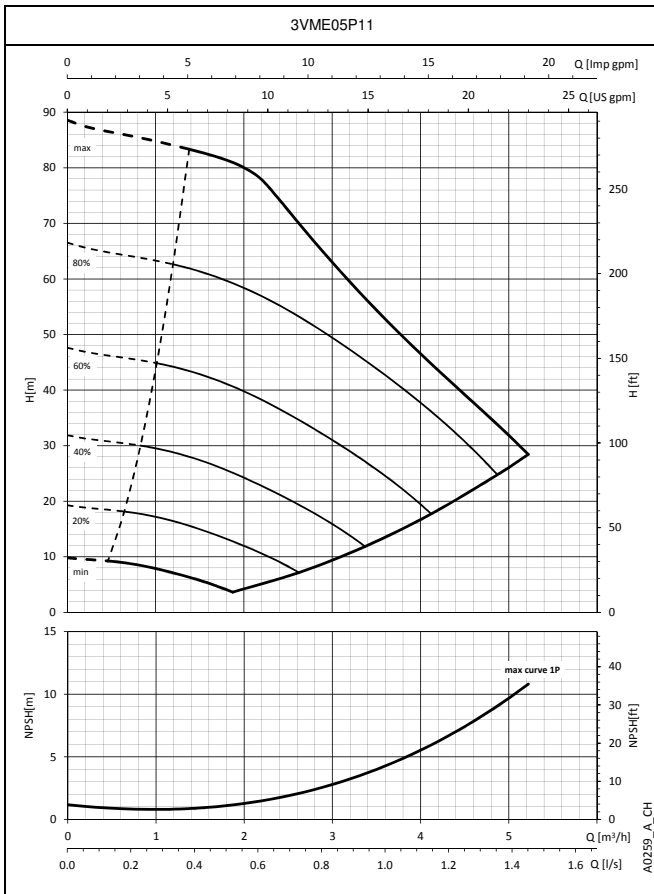

The performance curves do not take into account flow resistance in the valves and piping. The curves show the performance with one, two and three pumps running. These performances are valid for liquids with density  $\rho = 1 \text{ Kg/dm}^3$  and kinematic viscosity  $\nu = 1 \text{ mm}^2/\text{sec}$ . The declared NPSH values are laboratory values; for practical use we recommend increasing these values by 0,5 m.

## SMB.../VME BOOSTER SETS SERIES OPERATING CHARACTERISTICS

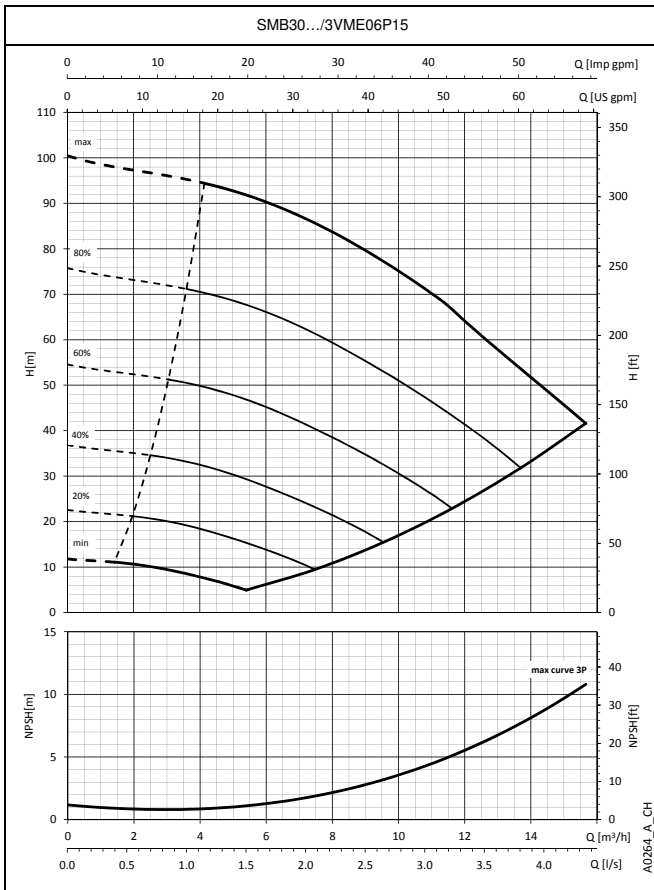
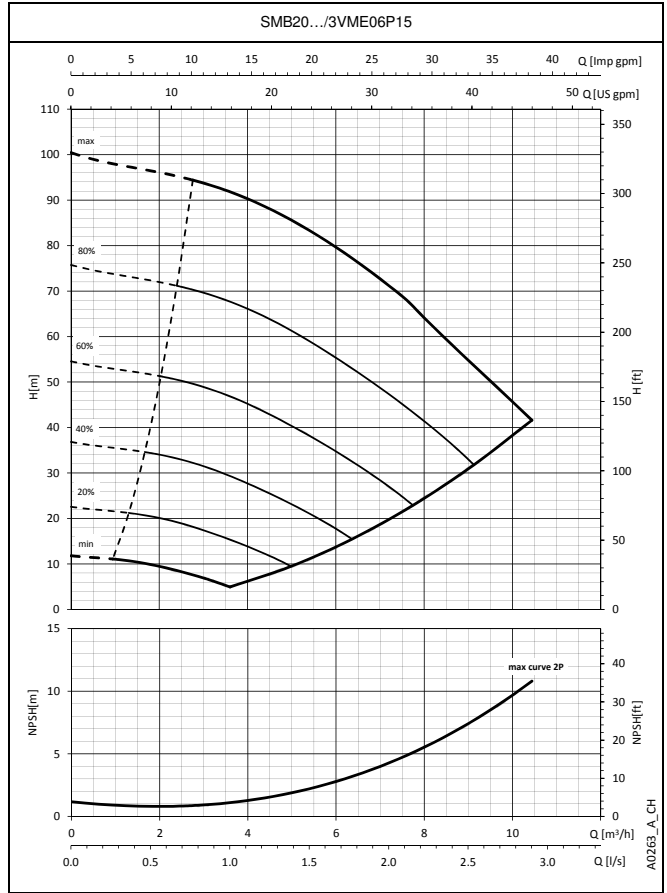
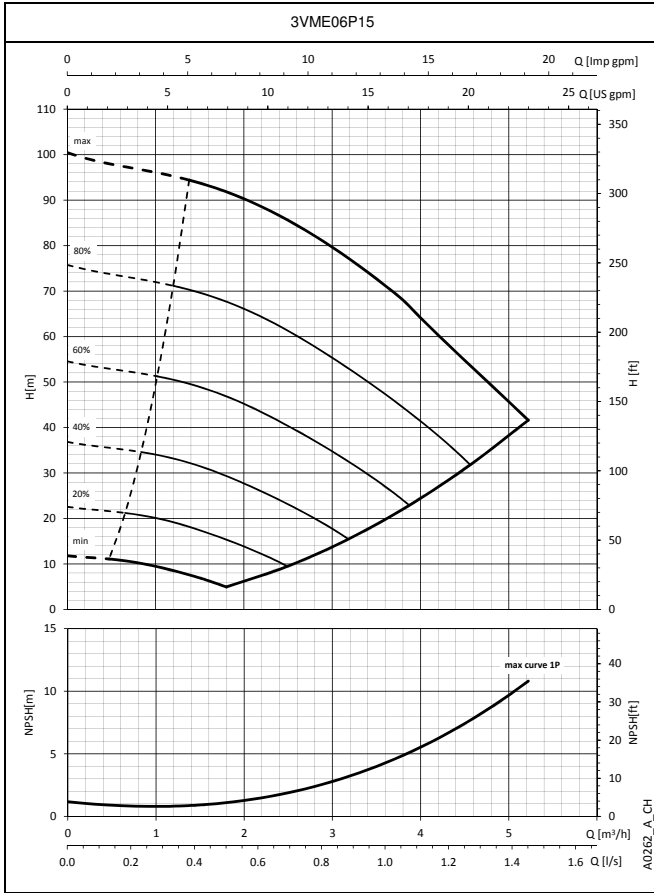

The performance curves do not take into account flow resistance in the valves and piping. The curves show the performance with one, two and three pumps running. These performances are valid for liquids with density  $\rho = 1 \text{ Kg/dm}^3$  and kinematic viscosity  $\nu = 1 \text{ mm}^2/\text{sec}$ . The declared NPSH values are laboratory values; for practical use we recommend increasing these values by 0,5 m.

## SMB.../VME BOOSTER SETS SERIES OPERATING CHARACTERISTICS

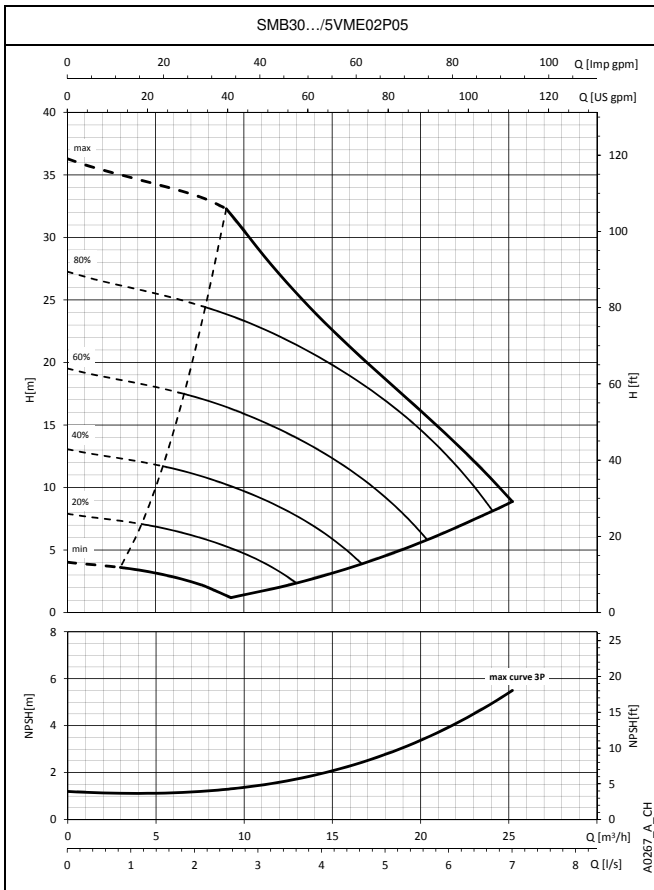
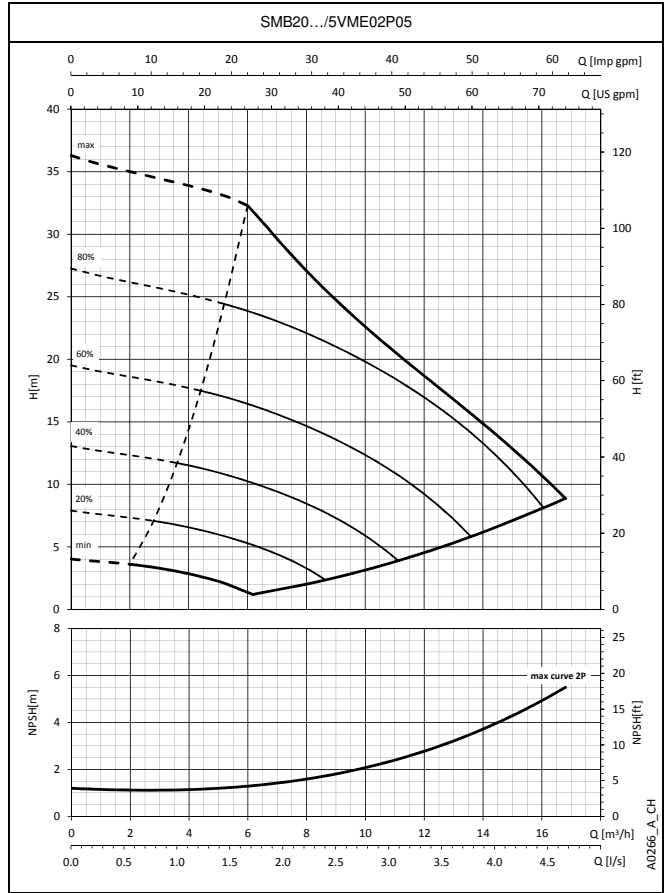
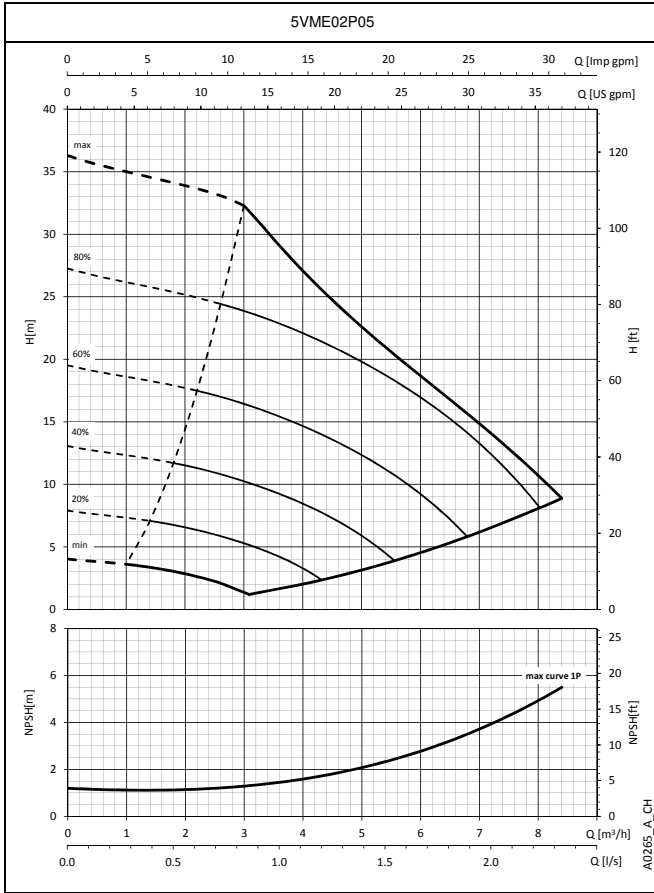

The performance curves do not take into account flow resistance in the valves and piping. The curves show the performance with one, two and three pumps running. These performances are valid for liquids with density  $\rho = 1 \text{ Kg/dm}^3$  and kinematic viscosity  $\nu = 1 \text{ mm}^2/\text{sec}$ . The declared NPSH values are laboratory values; for practical use we recommend increasing these values by 0,5 m.

## SMB.../VME BOOSTER SETS SERIES OPERATING CHARACTERISTICS

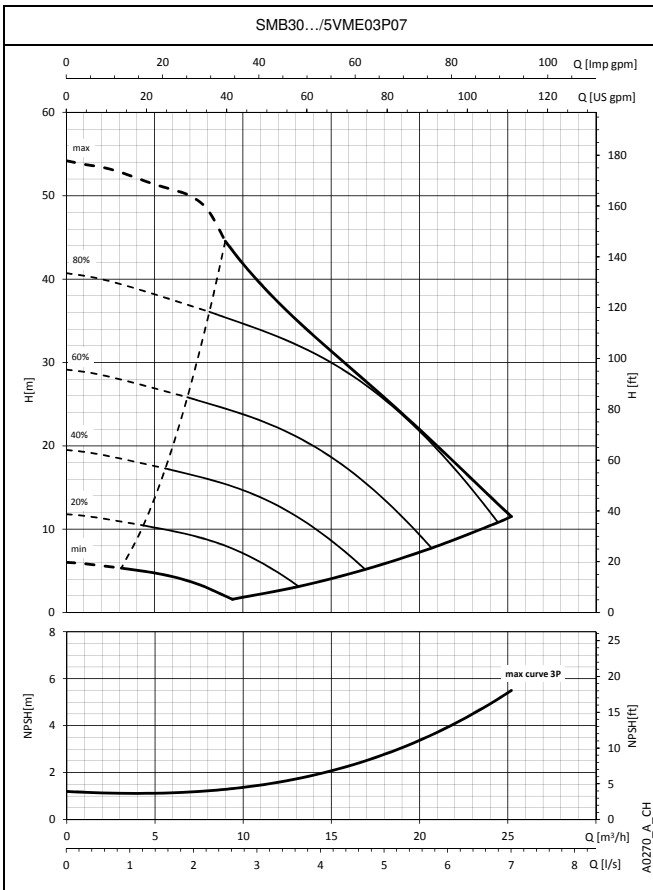
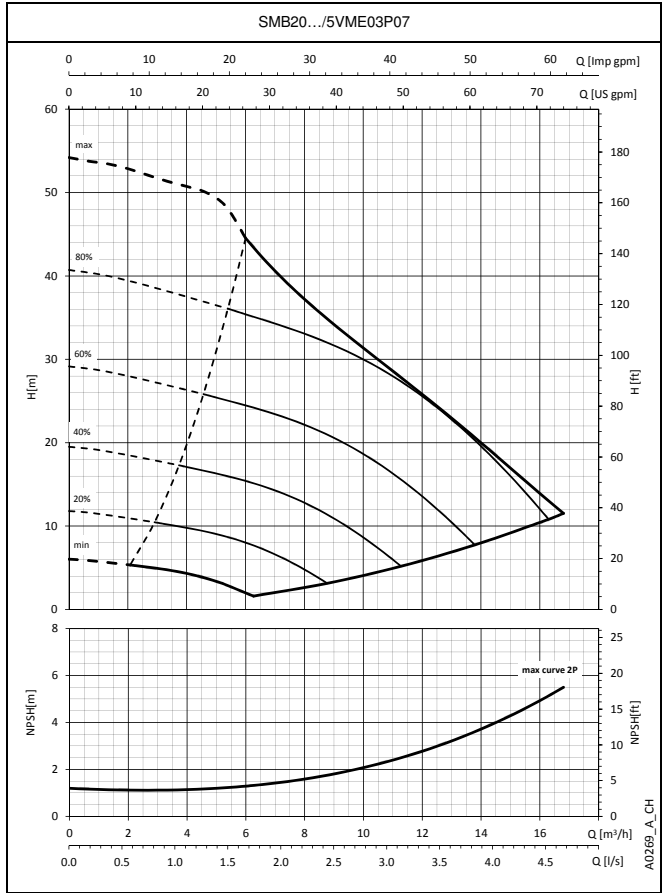
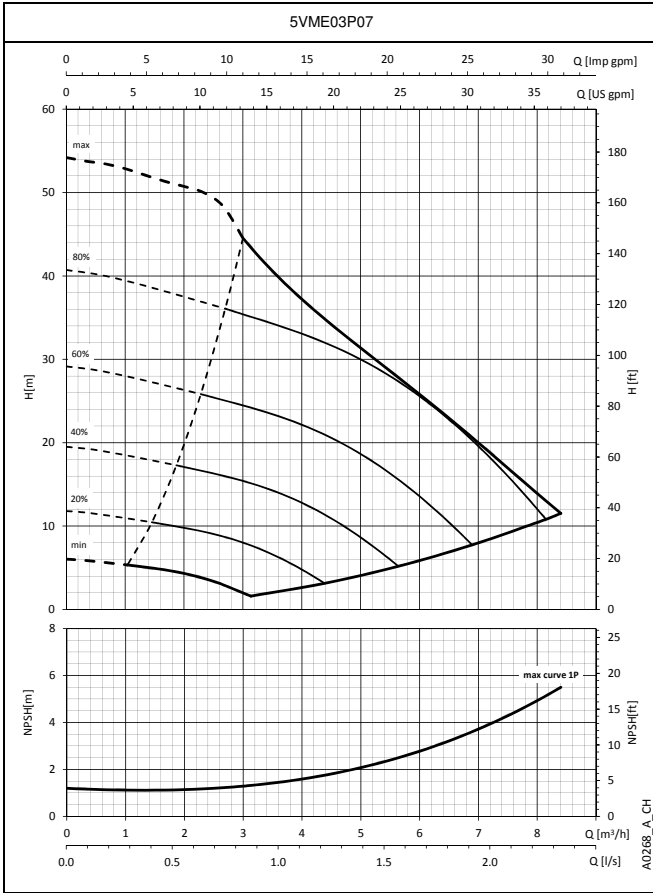

The performance curves do not take into account flow resistance in the valves and piping. The curves show the performance with one, two and three pumps running. These performances are valid for liquids with density  $\rho = 1 \text{ Kg/dm}^3$  and kinematic viscosity  $\nu = 1 \text{ mm}^2/\text{sec}$ . The declared NPSH values are laboratory values; for practical use we recommend increasing these values by 0,5 m.

## SMB.../VME BOOSTER SETS SERIES OPERATING CHARACTERISTICS

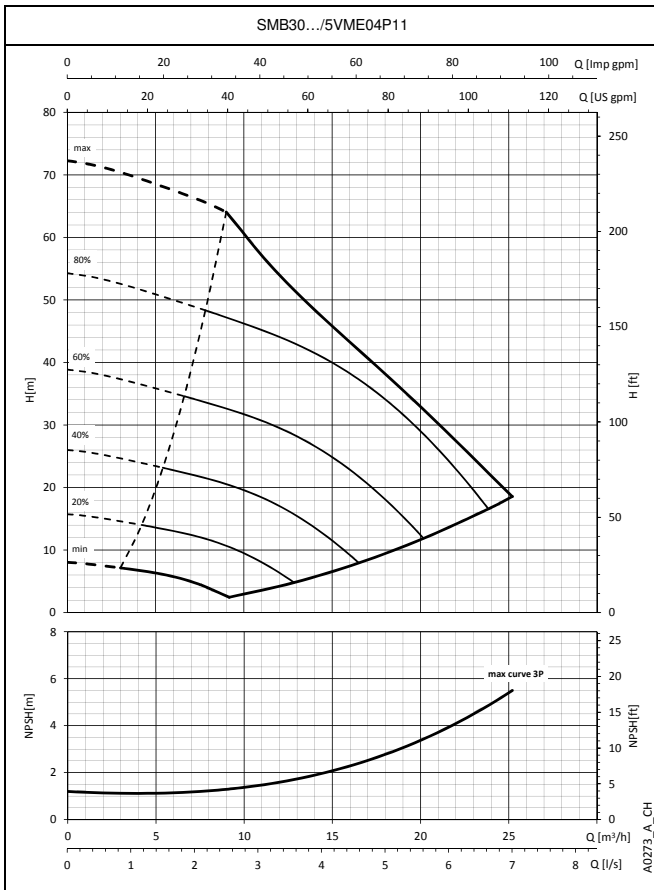
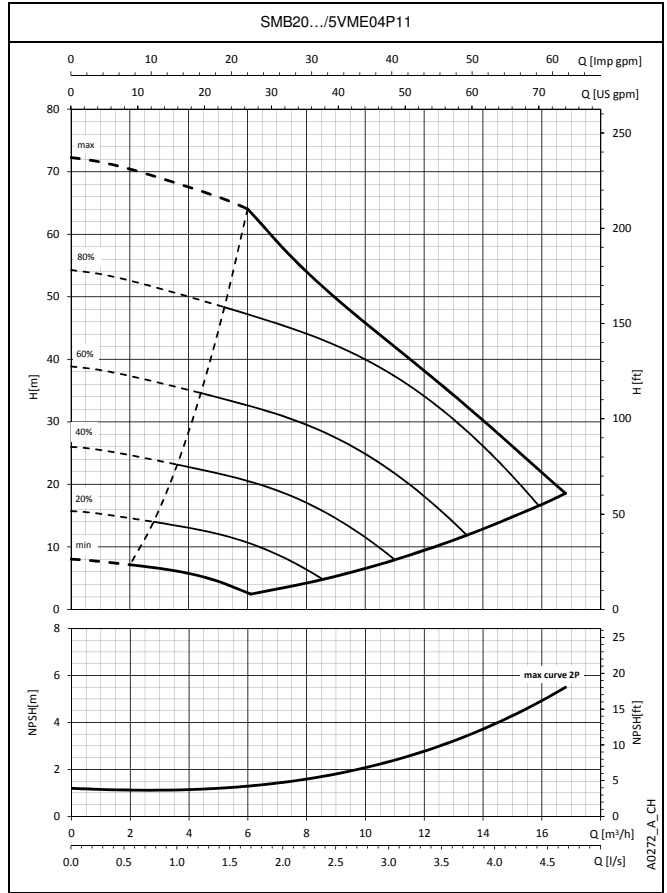
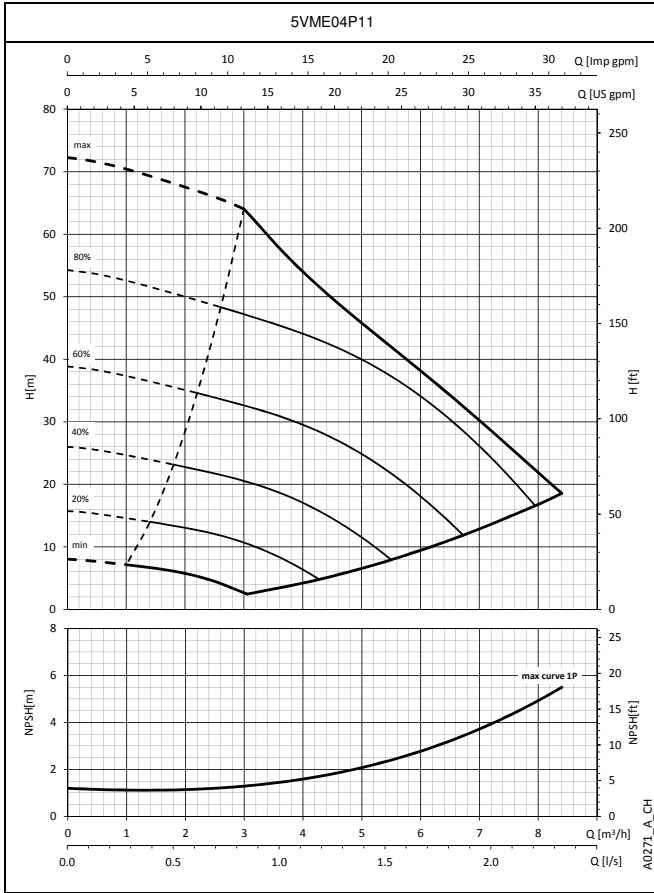

The performance curves do not take into account flow resistance in the valves and piping. The curves show the performance with one, two and three pumps running. These performances are valid for liquids with density  $\rho = 1 \text{ Kg/dm}^3$  and kinematic viscosity  $\nu = 1 \text{ mm}^2/\text{sec}$ . The declared NPSH values are laboratory values; for practical use we recommend increasing these values by 0,5 m.

## SMB.../VME BOOSTER SETS SERIES OPERATING CHARACTERISTICS

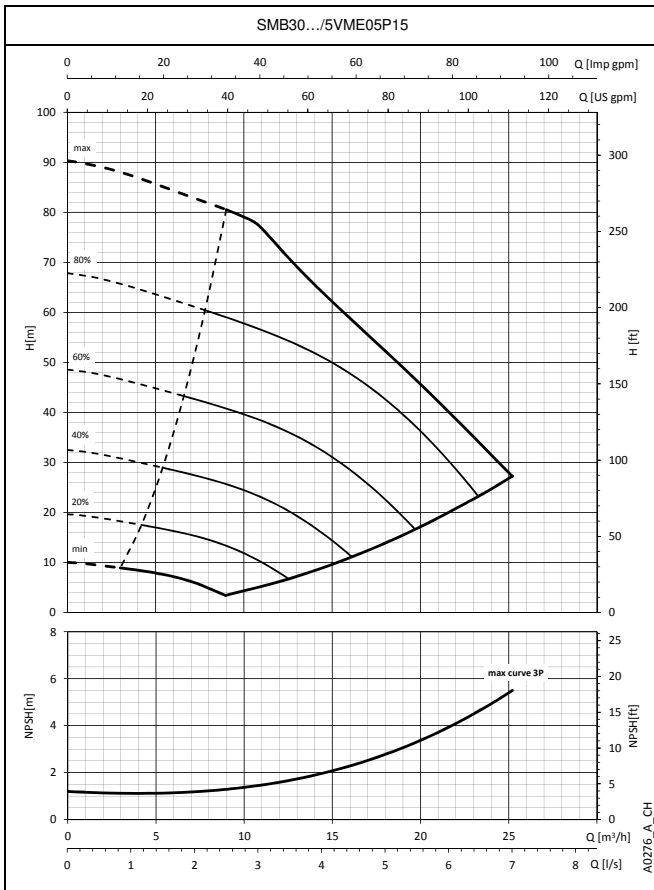
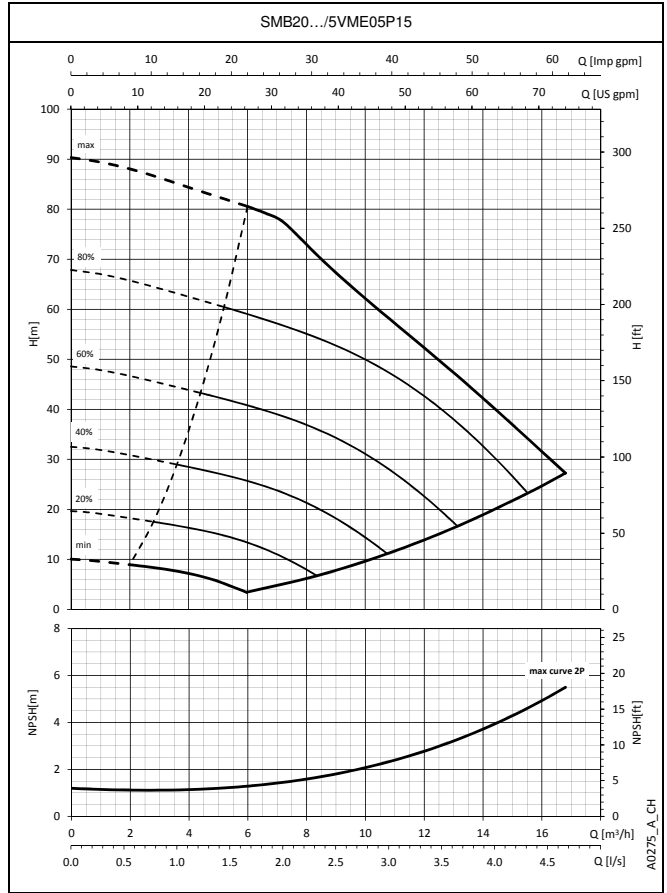
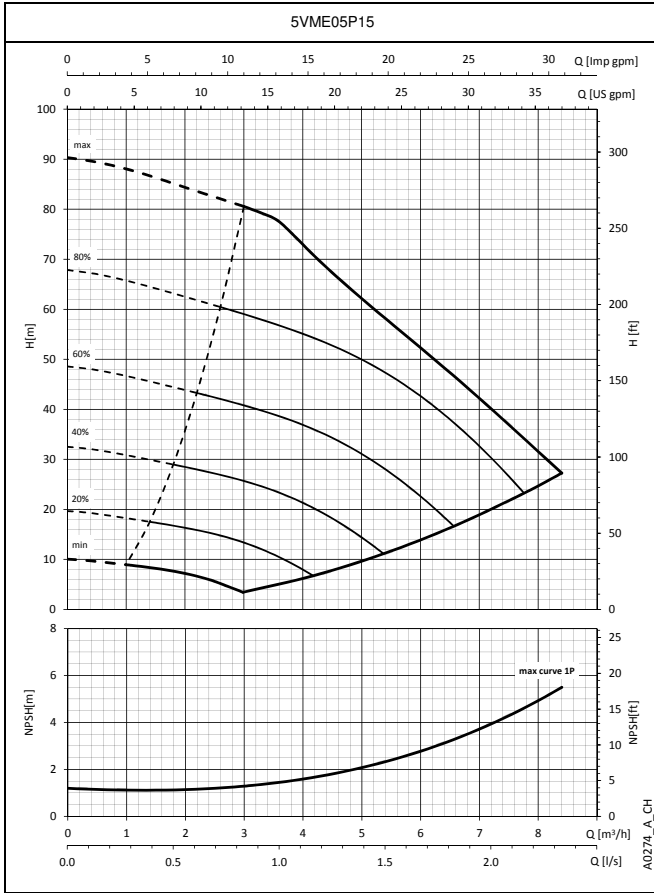

The performance curves do not take into account flow resistance in the valves and piping. The curves show the performance with one, two and three pumps running. These performances are valid for liquids with density  $\rho = 1 \text{ Kg/dm}^3$  and kinematic viscosity  $\nu = 1 \text{ mm}^2/\text{sec}$ . The declared NPSH values are laboratory values; for practical use we recommend increasing these values by 0,5 m.

## SMB.../VME BOOSTER SETS SERIES OPERATING CHARACTERISTICS

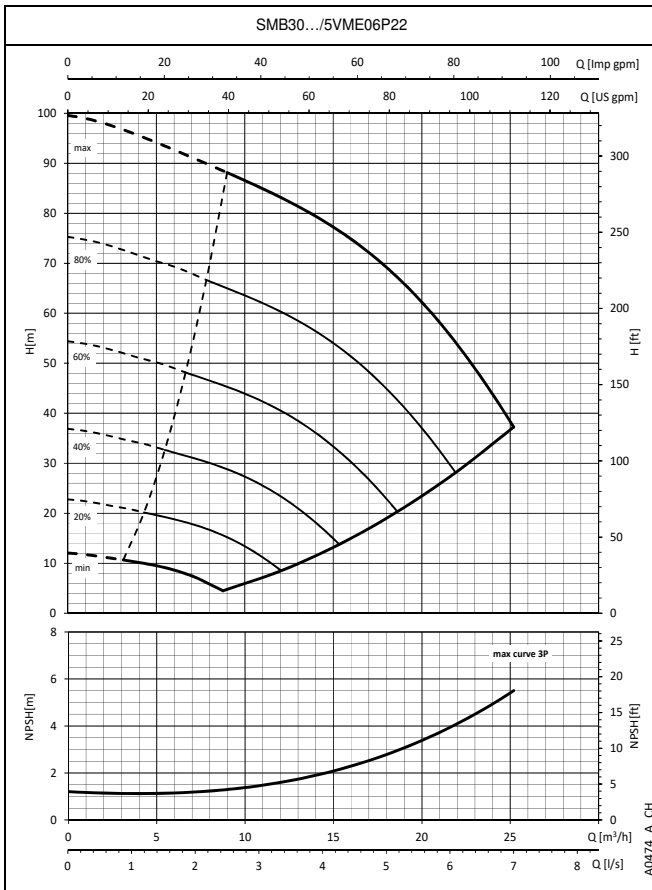
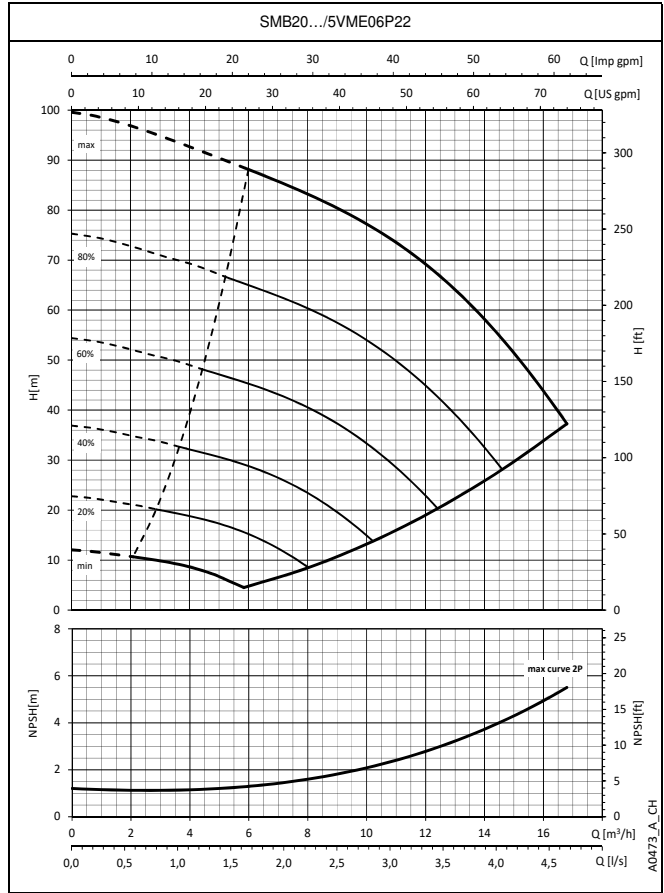
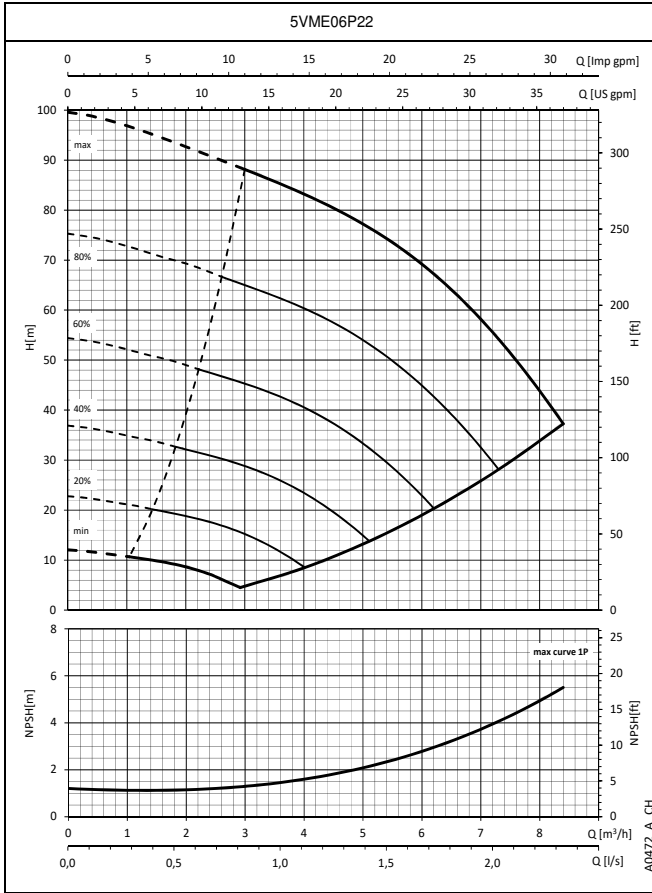

The performance curves do not take into account flow resistance in the valves and piping. The curves show the performance with one, two and three pumps running. These performances are valid for liquids with density  $\rho = 1 \text{ Kg/dm}^3$  and kinematic viscosity  $\nu = 1 \text{ mm}^2/\text{sec}$ . The declared NPSH values are laboratory values; for practical use we recommend increasing these values by 0,5 m.

## SMB.../VME BOOSTER SETS SERIES OPERATING CHARACTERISTICS

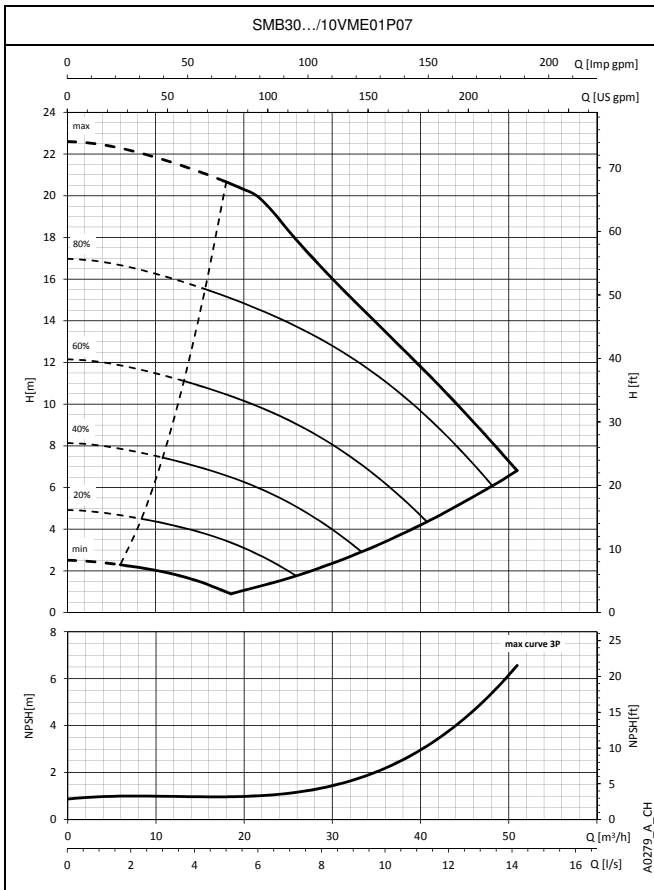
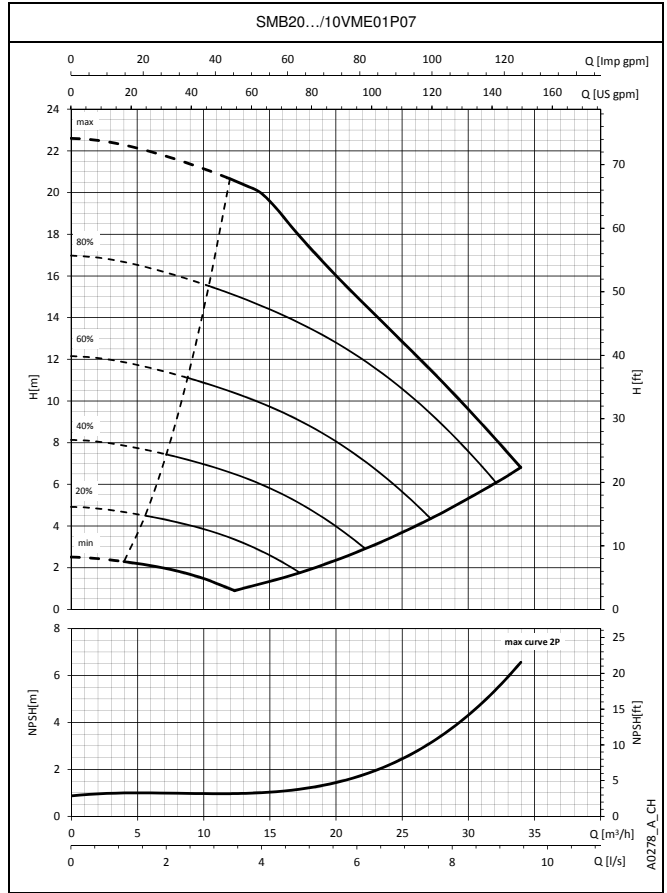
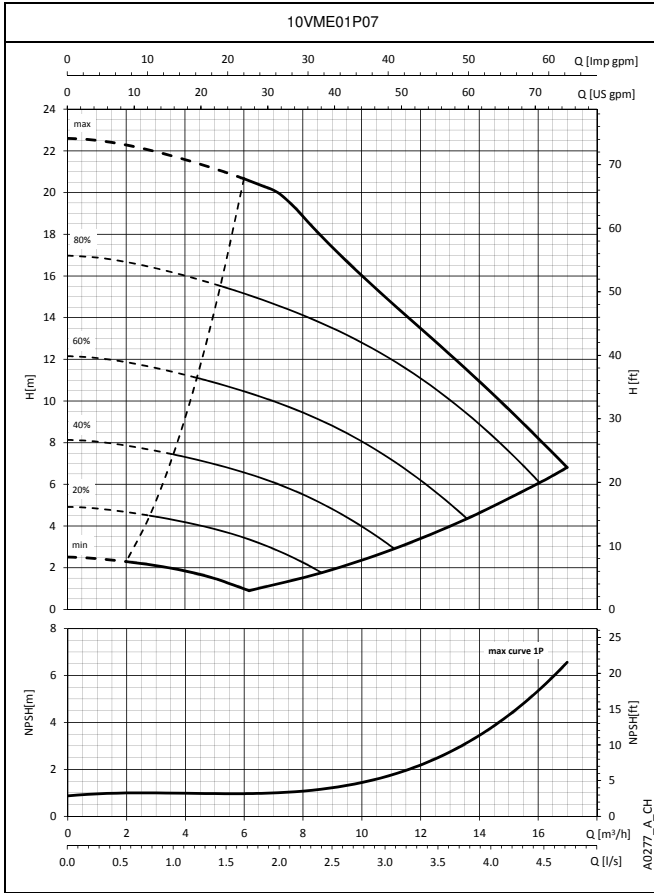

The performance curves do not take into account flow resistance in the valves and piping. The curves show the performance with one, two and three pumps running. These performances are valid for liquids with density  $\rho = 1 \text{ Kg/dm}^3$  and kinematic viscosity  $\nu = 1 \text{ mm}^2/\text{sec}$ . The declared NPSH values are laboratory values; for practical use we recommend increasing these values by 0,5 m.

## SMB.../VME BOOSTER SETS SERIES OPERATING CHARACTERISTICS

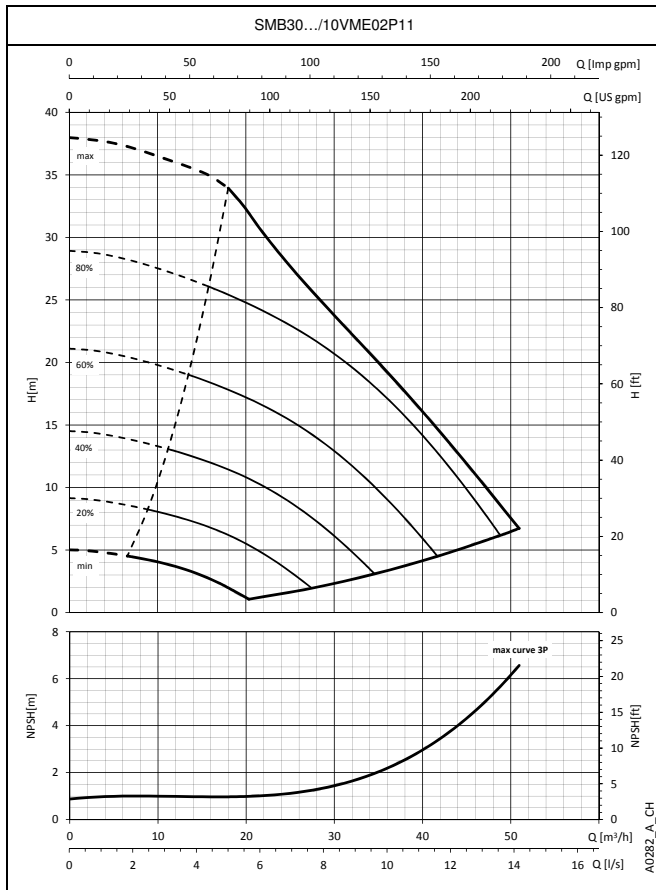
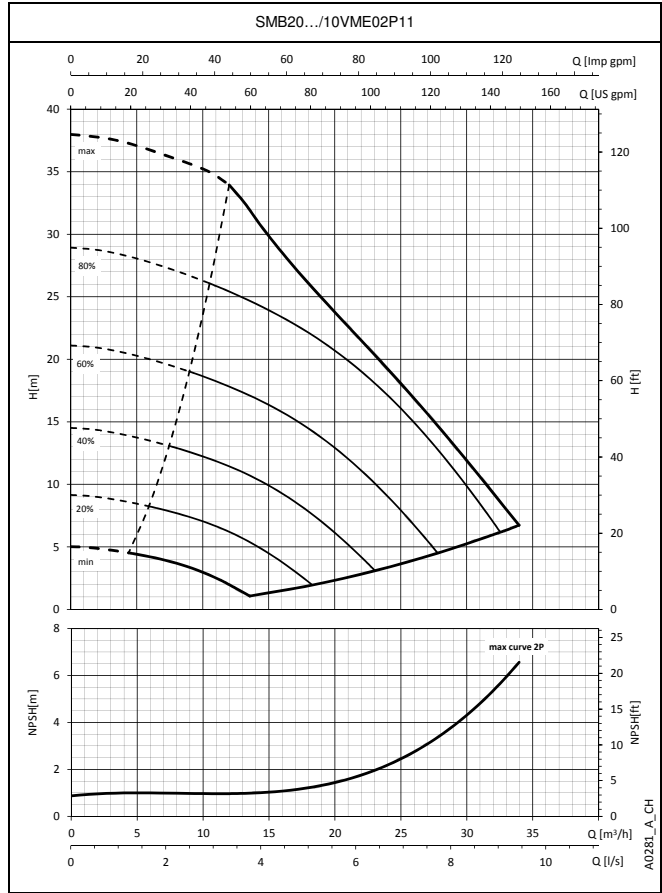
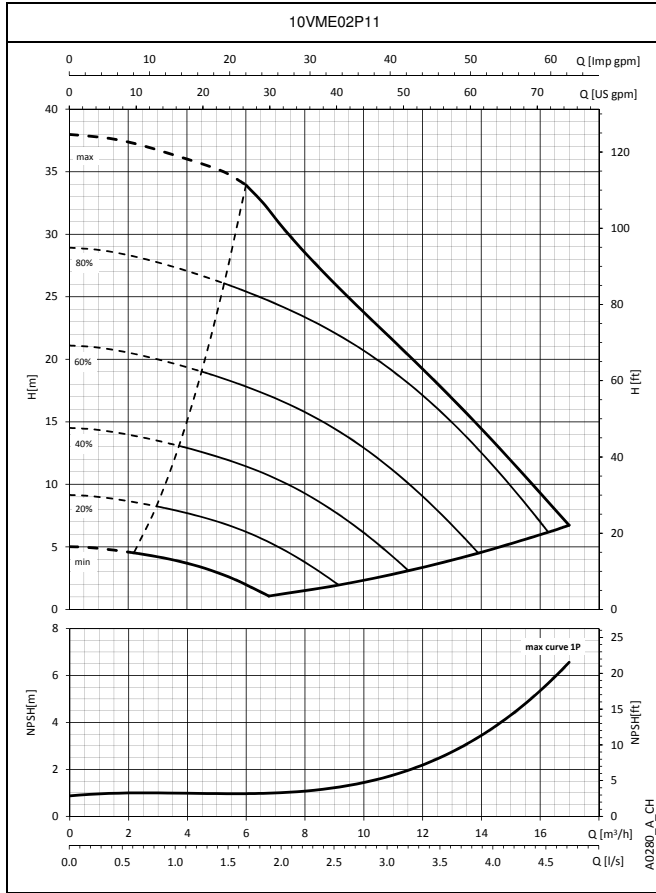

The performance curves do not take into account flow resistance in the valves and piping. The curves show the performance with one, two and three pumps running. These performances are valid for liquids with density  $\rho = 1 \text{ Kg/dm}^3$  and kinematic viscosity  $\nu = 1 \text{ mm}^2/\text{sec}$ . The declared NPSH values are laboratory values; for practical use we recommend increasing these values by 0,5 m.

**SMB.../HME BOOSTER SETS SERIES  
OPERATING CHARACTERISTICS**

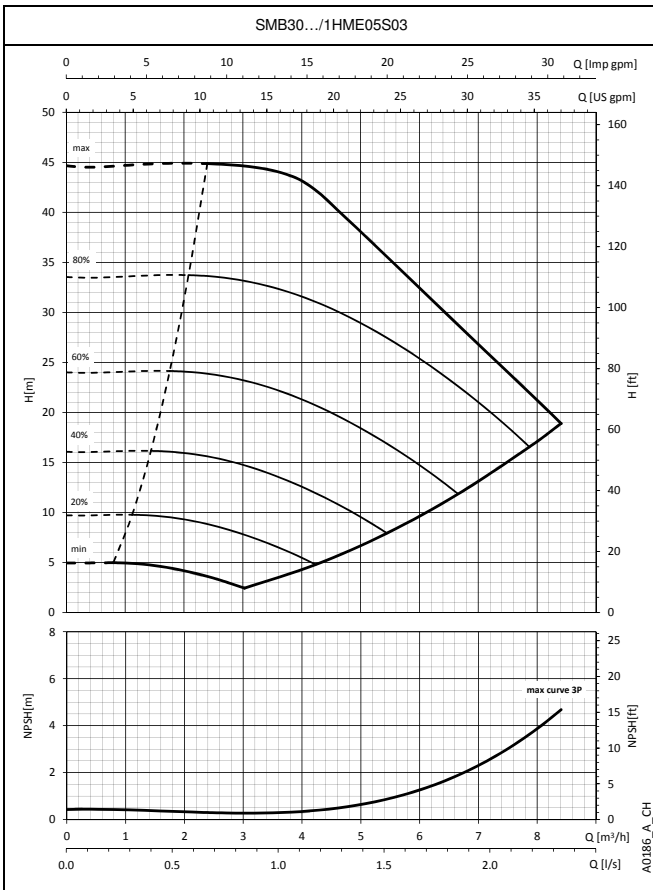
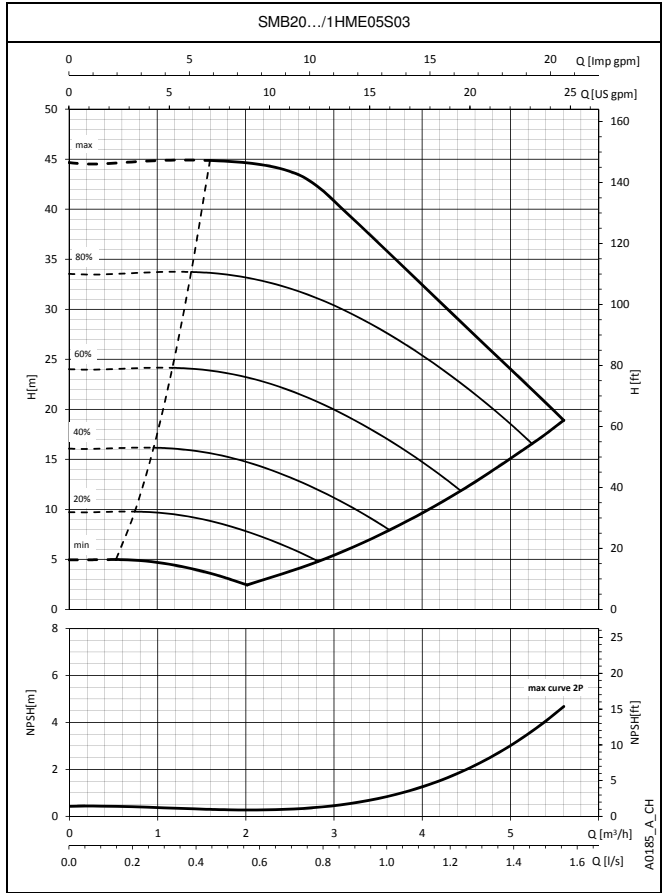
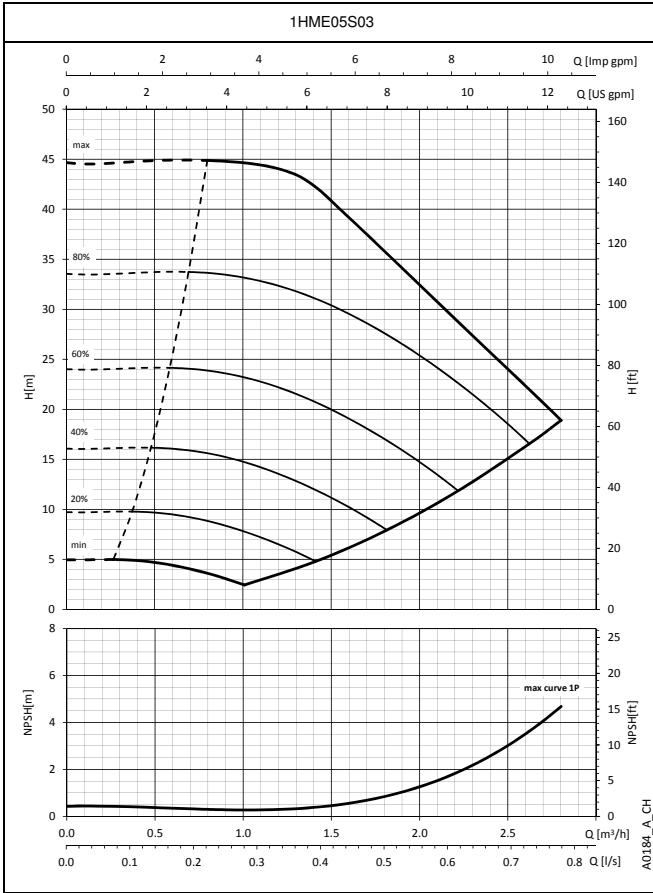

The performance curves do not take into account flow resistance in the valves and piping. The curves show the performance with one, two and three pumps running. These performances are valid for liquids with density  $\rho = 1 \text{ Kg/dm}^3$  and kinematic viscosity  $\nu = 1 \text{ mm}^2/\text{sec}$ . The declared NPSH values are laboratory values; for practical use we recommend increasing these values by 0,5 m.

## SMB.../HME BOOSTER SETS SERIES OPERATING CHARACTERISTICS

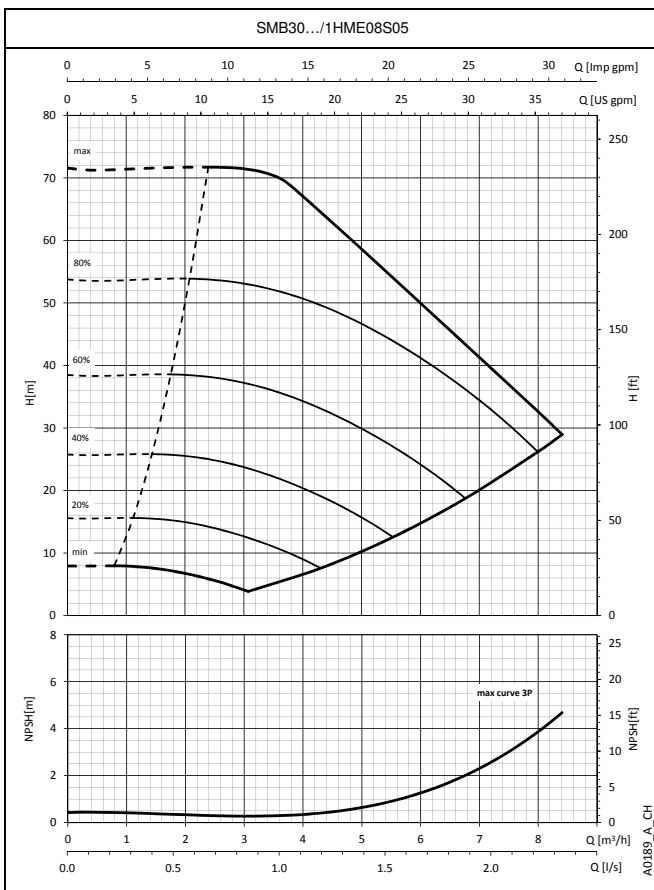
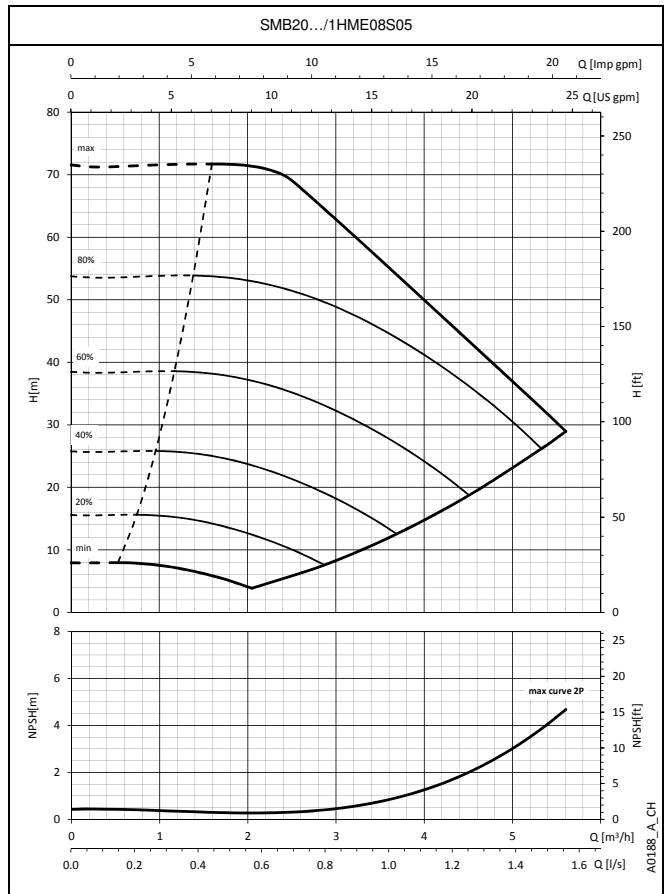
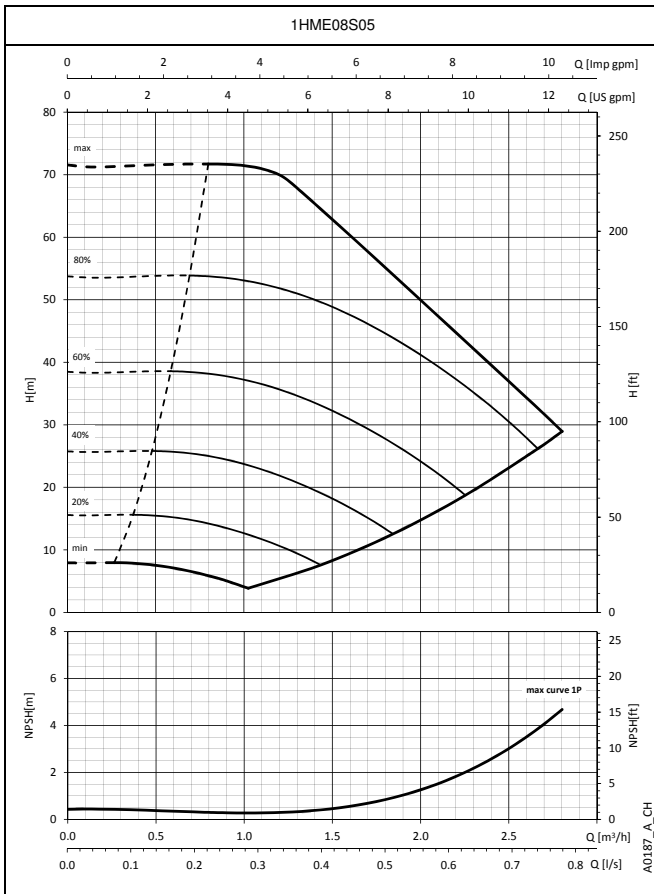

The performance curves do not take into account flow resistance in the valves and piping. The curves show the performance with one, two and three pumps running. These performances are valid for liquids with density  $\rho = 1 \text{ Kg/dm}^3$  and kinematic viscosity  $\nu = 1 \text{ mm}^2/\text{sec}$ . The declared NPSH values are laboratory values; for practical use we recommend increasing these values by 0,5 m.

## SMB.../HME BOOSTER SETS SERIES OPERATING CHARACTERISTICS

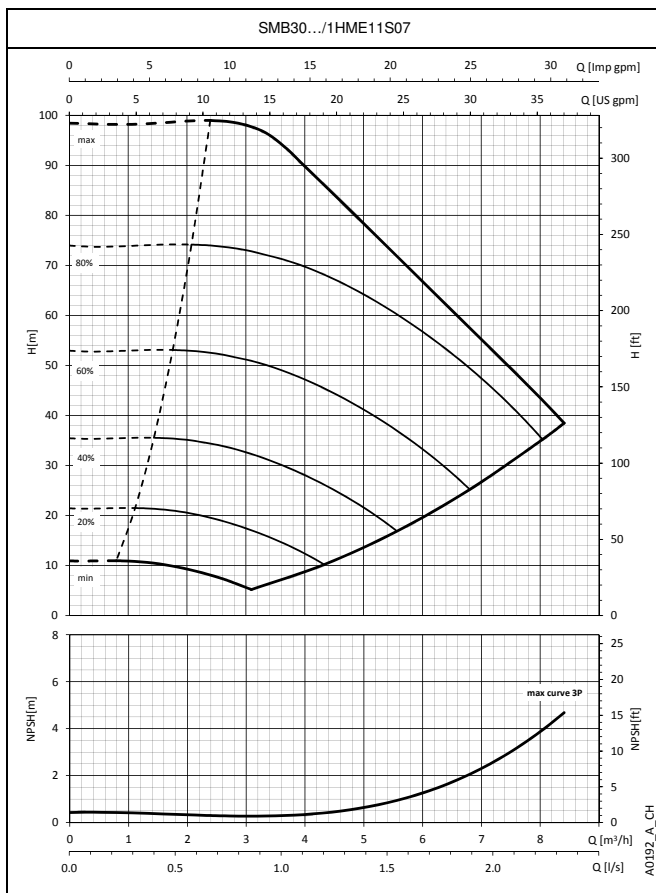
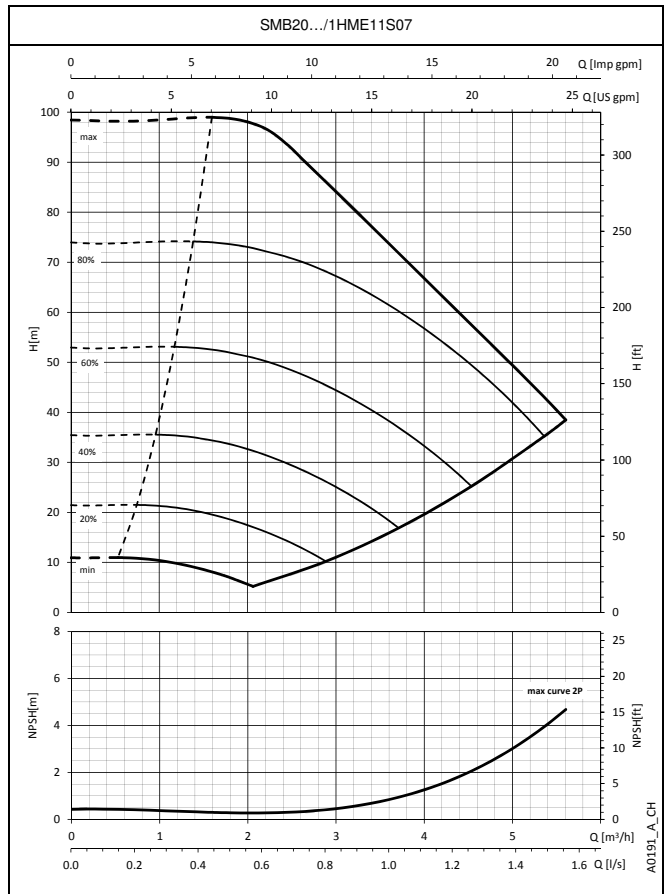
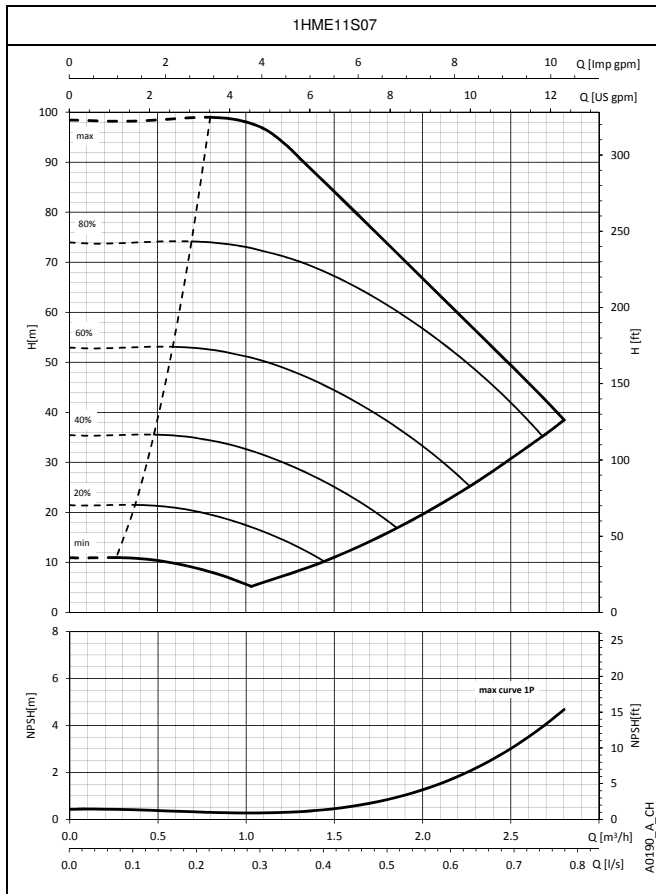

The performance curves do not take into account flow resistance in the valves and piping. The curves show the performance with one, two and three pumps running. These performances are valid for liquids with density  $\rho = 1 \text{ Kg/dm}^3$  and kinematic viscosity  $\nu = 1 \text{ mm}^2/\text{sec}$ . The declared NPSH values are laboratory values; for practical use we recommend increasing these values by 0,5 m.

## SMB.../HME BOOSTER SETS SERIES OPERATING CHARACTERISTICS

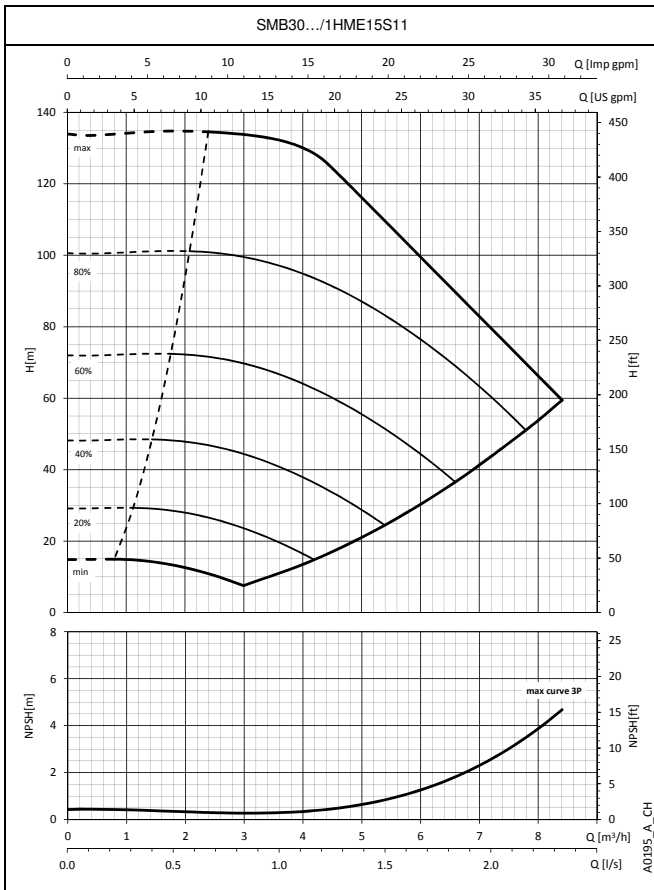
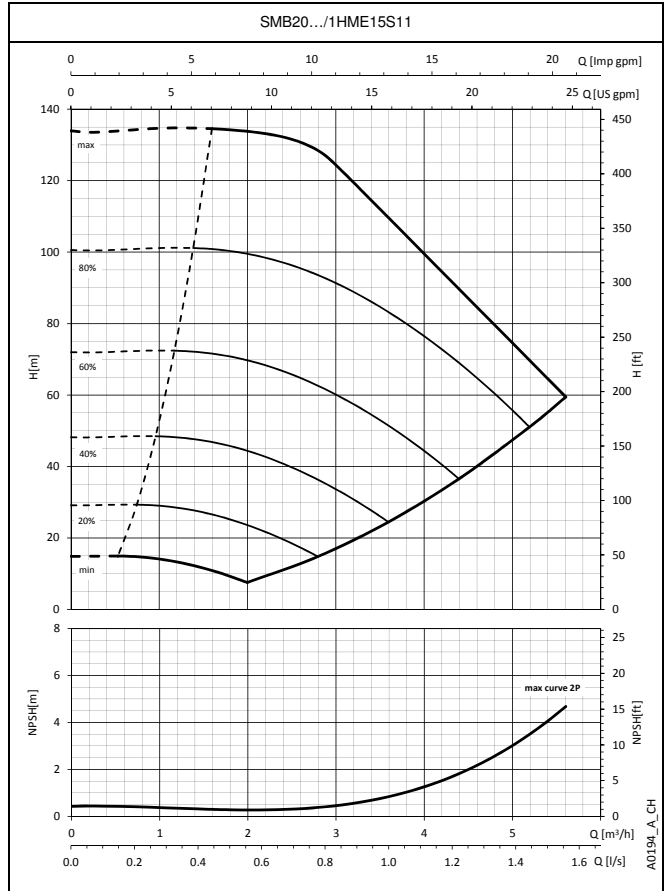
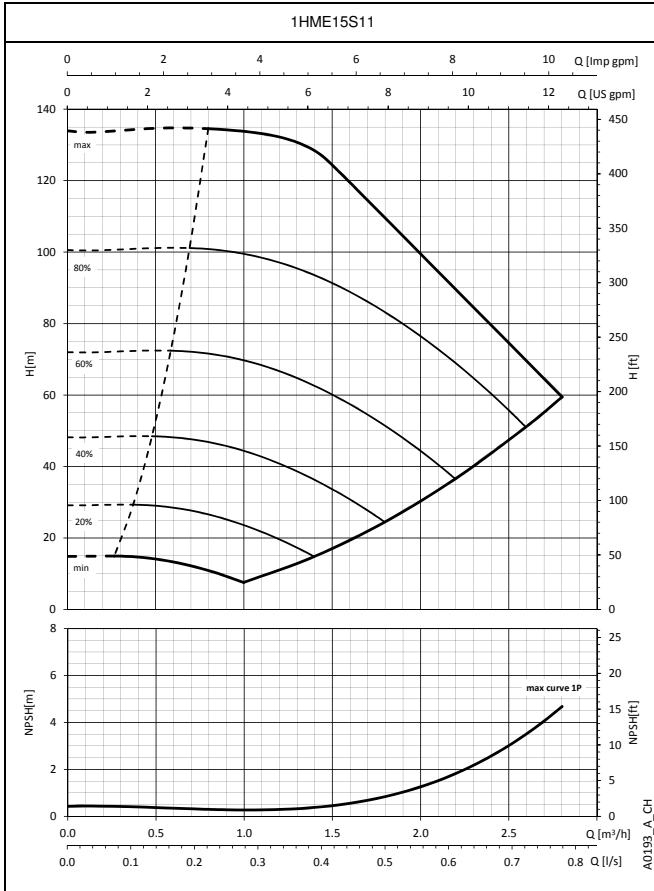

The performance curves do not take into account flow resistance in the valves and piping. The curves show the performance with one, two and three pumps running. These performances are valid for liquids with density  $\rho = 1 \text{ Kg/dm}^3$  and kinematic viscosity  $\nu = 1 \text{ mm}^2/\text{sec}$ . The declared NPSH values are laboratory values; for practical use we recommend increasing these values by 0,5 m.

## SMB.../HME BOOSTER SETS SERIES OPERATING CHARACTERISTICS

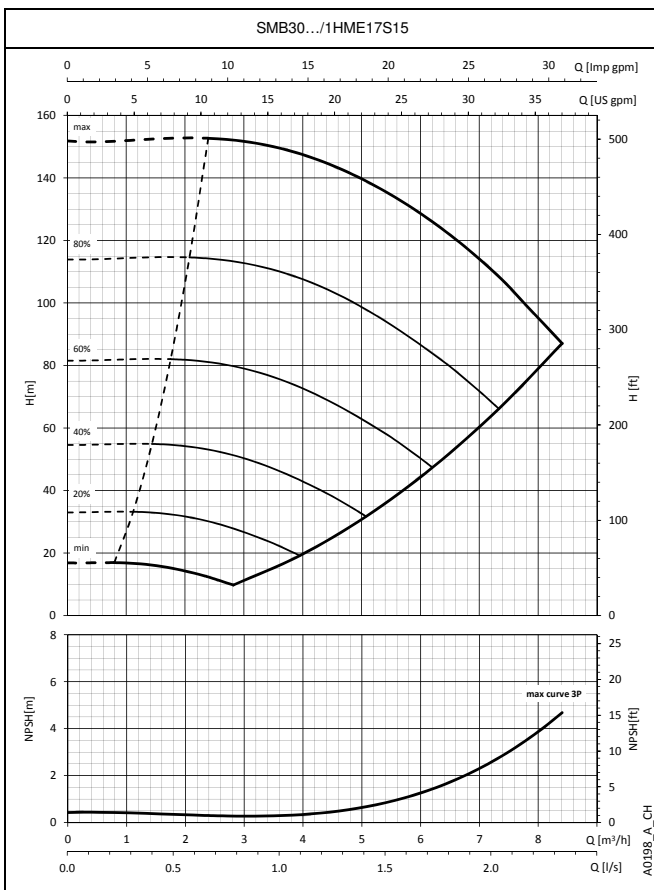
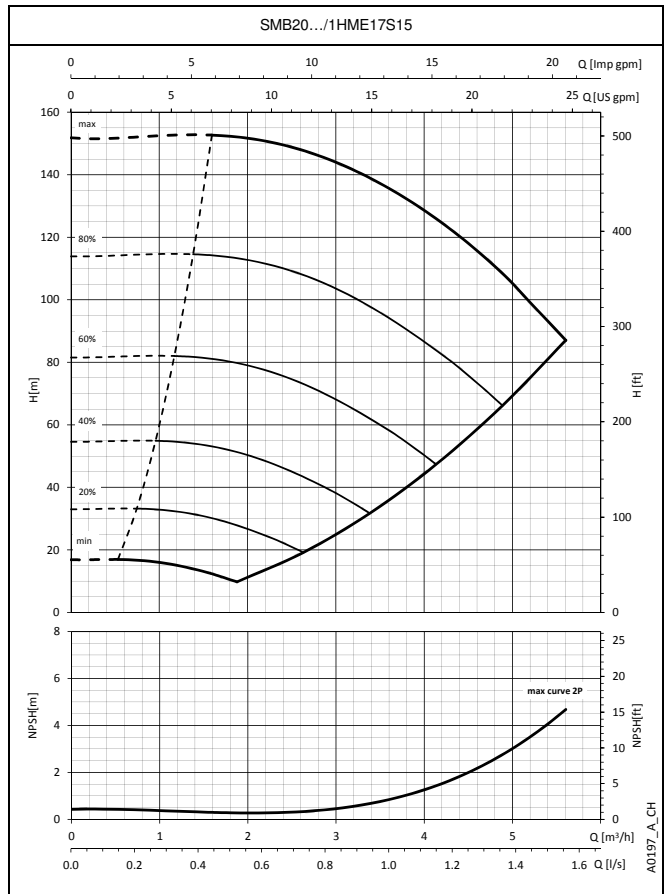
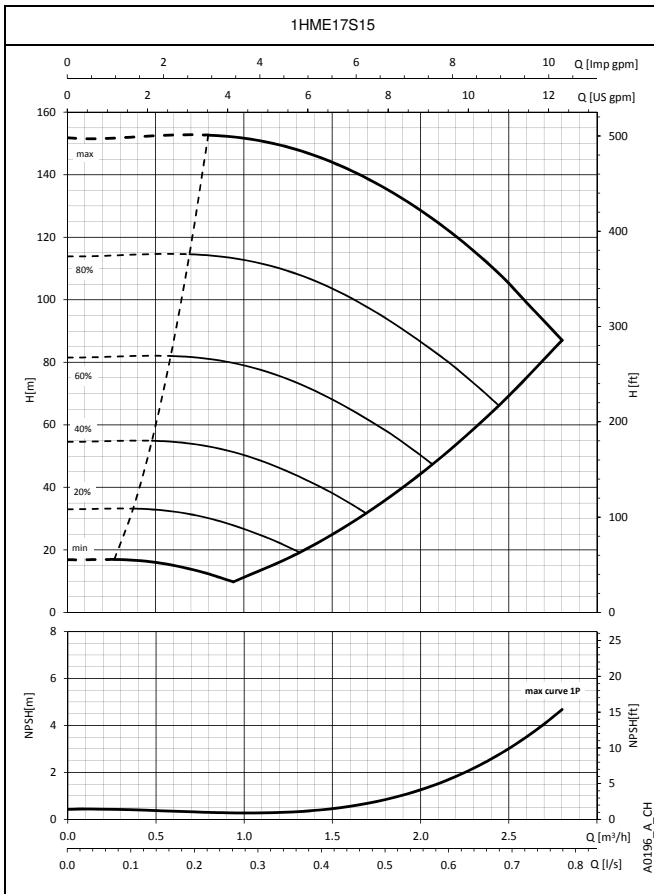

The performance curves do not take into account flow resistance in the valves and piping. The curves show the performance with one, two and three pumps running. These performances are valid for liquids with density  $\rho = 1 \text{ Kg/dm}^3$  and kinematic viscosity  $\nu = 1 \text{ mm}^2/\text{sec}$ . The declared NPSH values are laboratory values; for practical use we recommend increasing these values by 0,5 m.

## SMB.../HME BOOSTER SETS SERIES OPERATING CHARACTERISTICS

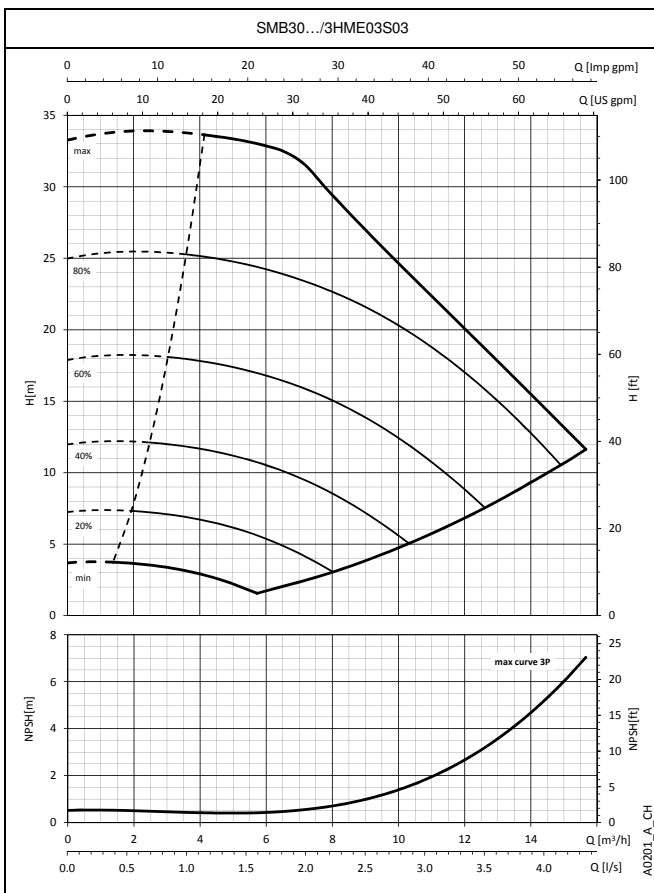
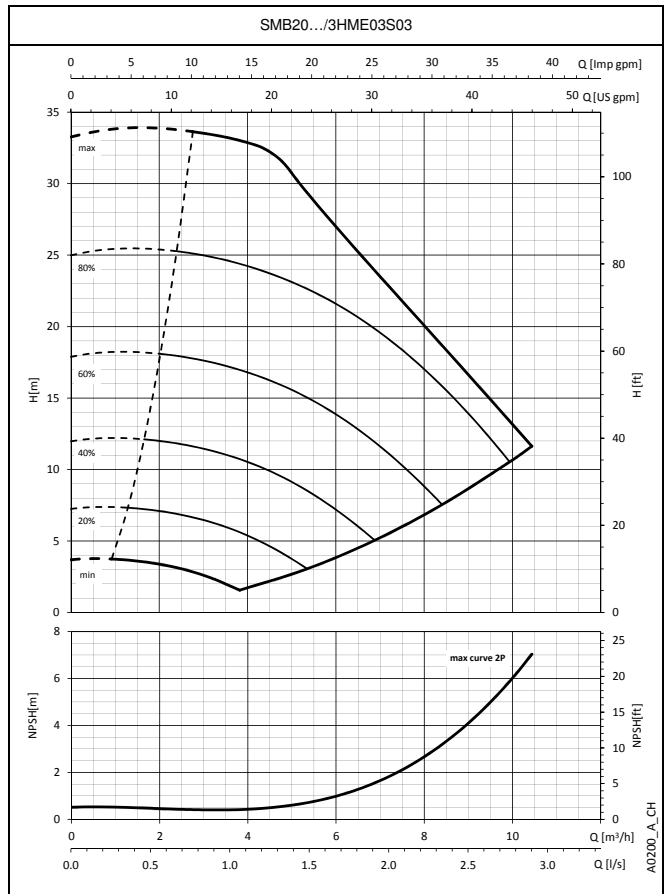
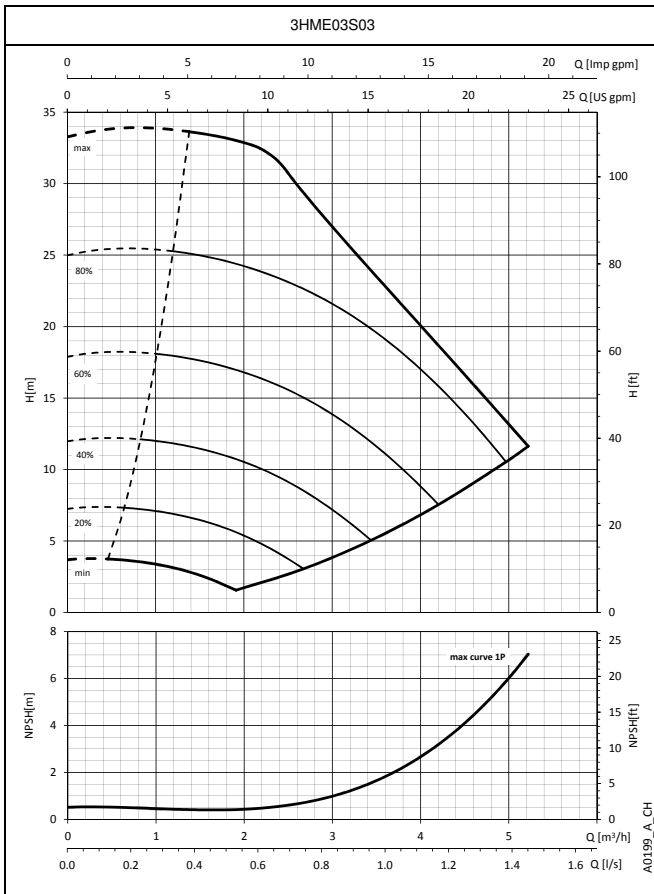

The performance curves do not take into account flow resistance in the valves and piping. The curves show the performance with one, two and three pumps running. These performances are valid for liquids with density  $\rho = 1 \text{ Kg/dm}^3$  and kinematic viscosity  $\nu = 1 \text{ mm}^2/\text{sec}$ . The declared NPSH values are laboratory values; for practical use we recommend increasing these values by 0,5 m.

**SMB.../HME BOOSTER SETS SERIES  
OPERATING CHARACTERISTICS**

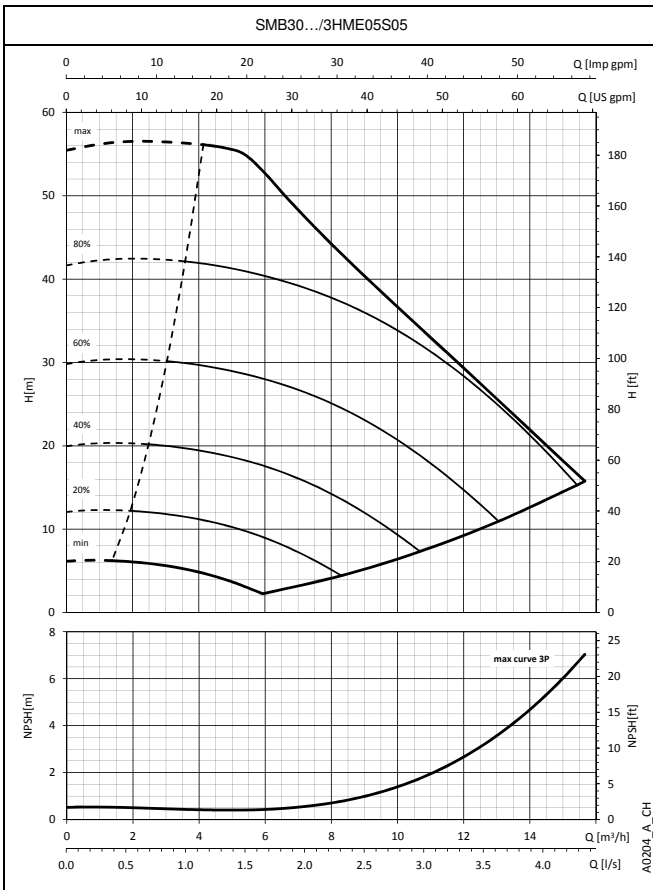
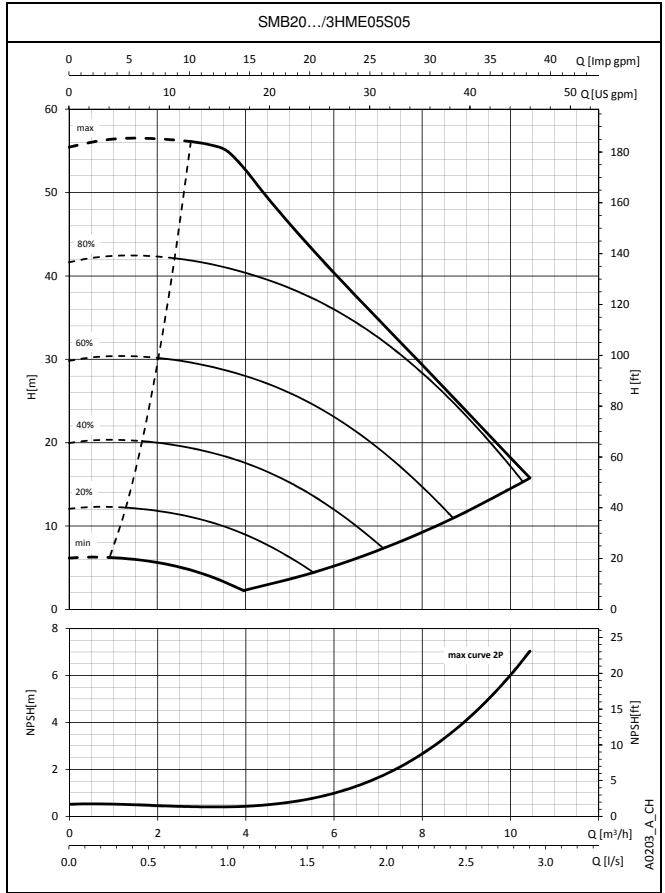
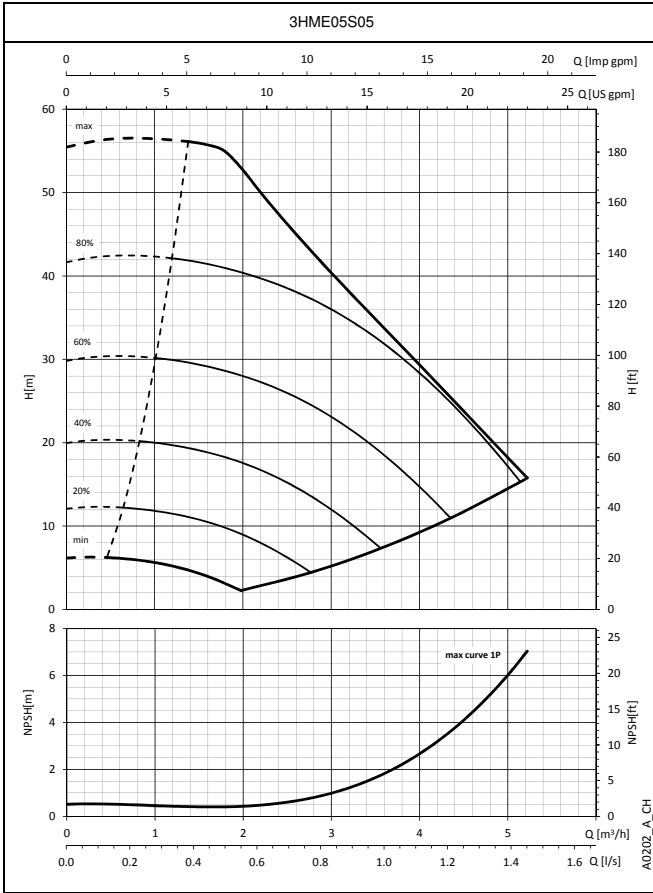

The performance curves do not take into account flow resistance in the valves and piping. The curves show the performance with one, two and three pumps running. These performances are valid for liquids with density  $\rho = 1 \text{ Kg/dm}^3$  and kinematic viscosity  $\nu = 1 \text{ mm}^2/\text{sec}$ . The declared NPSH values are laboratory values; for practical use we recommend increasing these values by 0,5 m.

**SMB.../HME BOOSTER SETS SERIES  
OPERATING CHARACTERISTICS**

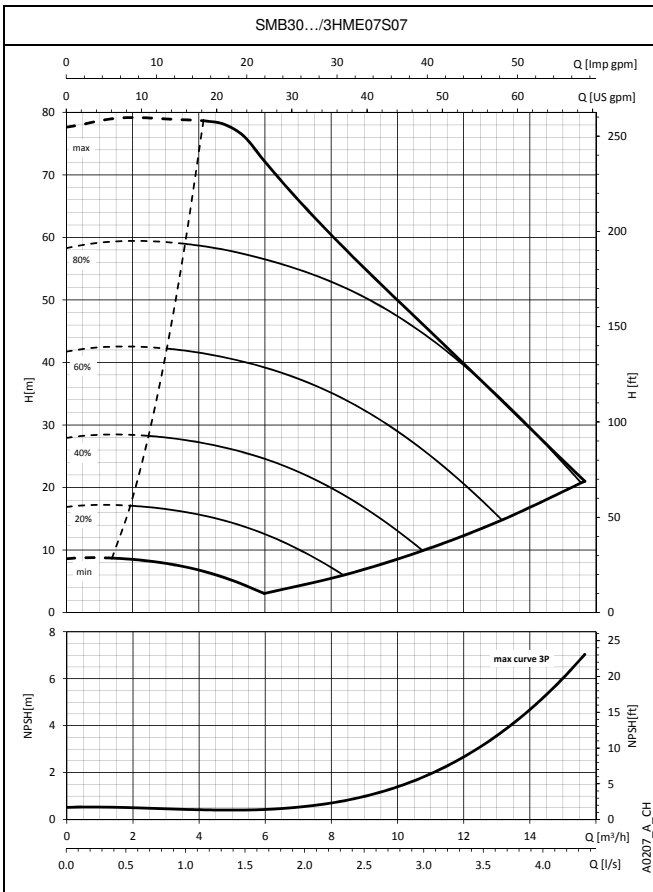
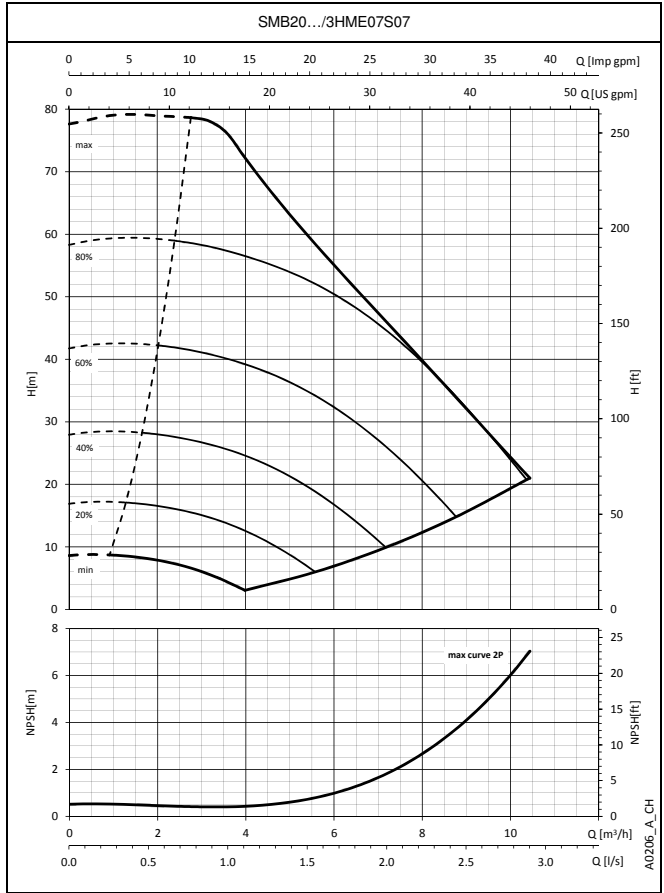
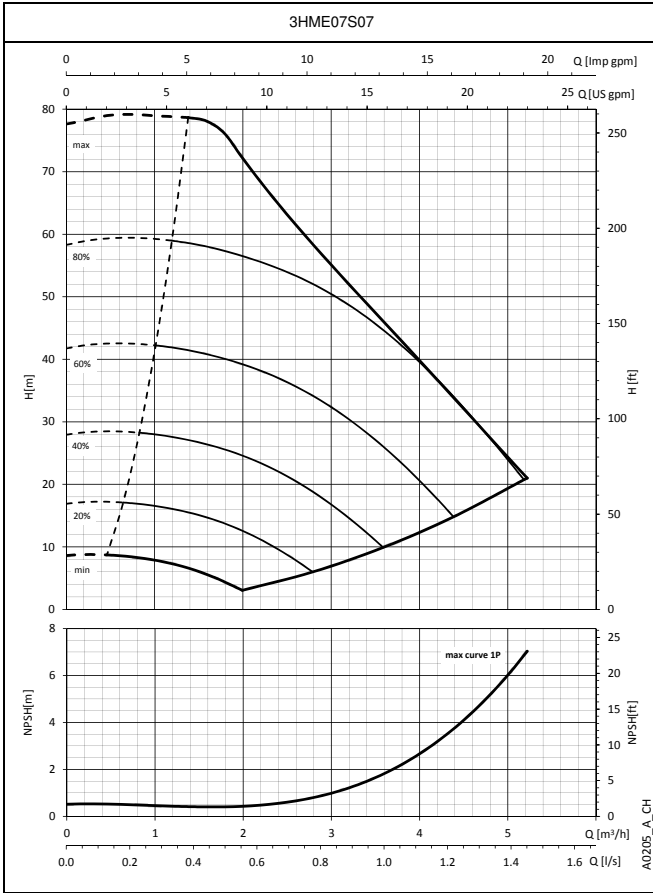

The performance curves do not take into account flow resistance in the valves and piping. The curves show the performance with one, two and three pumps running. These performances are valid for liquids with density  $\rho = 1 \text{ Kg/dm}^3$  and kinematic viscosity  $\nu = 1 \text{ mm}^2/\text{sec}$ . The declared NPSH values are laboratory values; for practical use we recommend increasing these values by 0,5 m.

## SMB.../HME BOOSTER SETS SERIES OPERATING CHARACTERISTICS

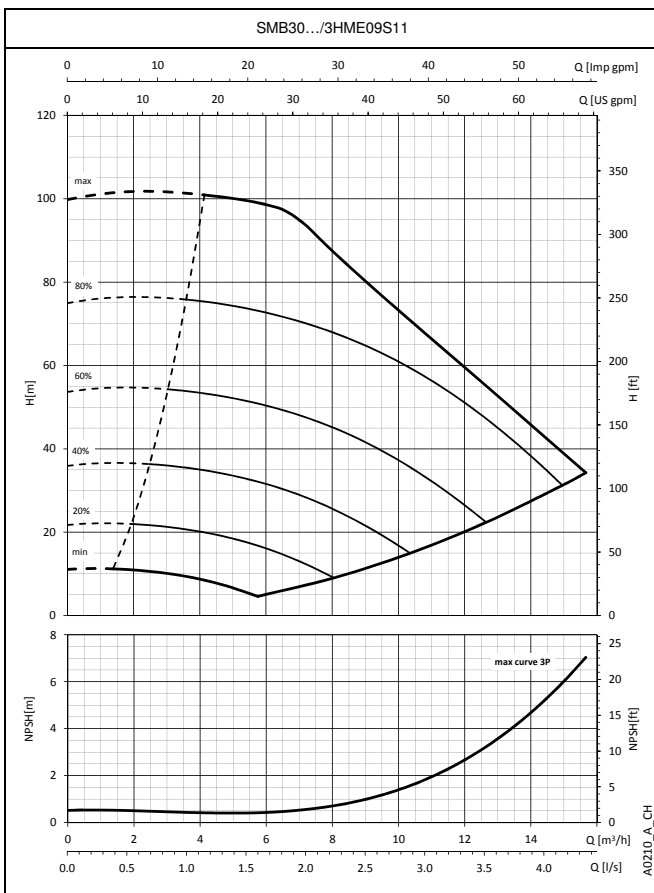
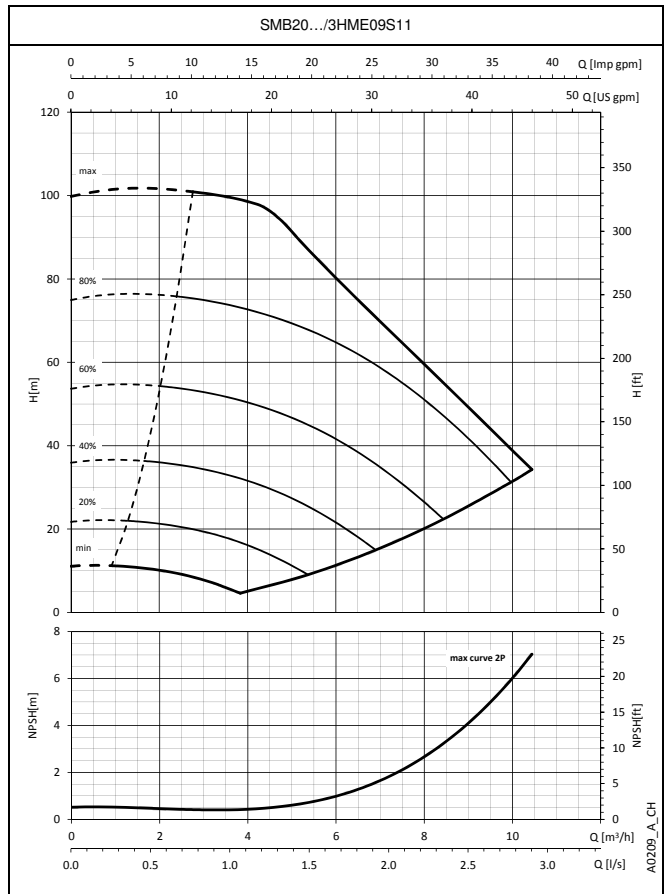
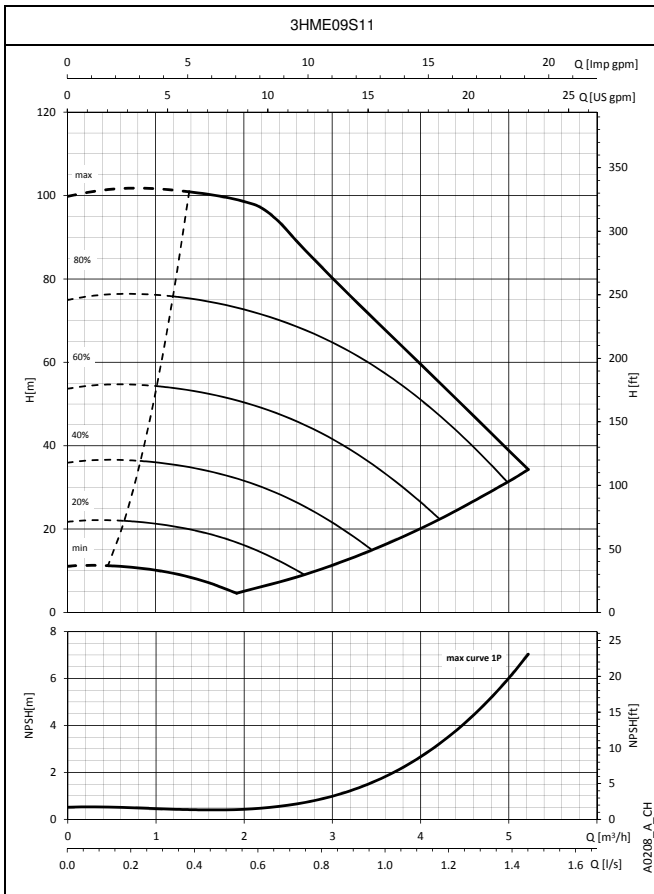

The performance curves do not take into account flow resistance in the valves and piping. The curves show the performance with one, two and three pumps running. These performances are valid for liquids with density  $\rho = 1 \text{ Kg/dm}^3$  and kinematic viscosity  $\nu = 1 \text{ mm}^2/\text{sec}$ . The declared NPSH values are laboratory values; for practical use we recommend increasing these values by 0,5 m.

**SMB.../HME BOOSTER SETS SERIES  
OPERATING CHARACTERISTICS**

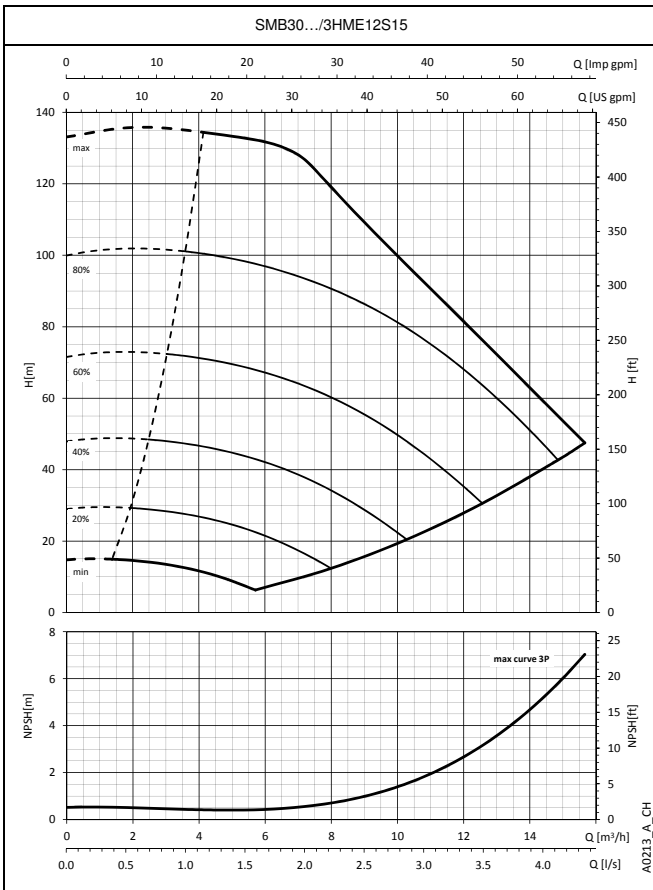
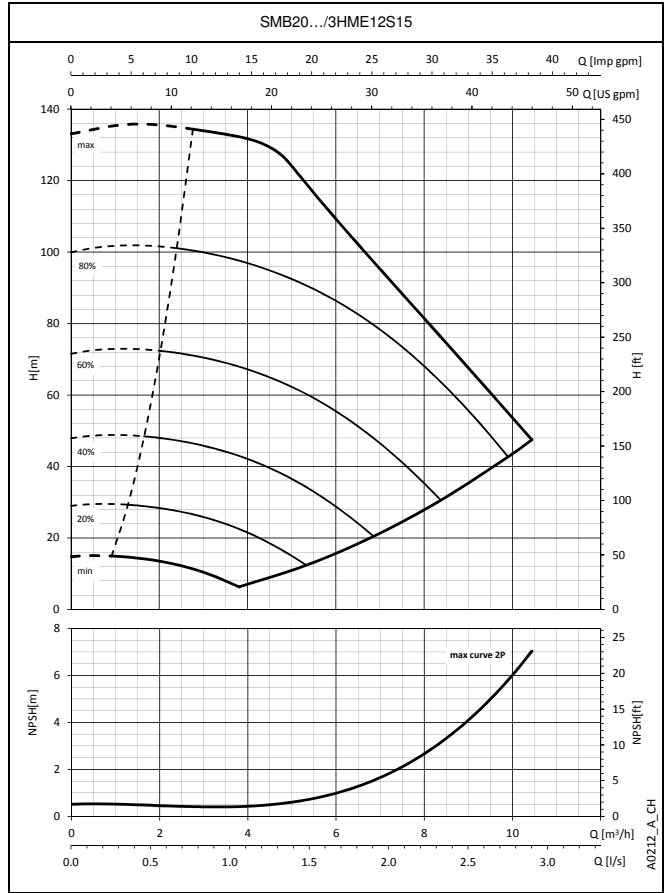
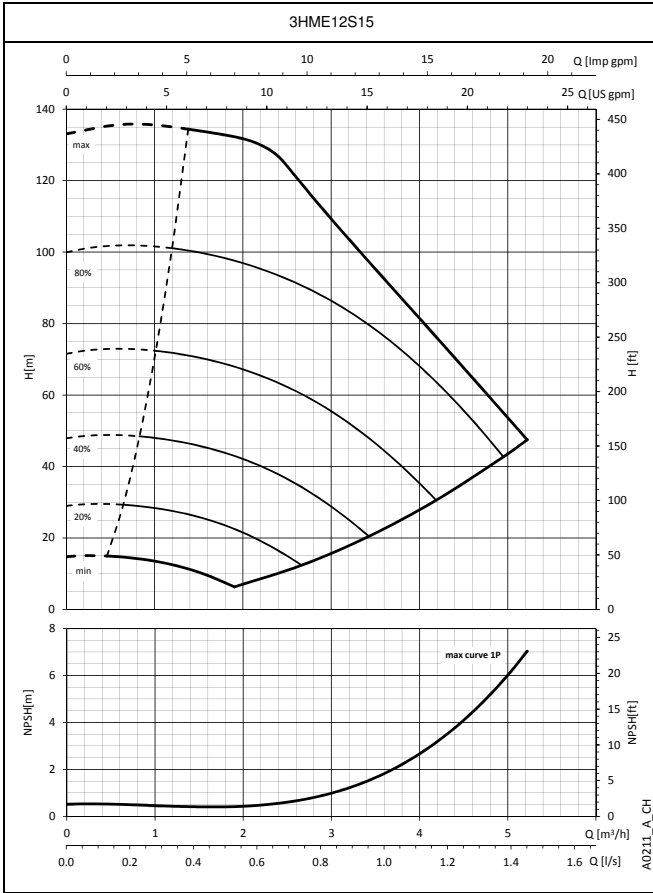

The performance curves do not take into account flow resistance in the valves and piping. The curves show the performance with one, two and three pumps running. These performances are valid for liquids with density  $\rho = 1 \text{ Kg/dm}^3$  and kinematic viscosity  $\nu = 1 \text{ mm}^2/\text{sec}$ . The declared NPSH values are laboratory values; for practical use we recommend increasing these values by 0,5 m.

## SMB.../HME BOOSTER SETS SERIES OPERATING CHARACTERISTICS

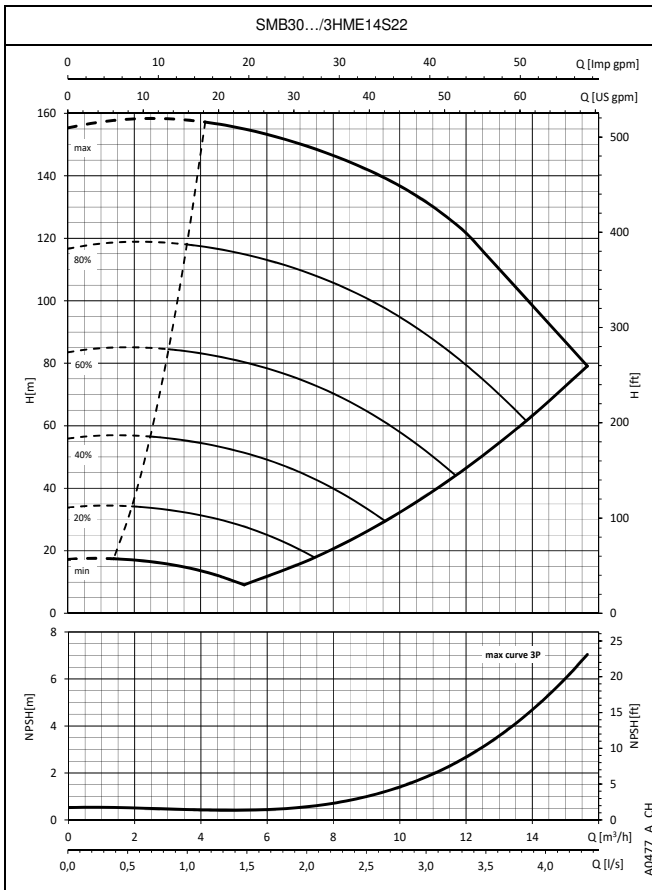
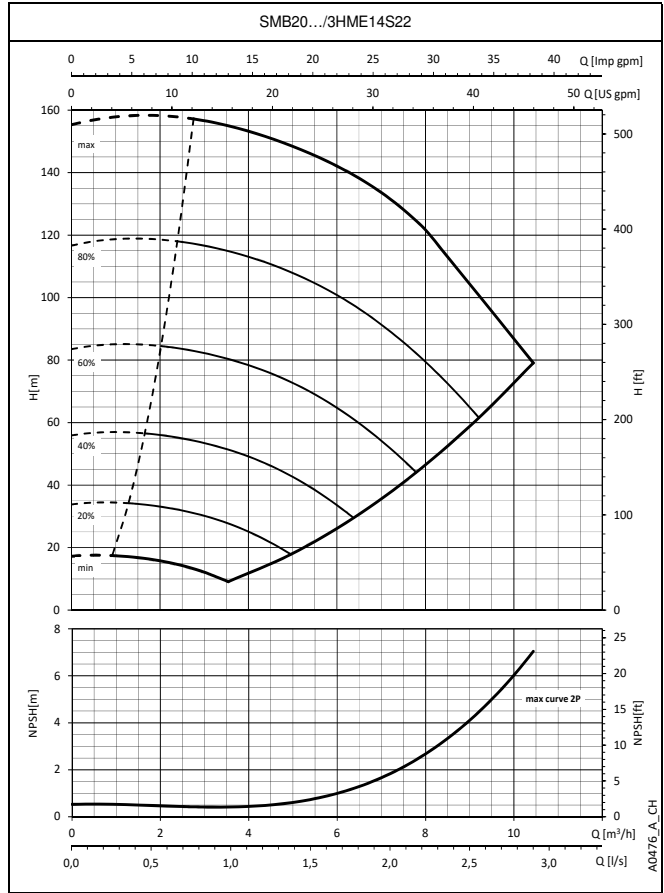
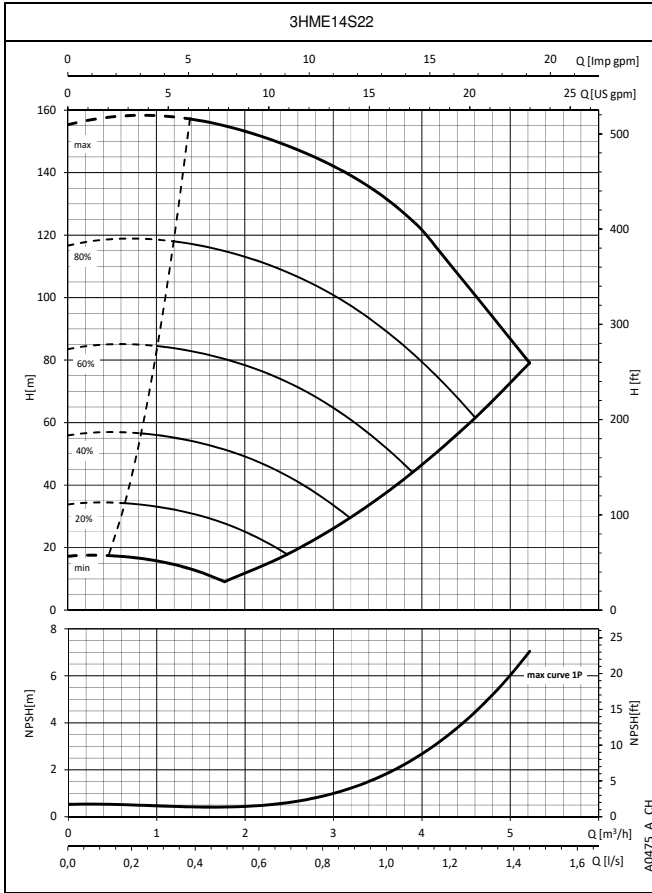

The performance curves do not take into account flow resistance in the valves and piping. The curves show the performance with one, two and three pumps running. These performances are valid for liquids with density  $\rho = 1 \text{ Kg/dm}^3$  and kinematic viscosity  $\nu = 1 \text{ mm}^2/\text{sec}$ . The declared NPSH values are laboratory values; for practical use we recommend increasing these values by 0,5 m.

**SMB.../HME BOOSTER SETS SERIES  
OPERATING CHARACTERISTICS**

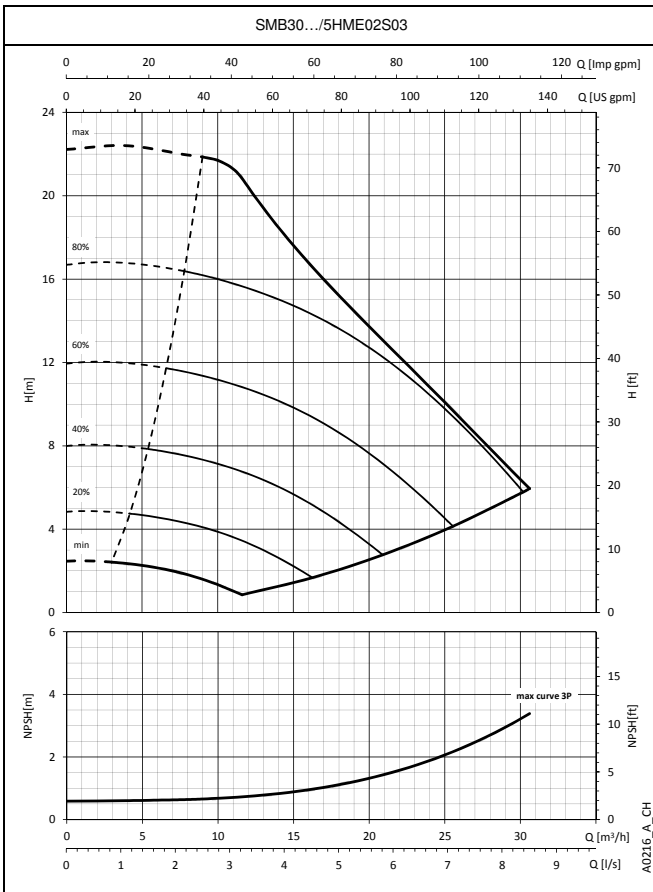
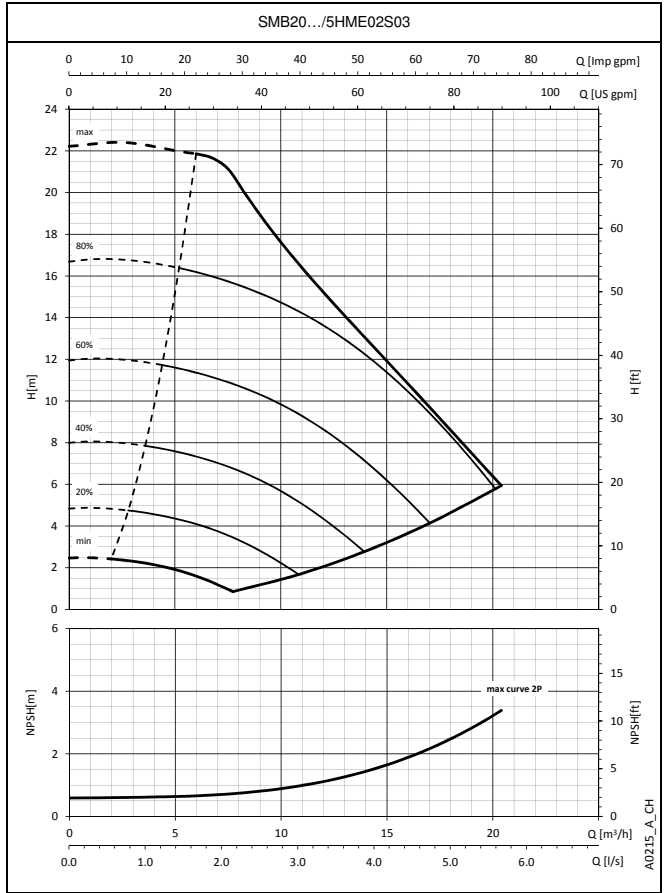
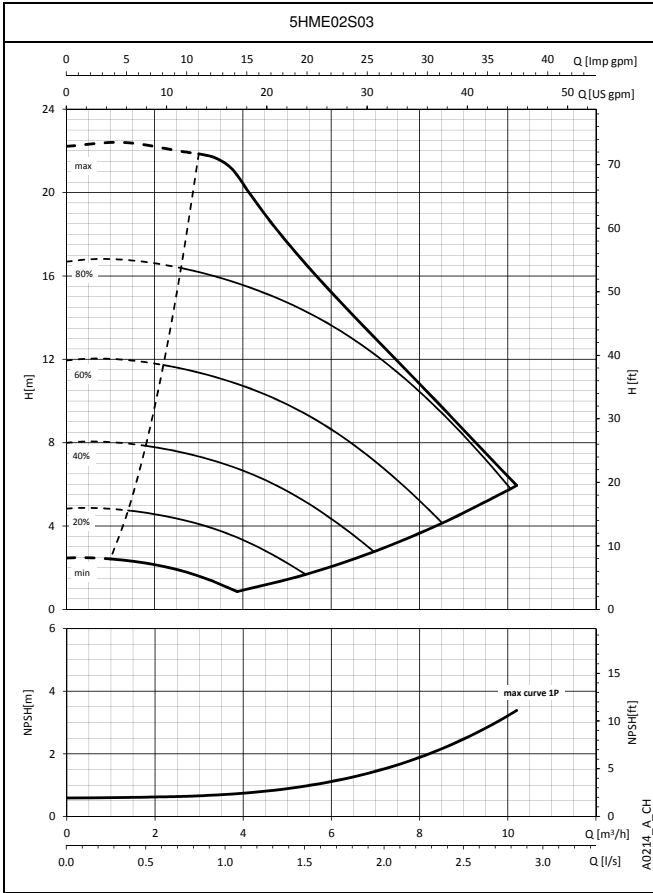

The performance curves do not take into account flow resistance in the valves and piping. The curves show the performance with one, two and three pumps running. These performances are valid for liquids with density  $\rho = 1 \text{ Kg/dm}^3$  and kinematic viscosity  $\nu = 1 \text{ mm}^2/\text{sec}$ . The declared NPSH values are laboratory values; for practical use we recommend increasing these values by 0,5 m.

## SMB.../HME BOOSTER SETS SERIES OPERATING CHARACTERISTICS

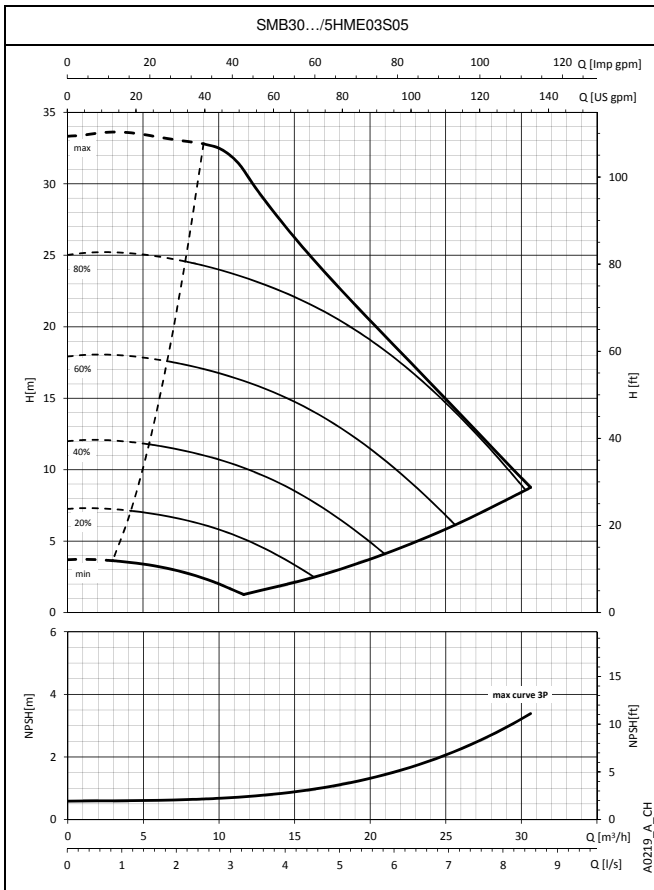
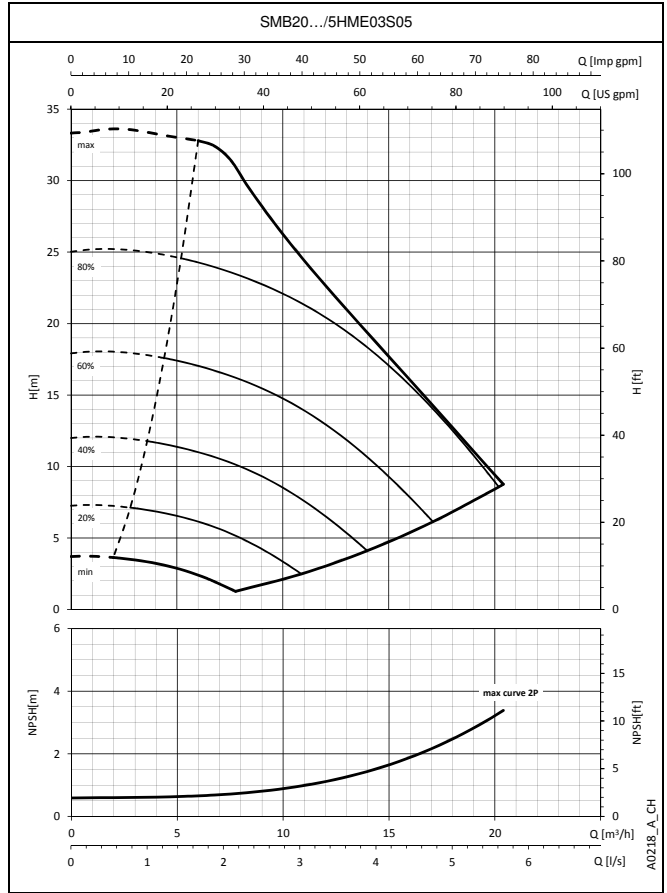
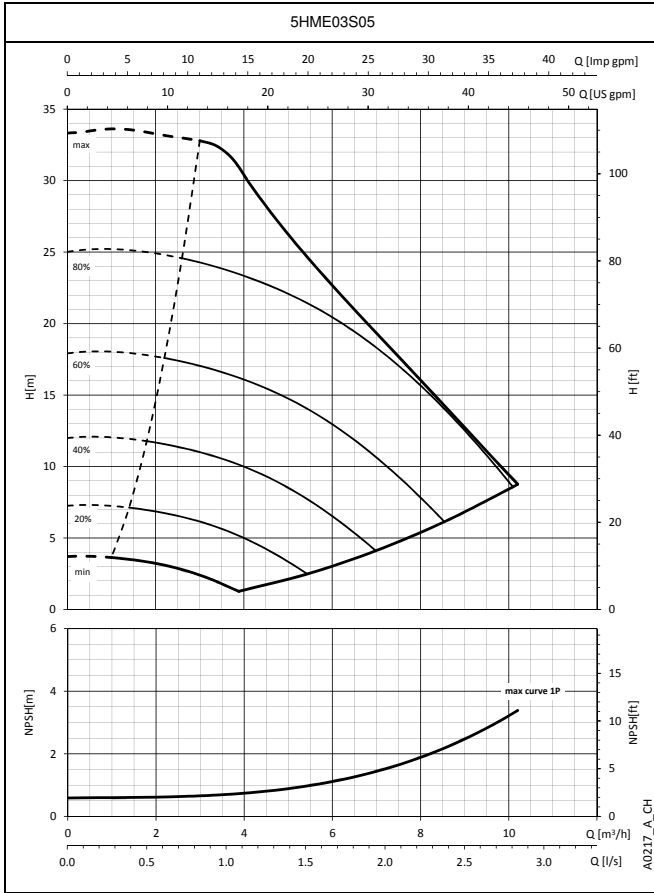

The performance curves do not take into account flow resistance in the valves and piping. The curves show the performance with one, two and three pumps running. These performances are valid for liquids with density  $\rho = 1 \text{ Kg/dm}^3$  and kinematic viscosity  $\nu = 1 \text{ mm}^2/\text{sec}$ . The declared NPSH values are laboratory values; for practical use we recommend increasing these values by 0,5 m.

## SMB.../HME BOOSTER SETS SERIES OPERATING CHARACTERISTICS

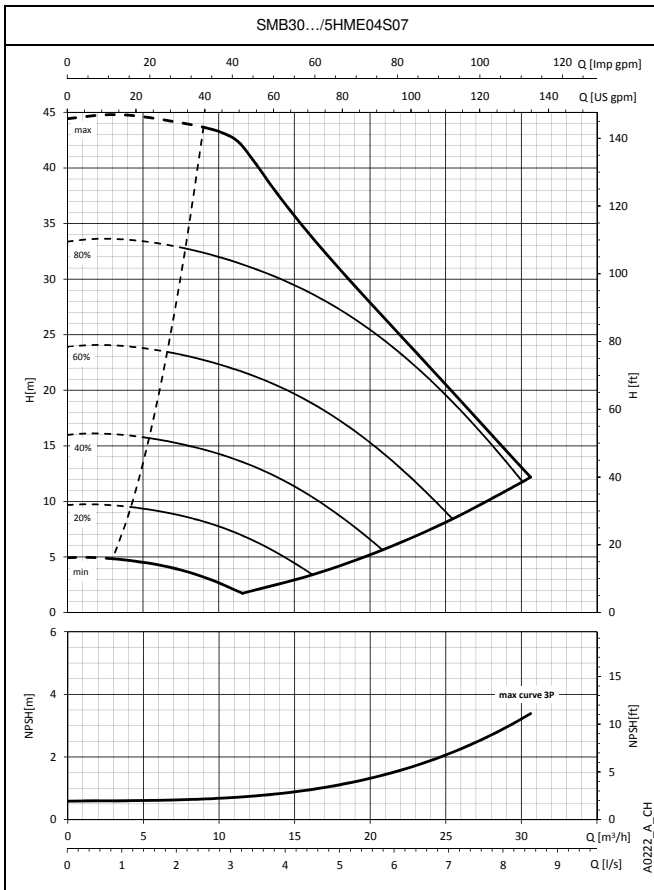
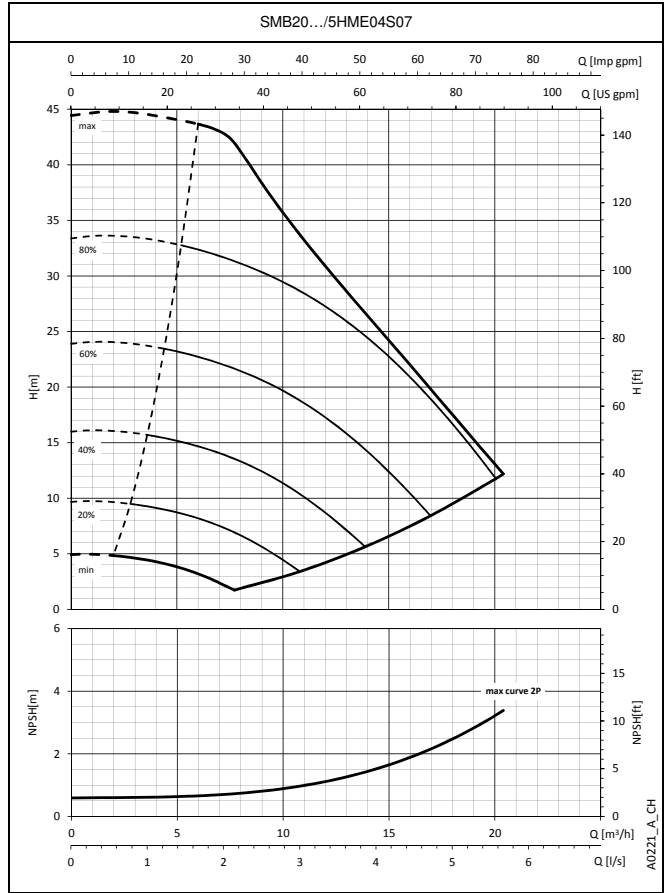
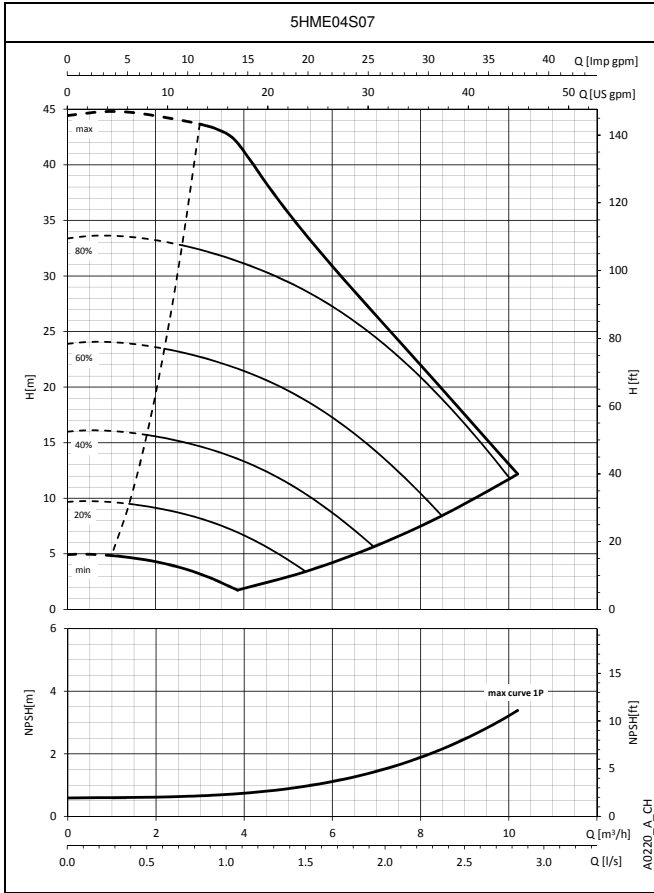

The performance curves do not take into account flow resistance in the valves and piping. The curves show the performance with one, two and three pumps running. These performances are valid for liquids with density  $\rho = 1 \text{ Kg/dm}^3$  and kinematic viscosity  $\nu = 1 \text{ mm}^2/\text{sec}$ . The declared NPSH values are laboratory values; for practical use we recommend increasing these values by 0,5 m.

## SMB.../HME BOOSTER SETS SERIES OPERATING CHARACTERISTICS

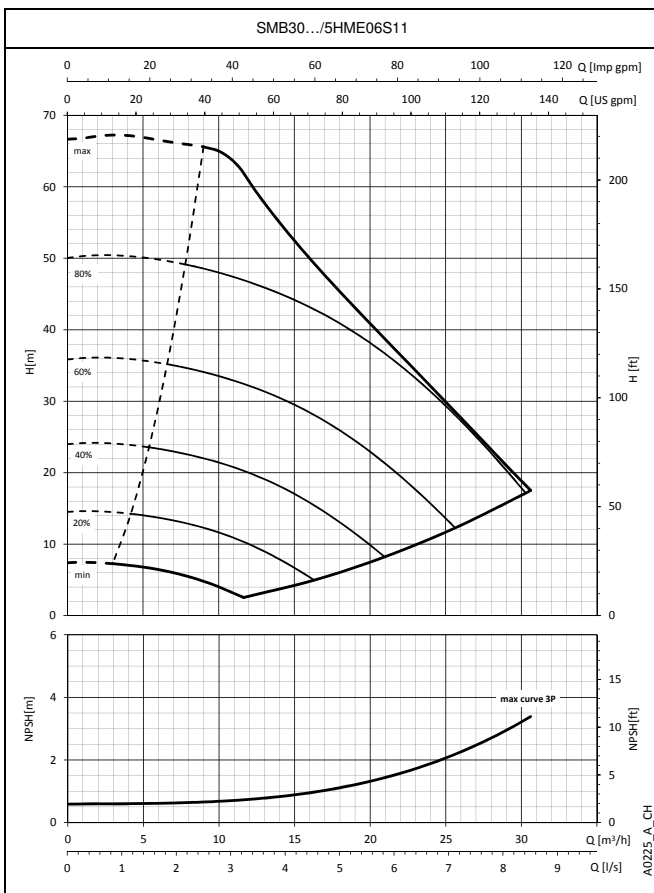
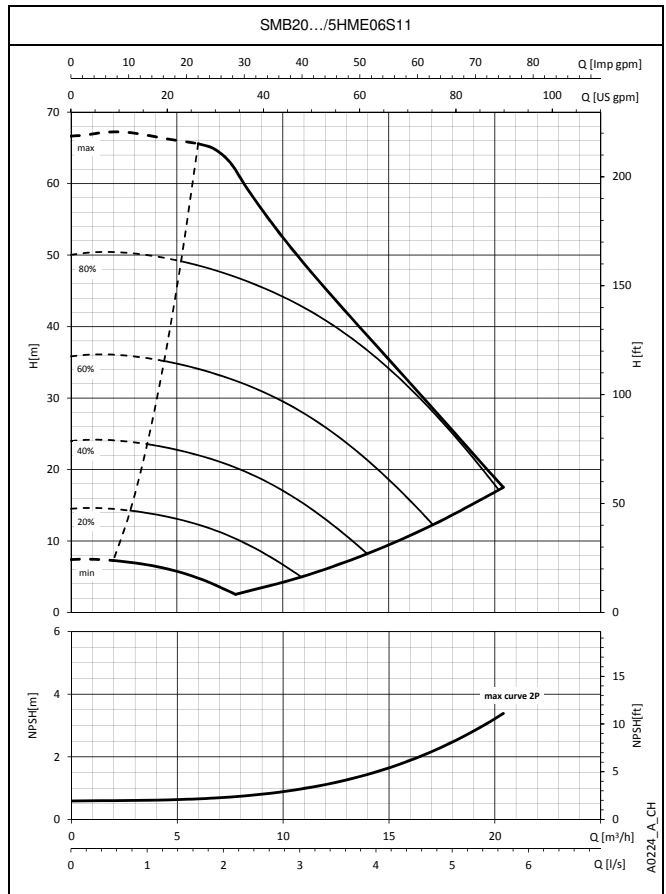
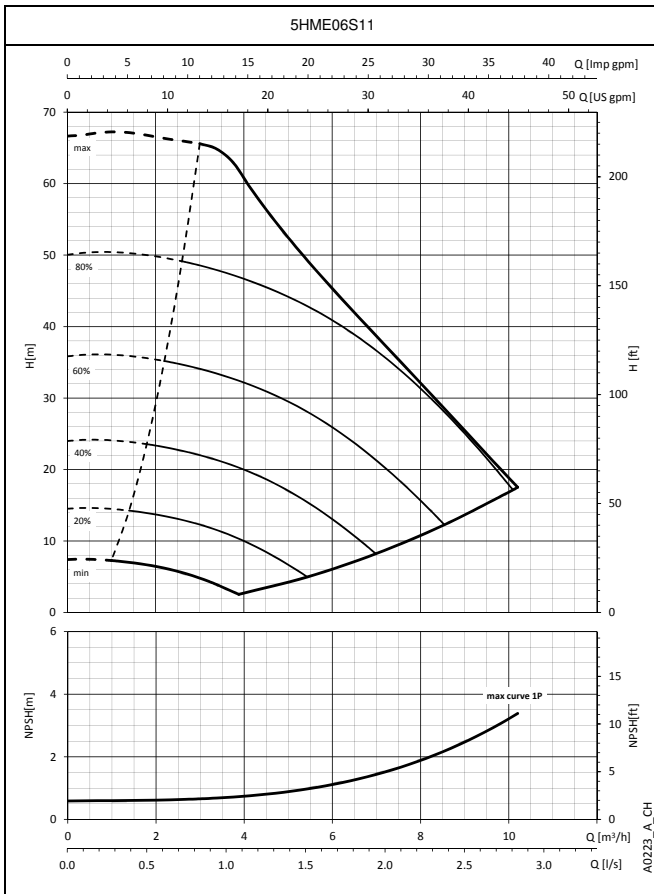

The performance curves do not take into account flow resistance in the valves and piping. The curves show the performance with one, two and three pumps running. These performances are valid for liquids with density  $\rho = 1 \text{ Kg/dm}^3$  and kinematic viscosity  $\nu = 1 \text{ mm}^2/\text{sec}$ . The declared NPSH values are laboratory values; for practical use we recommend increasing these values by 0,5 m.

## SMB.../HME BOOSTER SETS SERIES OPERATING CHARACTERISTICS

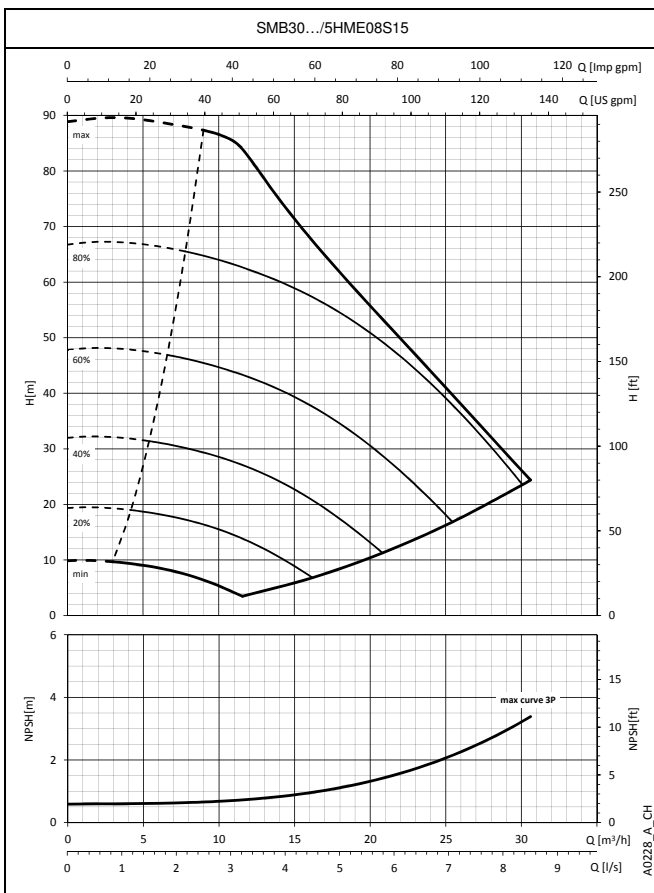
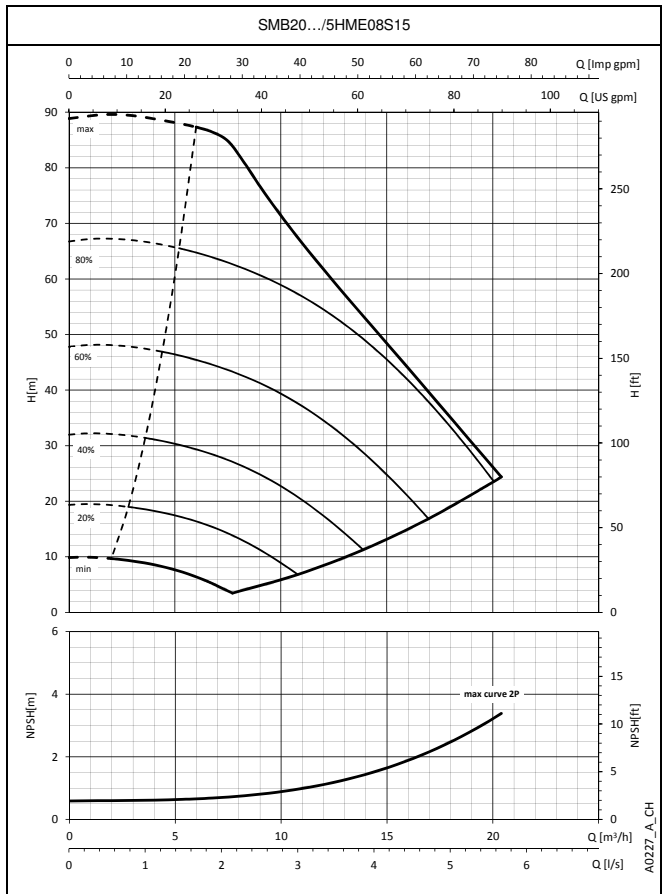
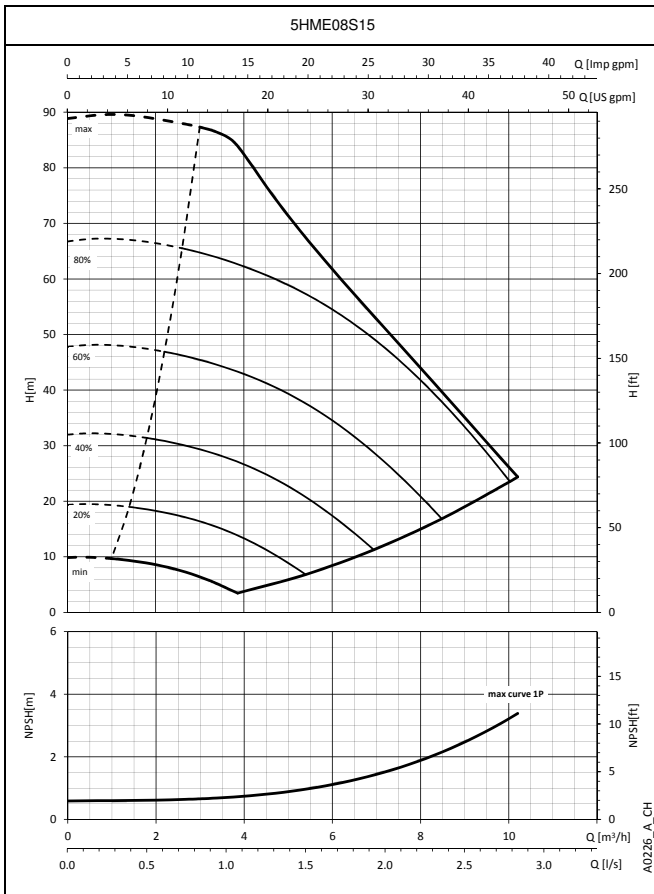

The performance curves do not take into account flow resistance in the valves and piping. The curves show the performance with one, two and three pumps running. These performances are valid for liquids with density  $\rho = 1 \text{ Kg/dm}^3$  and kinematic viscosity  $\nu = 1 \text{ mm}^2/\text{sec}$ . The declared NPSH values are laboratory values; for practical use we recommend increasing these values by 0,5 m.

## SMB.../HME BOOSTER SETS SERIES OPERATING CHARACTERISTICS

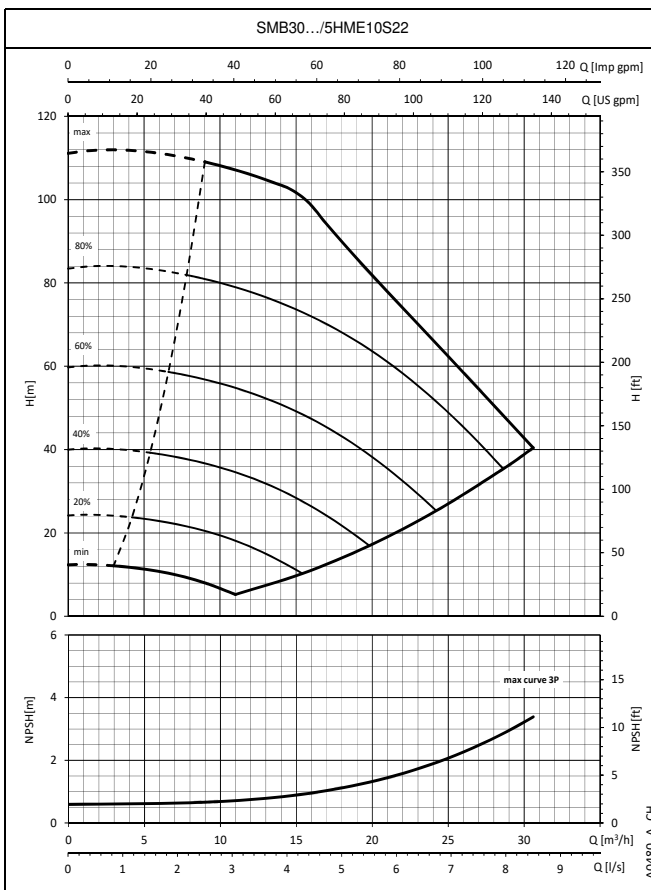
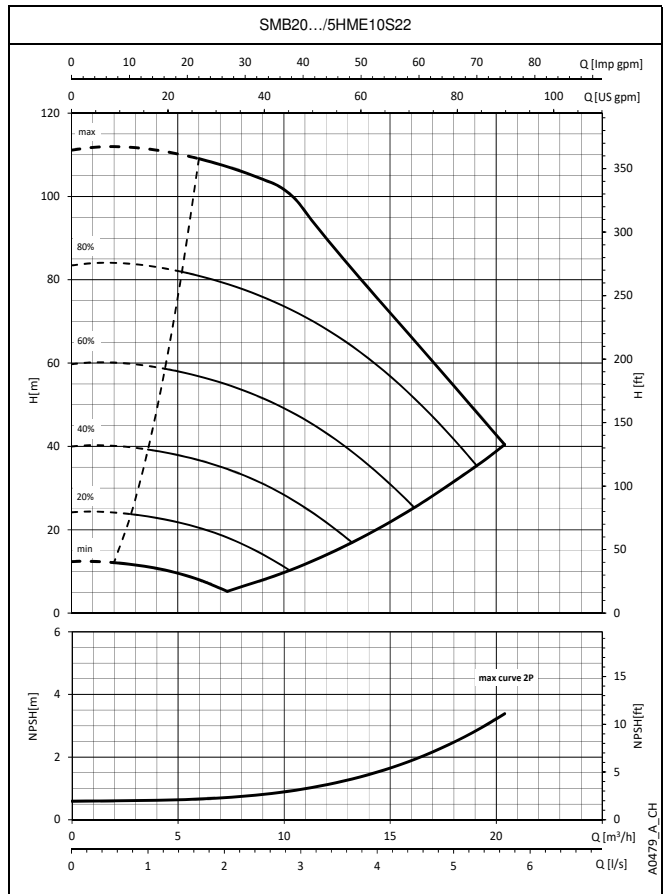
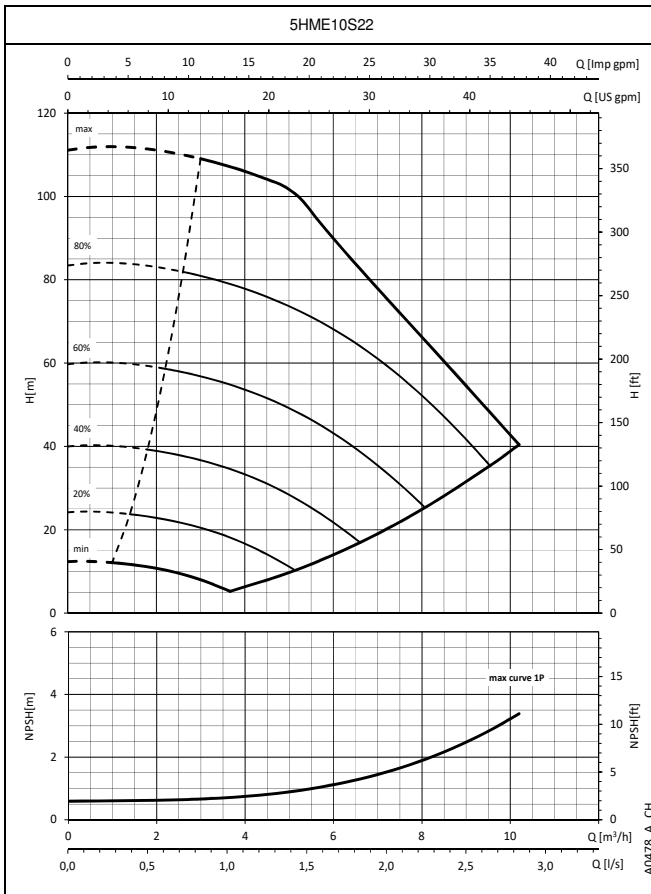

The performance curves do not take into account flow resistance in the valves and piping. The curves show the performance with one, two and three pumps running. These performances are valid for liquids with density  $\rho = 1 \text{ Kg/dm}^3$  and kinematic viscosity  $\nu = 1 \text{ mm}^2/\text{sec}$ . The declared NPSH values are laboratory values; for practical use we recommend increasing these values by 0,5 m.

## SMB.../HME BOOSTER SETS SERIES OPERATING CHARACTERISTICS

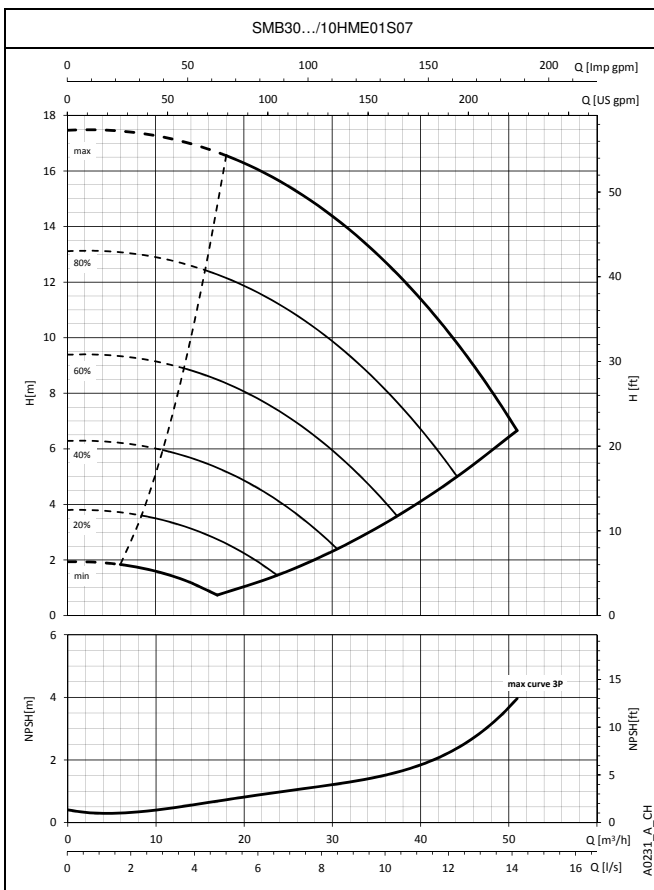
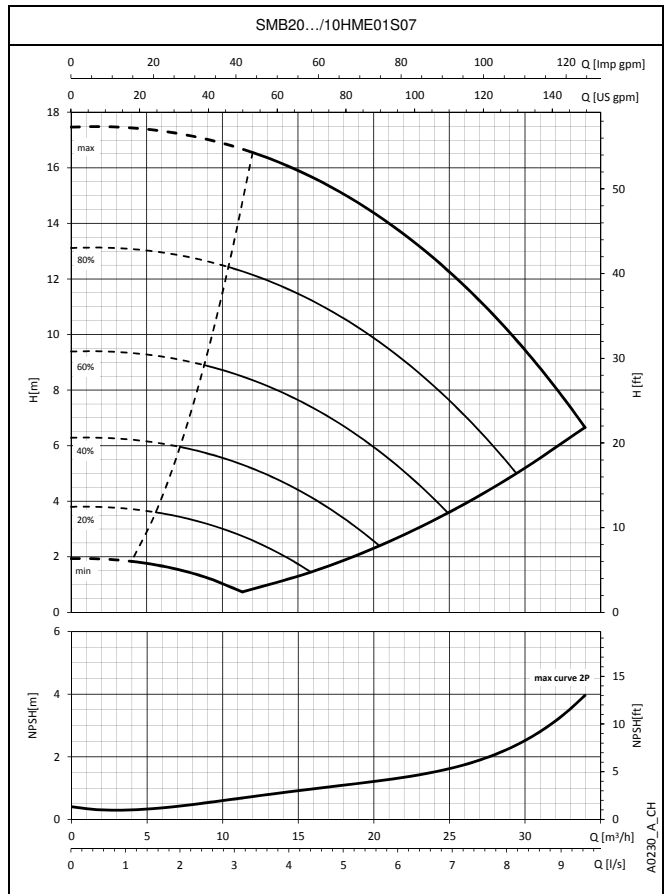
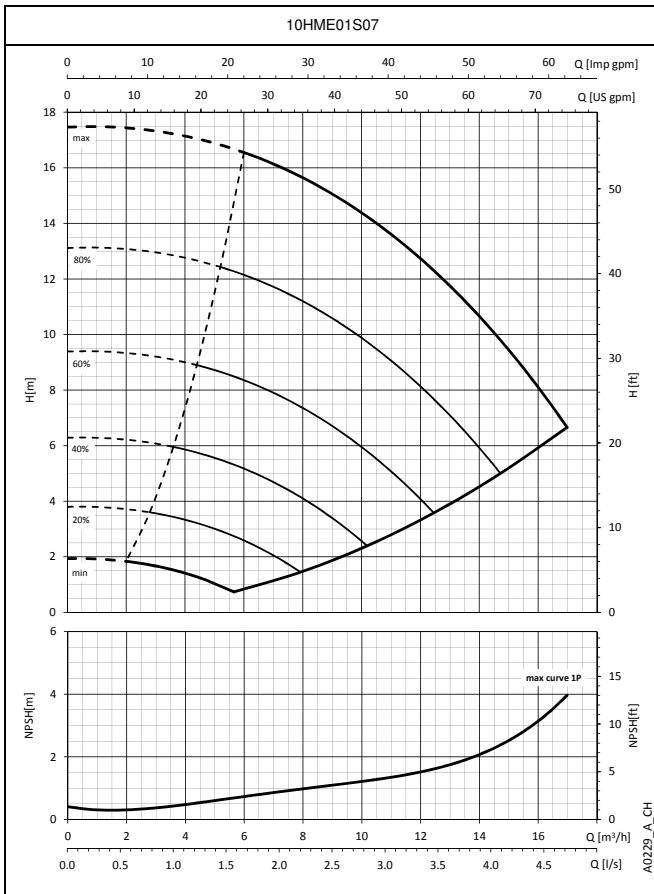

The performance curves do not take into account flow resistance in the valves and piping. The curves show the performance with one, two and three pumps running. These performances are valid for liquids with density  $\rho = 1 \text{ Kg/dm}^3$  and kinematic viscosity  $\nu = 1 \text{ mm}^2/\text{sec}$ . The declared NPSH values are laboratory values; for practical use we recommend increasing these values by 0,5 m.

## SMB.../HME BOOSTER SETS SERIES OPERATING CHARACTERISTICS

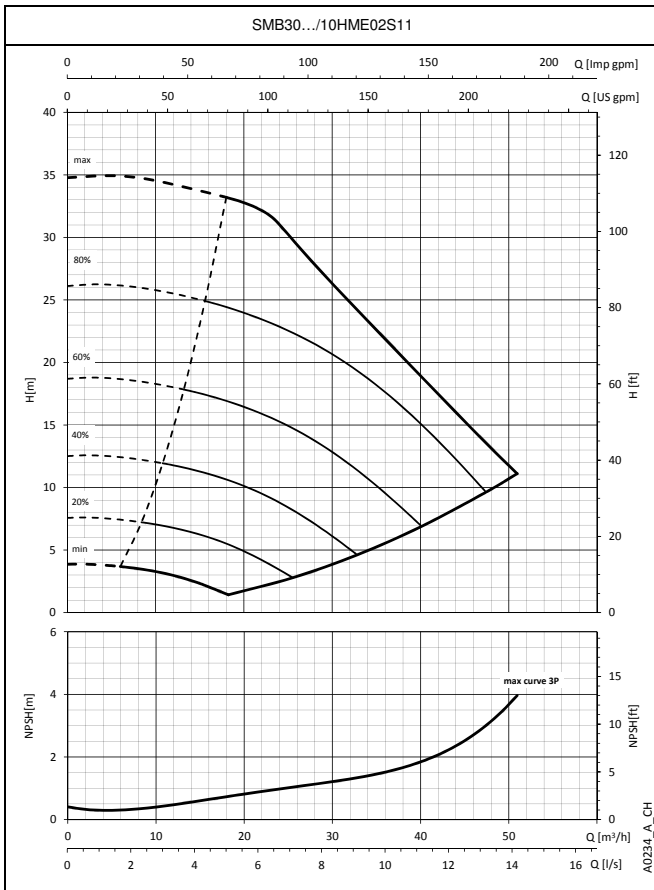
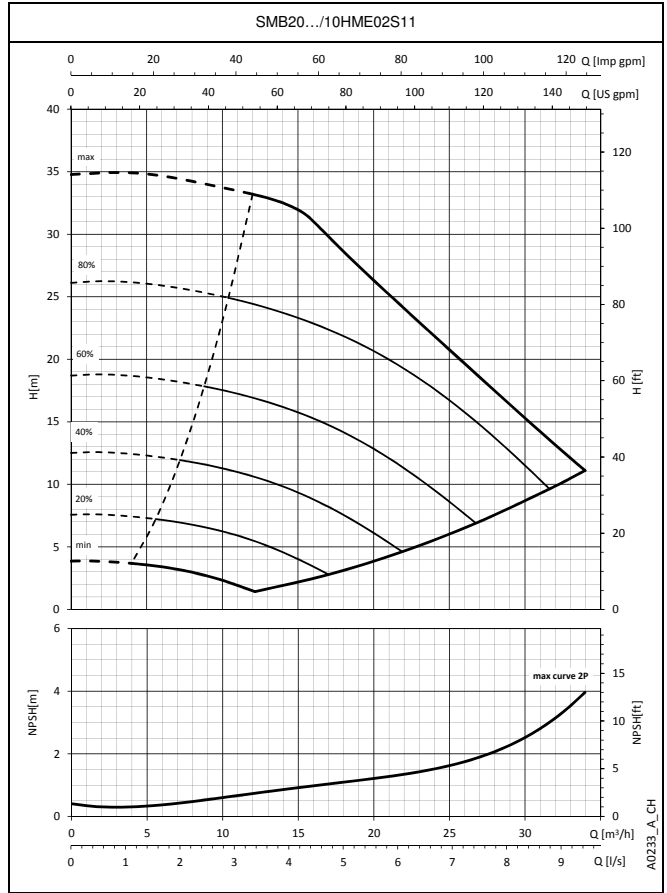
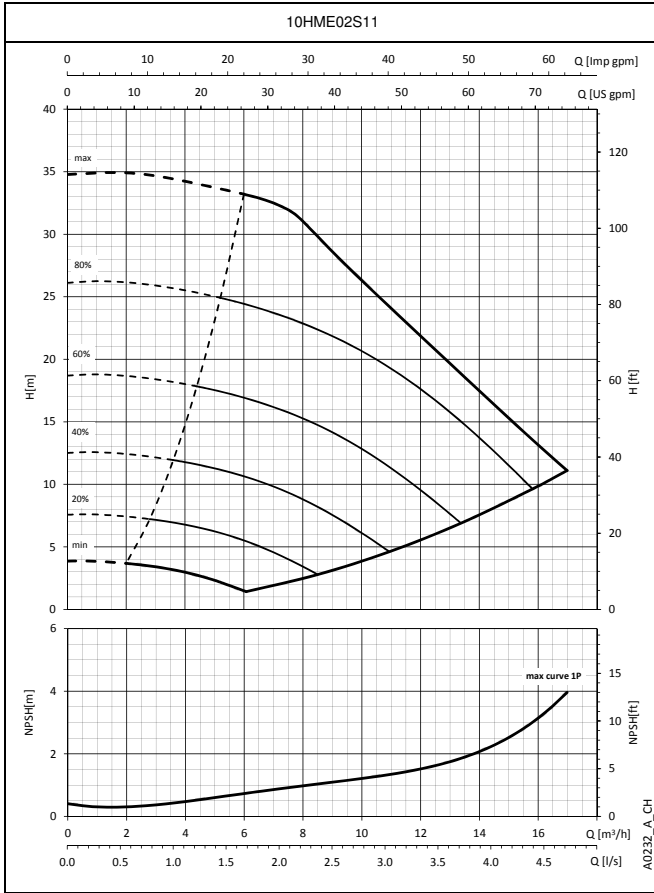

The performance curves do not take into account flow resistance in the valves and piping. The curves show the performance with one, two and three pumps running. These performances are valid for liquids with density  $\rho = 1 \text{ Kg/dm}^3$  and kinematic viscosity  $\nu = 1 \text{ mm}^2/\text{sec}$ . The declared NPSH values are laboratory values; for practical use we recommend increasing these values by 0,5 m.

## SMB.../HME BOOSTER SETS SERIES OPERATING CHARACTERISTICS

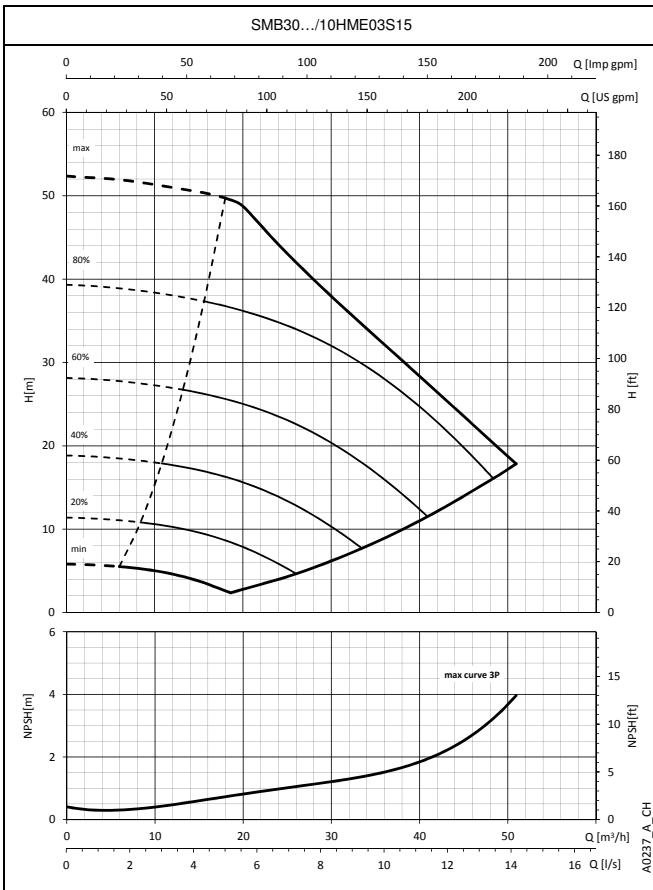
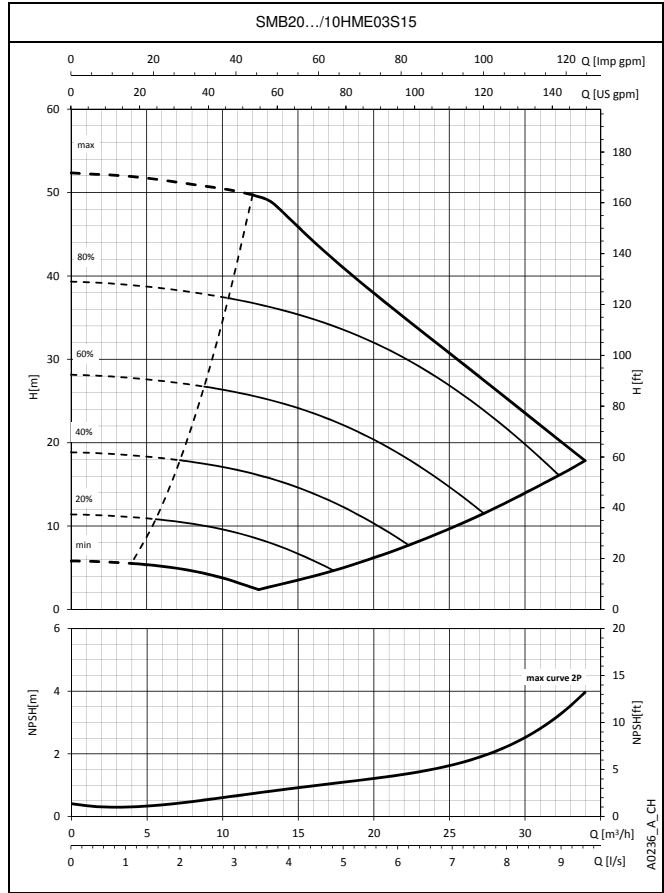
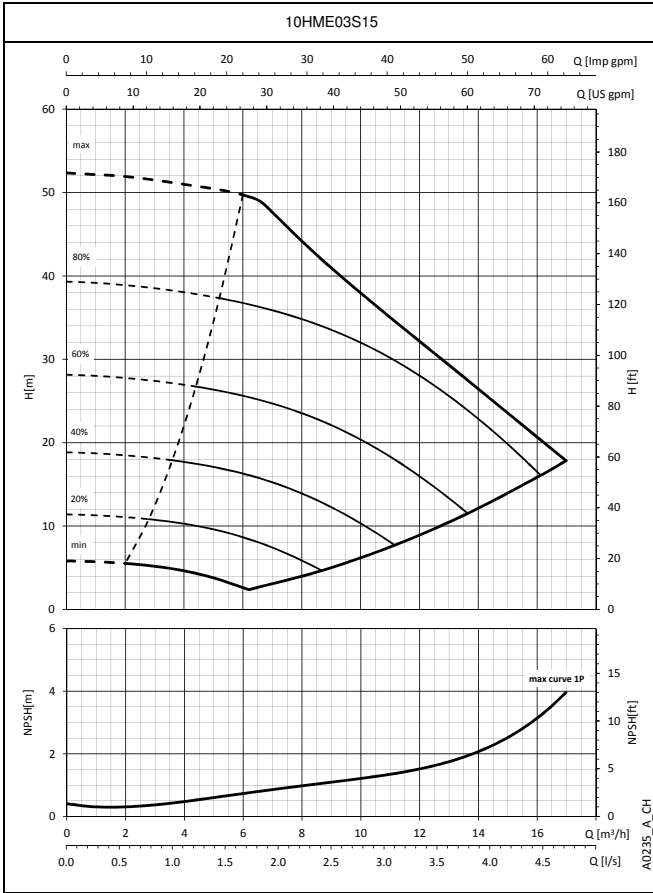

The performance curves do not take into account flow resistance in the valves and piping. The curves show the performance with one, two and three pumps running. These performances are valid for liquids with density  $\rho = 1 \text{ Kg/dm}^3$  and kinematic viscosity  $\nu = 1 \text{ mm}^2/\text{sec}$ . The declared NPSH values are laboratory values; for practical use we recommend increasing these values by 0,5 m.

**SMB.../HME BOOSTER SETS SERIES  
OPERATING CHARACTERISTICS**

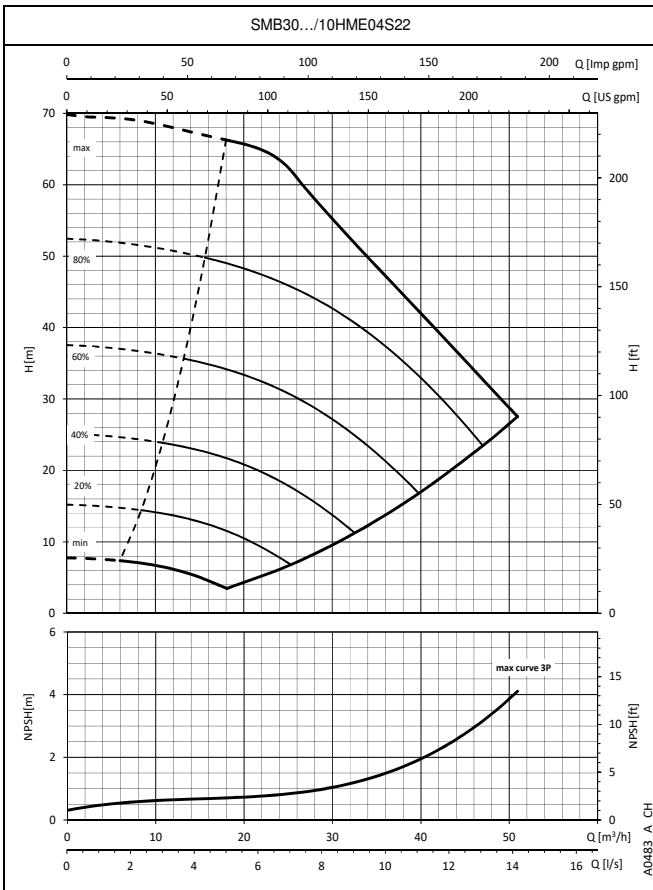
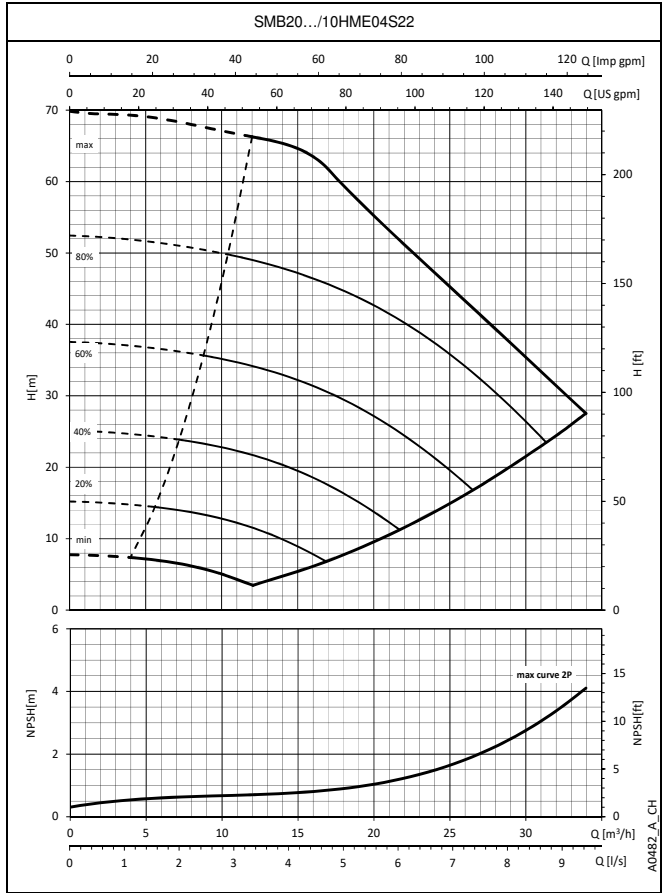
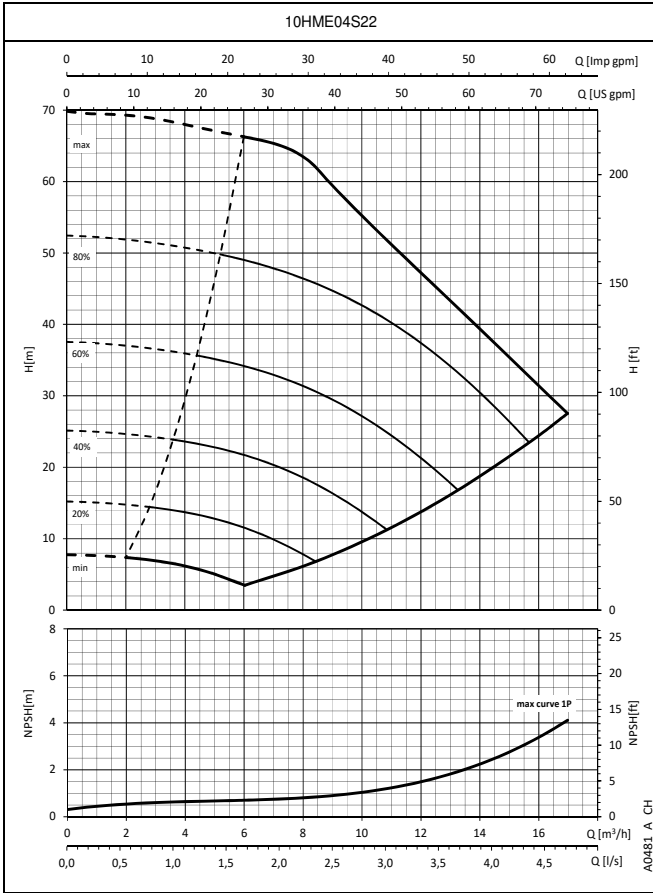

The performance curves do not take into account flow resistance in the valves and piping. The curves show the performance with one, two and three pumps running. These performances are valid for liquids with density  $\rho = 1 \text{ Kg/dm}^3$  and kinematic viscosity  $\nu = 1 \text{ mm}^2/\text{sec}$ . The declared NPSH values are laboratory values; for practical use we recommend increasing these values by 0,5 m.

## SMB.../HME BOOSTER SETS SERIES OPERATING CHARACTERISTICS

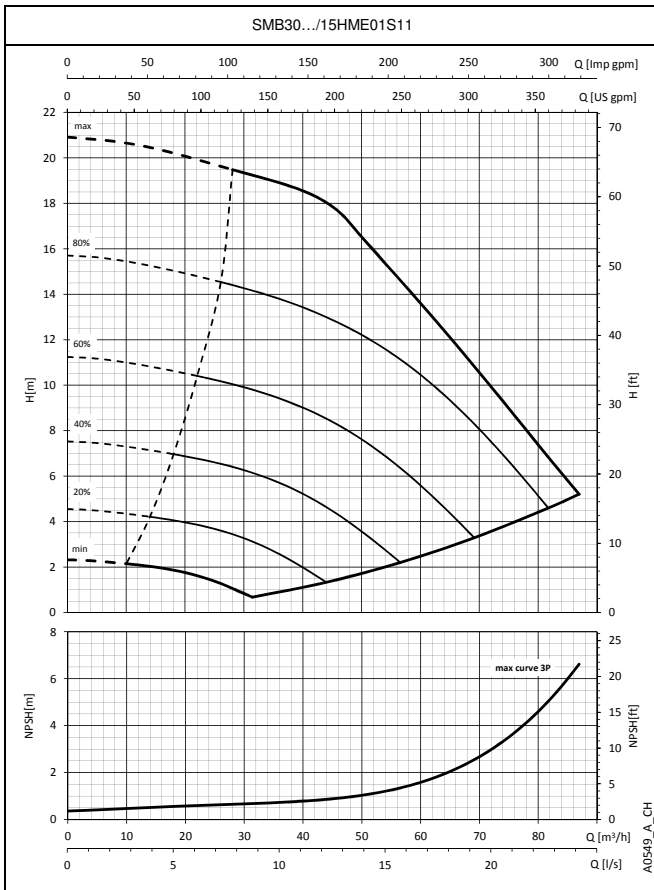
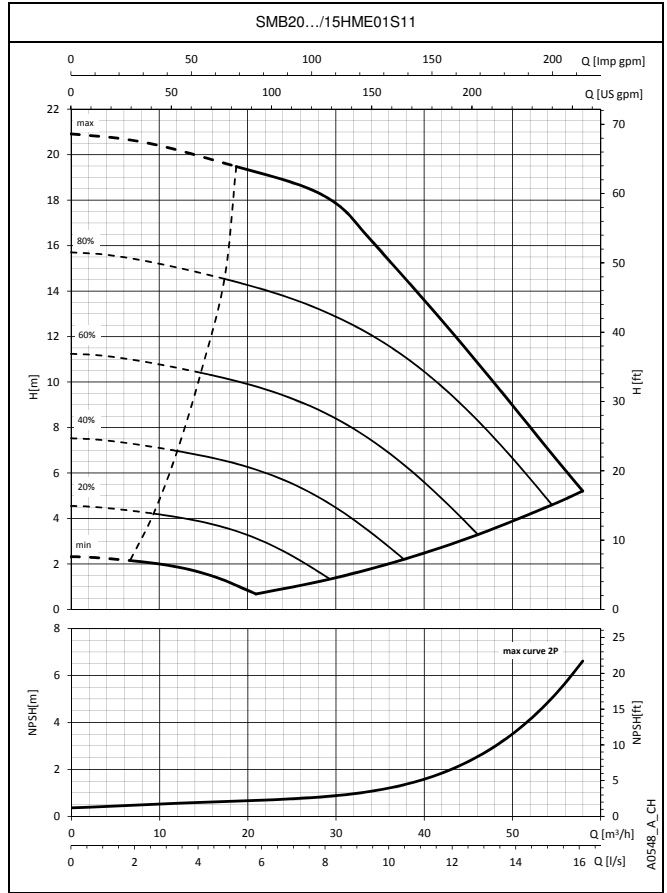
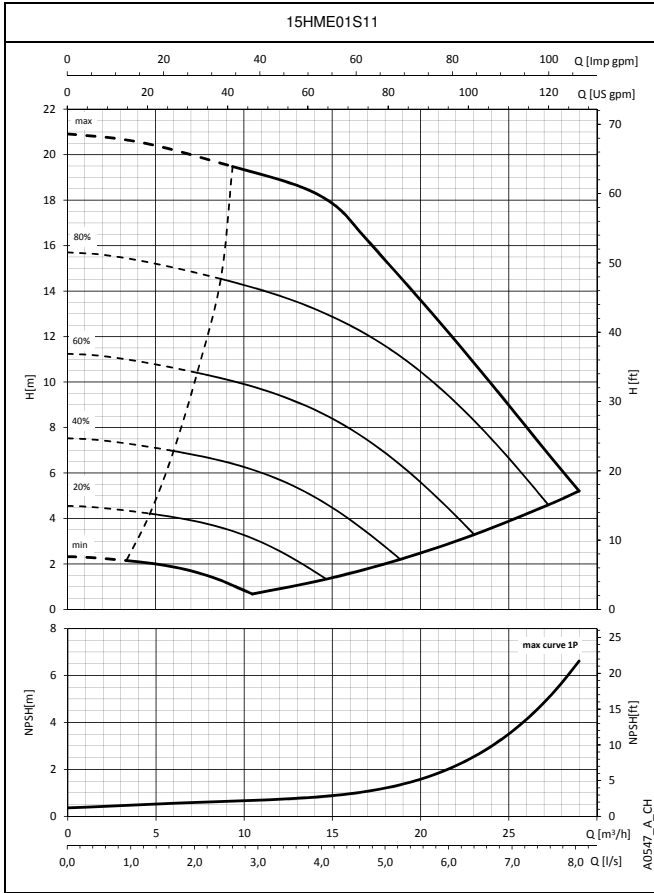

The performance curves do not take into account flow resistance in the valves and piping. The curves show the performance with one, two and three pumps running. These performances are valid for liquids with density  $\rho = 1 \text{ Kg/dm}^3$  and kinematic viscosity  $\nu = 1 \text{ mm}^2/\text{sec}$ . The declared NPSH values are laboratory values; for practical use we recommend increasing these values by 0,5 m.

## SMB.../HME BOOSTER SETS SERIES OPERATING CHARACTERISTICS

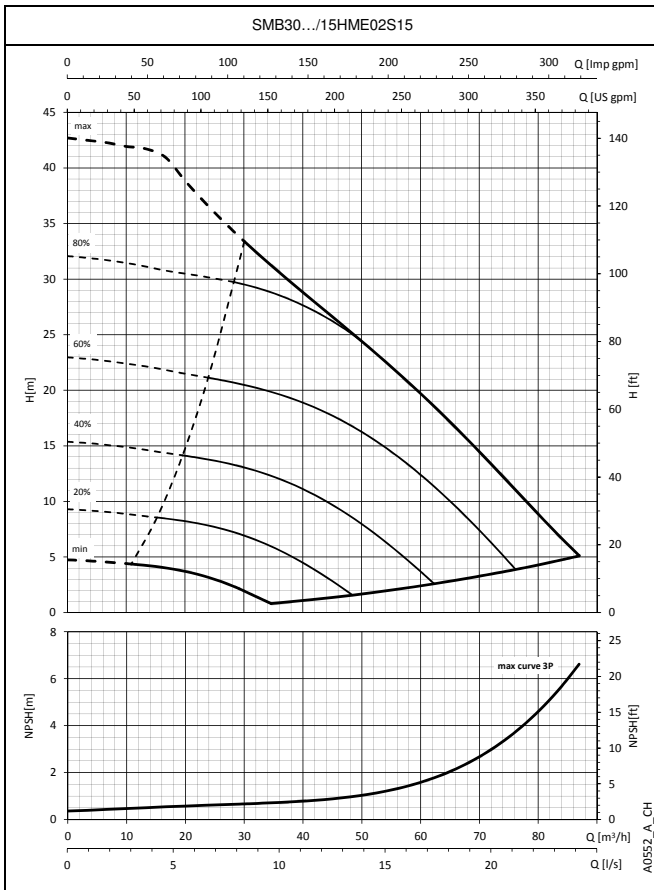
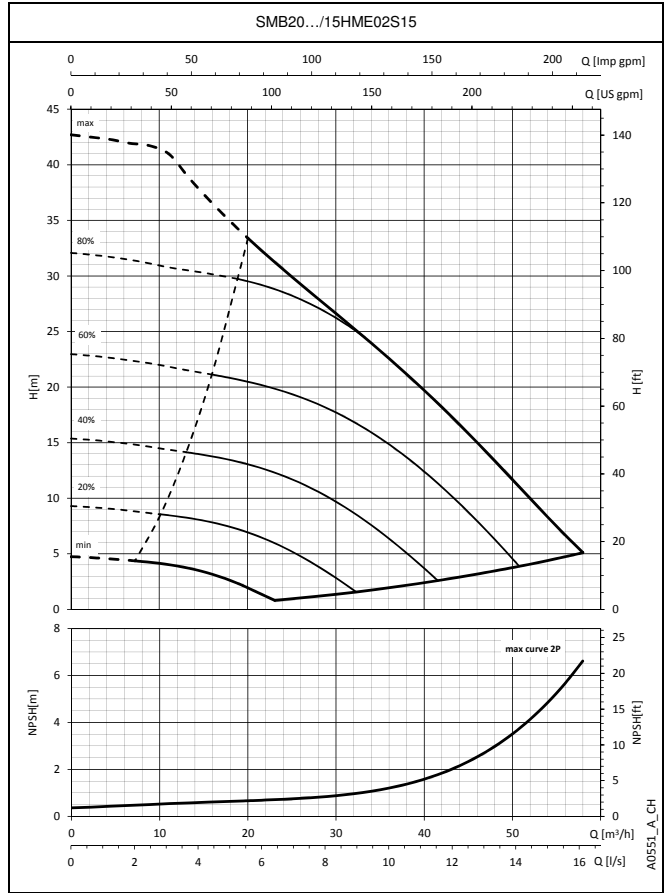
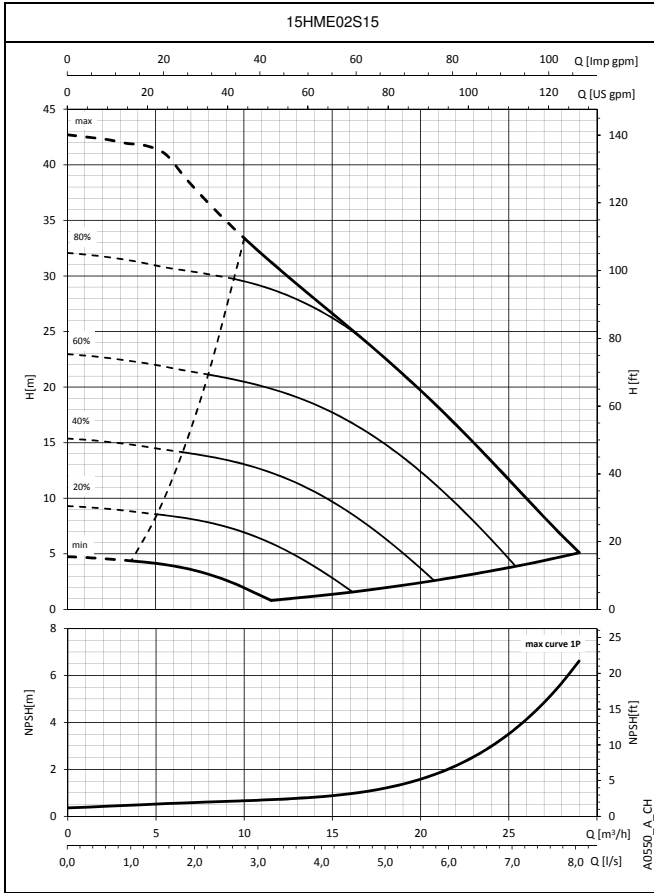

The performance curves do not take into account flow resistance in the valves and piping. The curves show the performance with one, two and three pumps running. These performances are valid for liquids with density  $\rho = 1 \text{ Kg/dm}^3$  and kinematic viscosity  $\nu = 1 \text{ mm}^2/\text{sec}$ . The declared NPSH values are laboratory values; for practical use we recommend increasing these values by 0,5 m.

## SMB.../HME BOOSTER SETS SERIES OPERATING CHARACTERISTICS

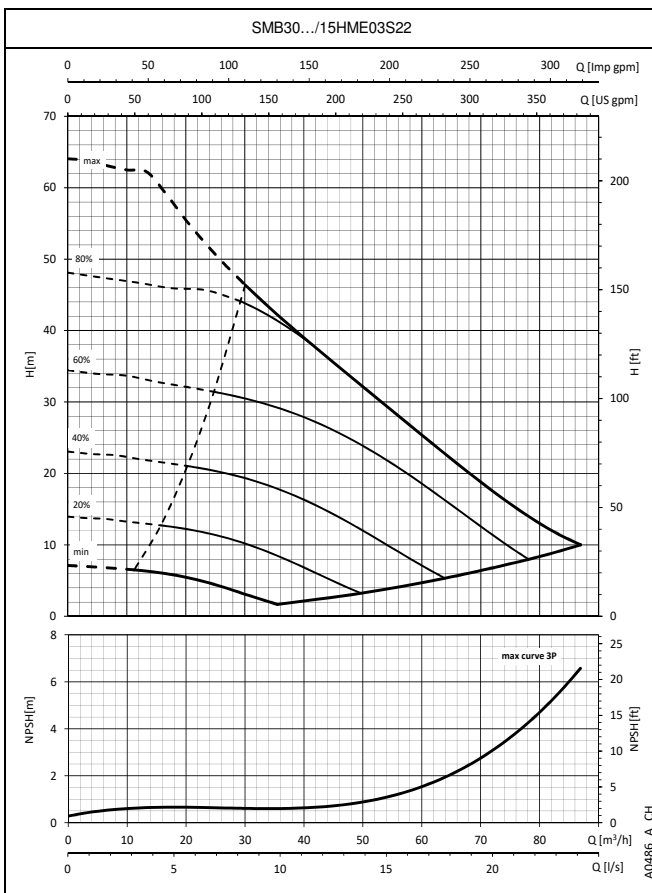
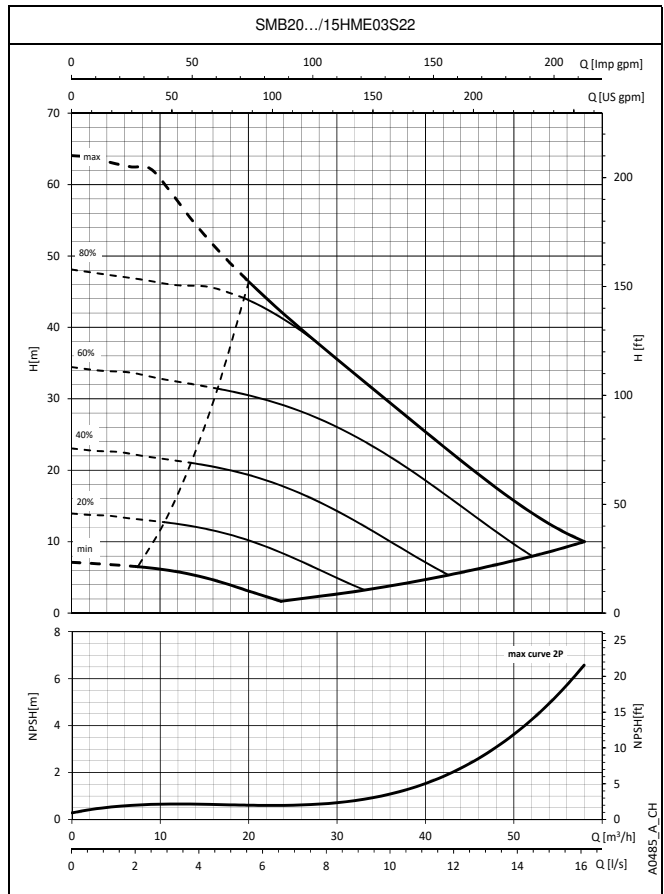
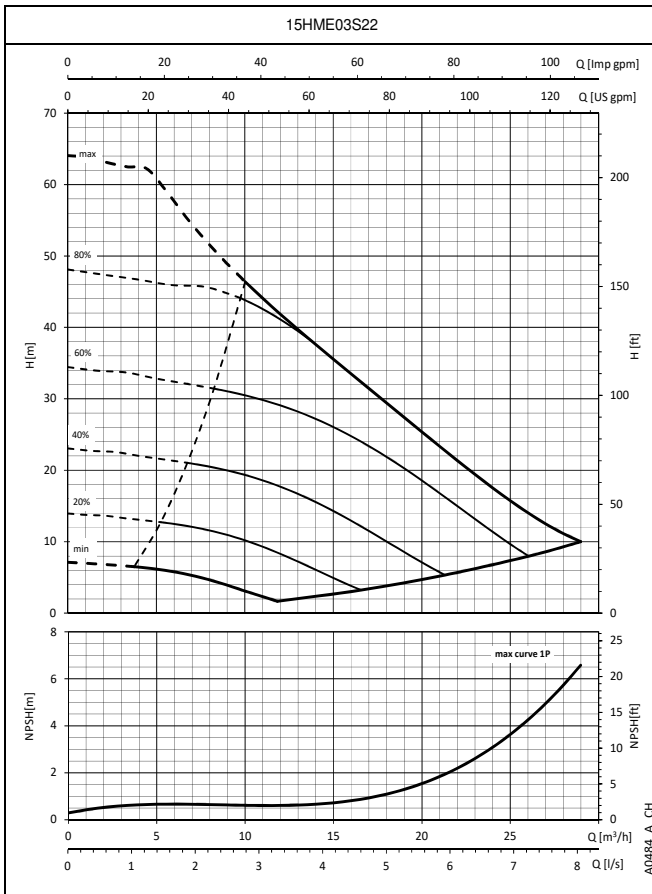

The performance curves do not take into account flow resistance in the valves and piping. The curves show the performance with one, two and three pumps running. These performances are valid for liquids with density  $\rho = 1 \text{ Kg/dm}^3$  and kinematic viscosity  $\nu = 1 \text{ mm}^2/\text{sec}$ . The declared NPSH values are laboratory values; for practical use we recommend increasing these values by 0,5 m.

## SMB20, SMB30 BOOSTER SETS SERIES

### Hc PRESSURE DROP CURVE

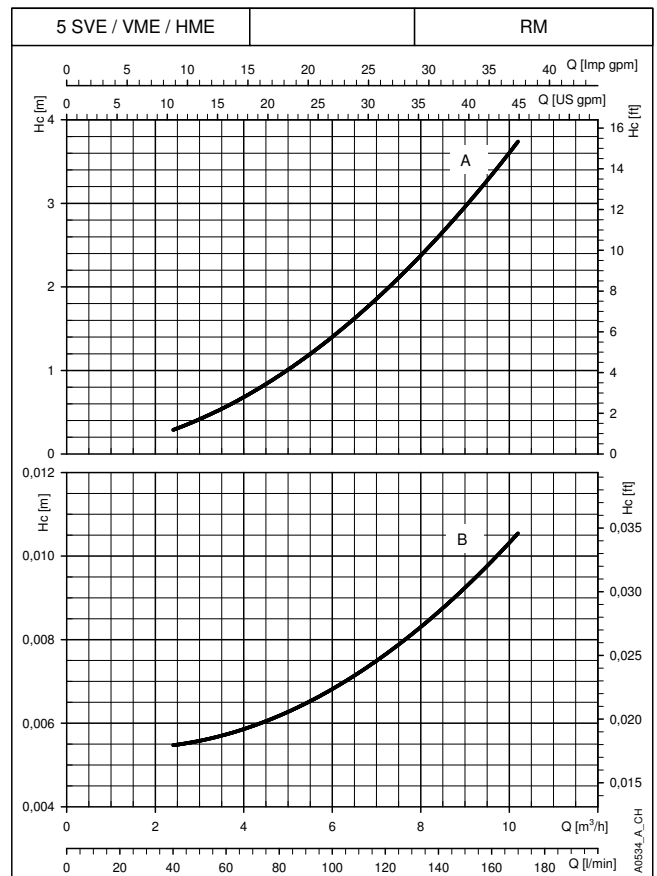
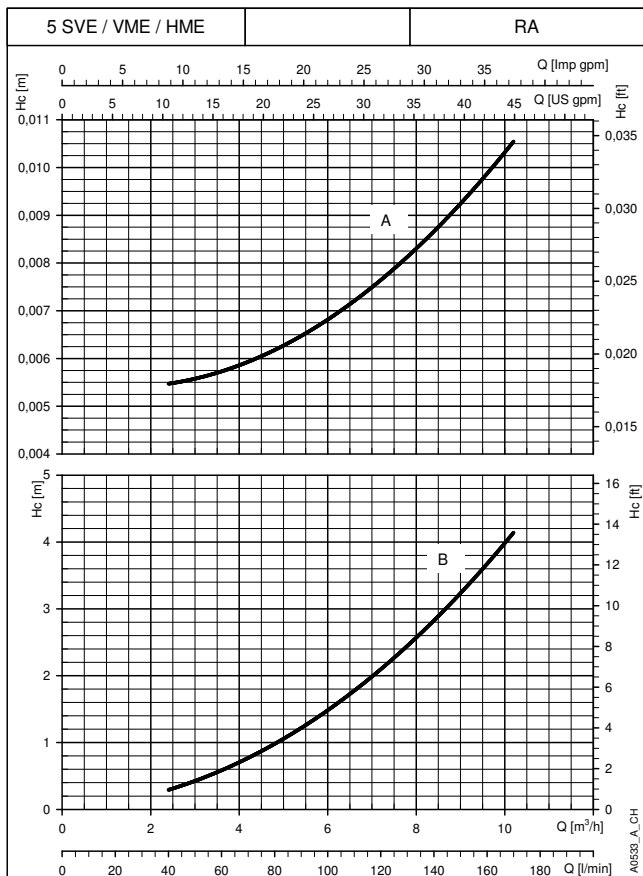
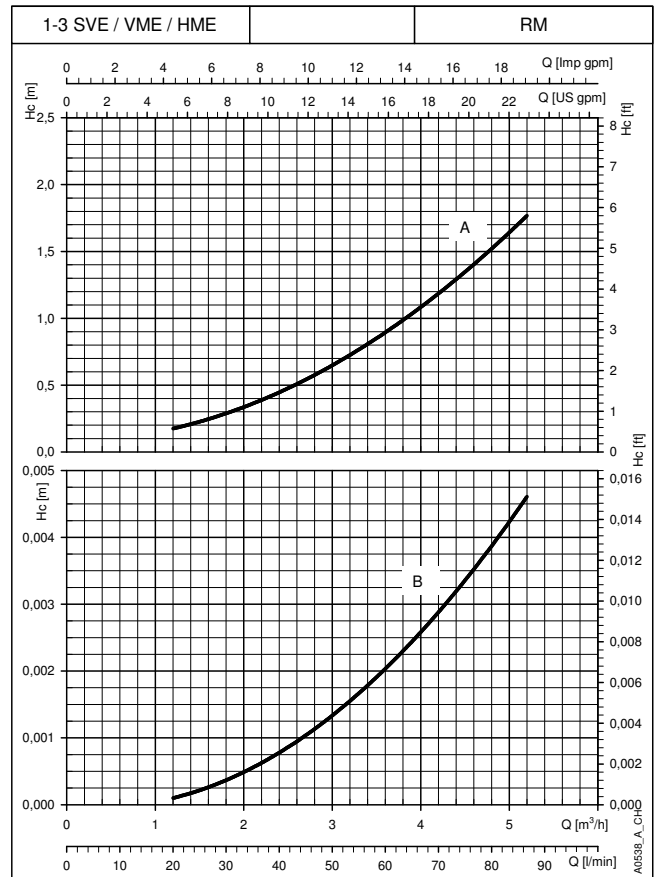
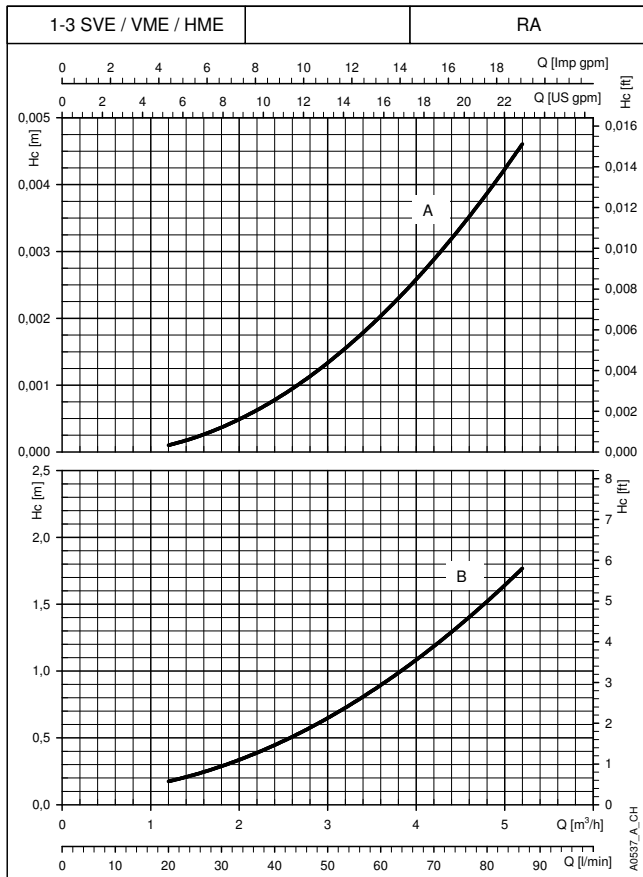

The declared curves are valid for liquids with density  $\rho = 1 \text{ Kg/dm}^3$  and kinematic viscosity  $\nu = 1 \text{ mm}^2/\text{sec}$ .  
Hc (A): Pressure drop curve on delivery side of the pump. Hc (B): Pressure drop curve on suction side of the pump.  
RA: check valve on suction side. RM: check valve on delivery side.  
The pressure drops do not consider the distributed pressure drops on the manifold.

## SMB20, SMB30 BOOSTER SETS SERIES

### H<sub>c</sub> PRESSURE DROP CURVE

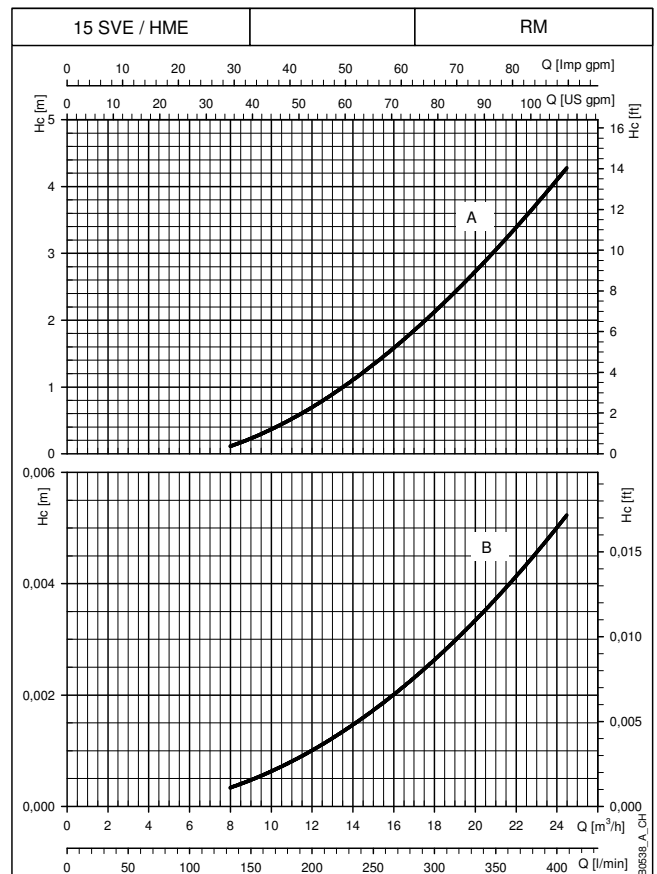
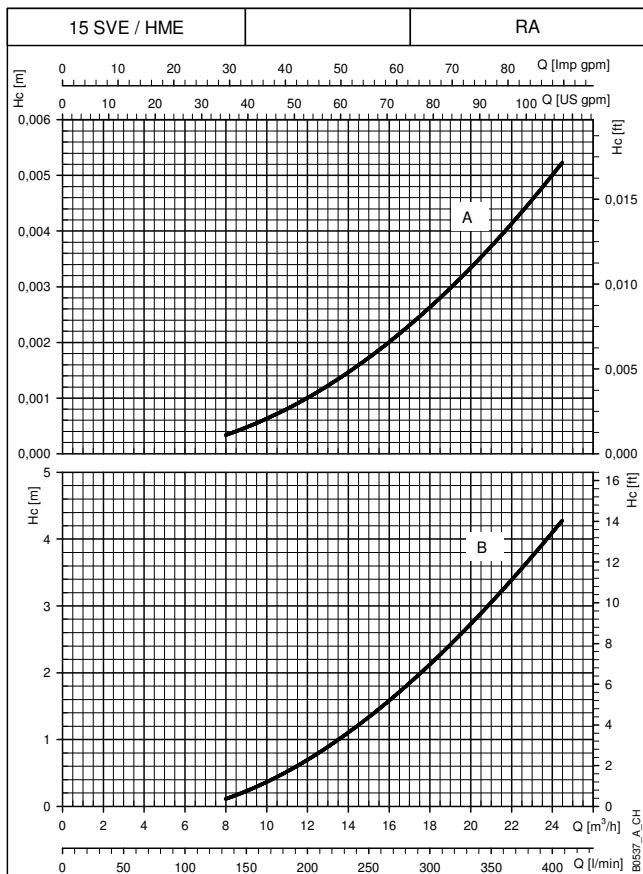
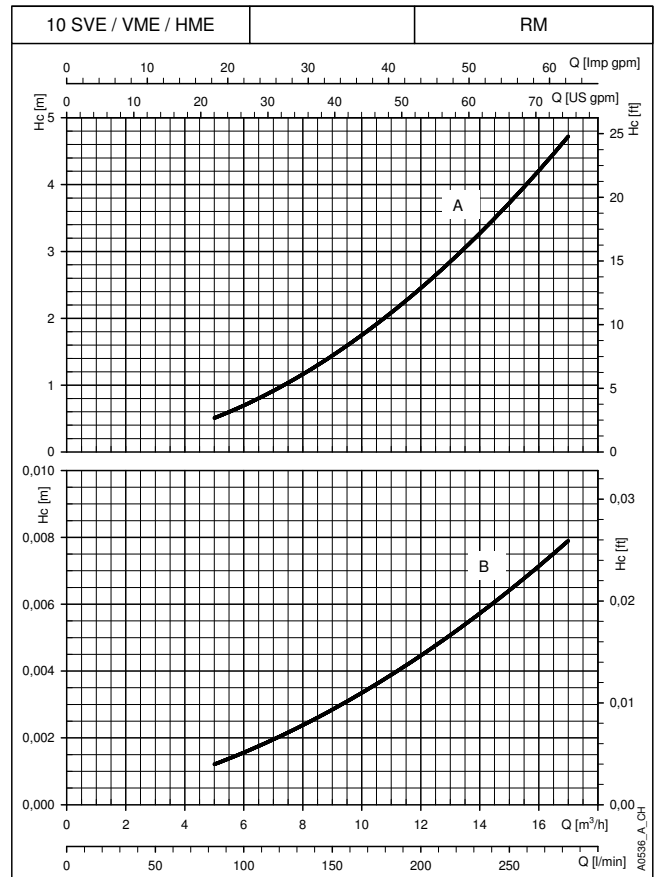
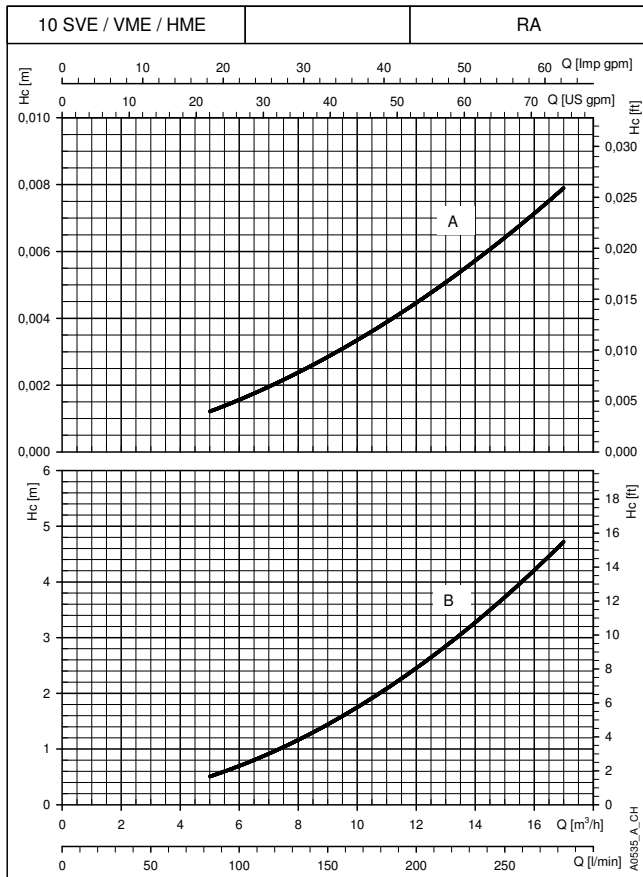

The declared curves are valid for liquids with density  $\rho = 1 \text{ Kg/dm}^3$  and kinematic viscosity  $\nu = 1 \text{ mm}^2/\text{sec}$ .  
H<sub>c</sub> (A): Pressure drop curve on delivery side of the pump. H<sub>c</sub> (B): Pressure drop curve on suction side of the pump.  
RA: check valve on suction side. RM: check valve on delivery side.  
The pressure drops do not consider the distributed pressure drops on the manifold.

**SMB20, SMB30 BOOSTER SETS SERIES**  
**H<sub>c</sub> PRESSURE DROP CURVE**

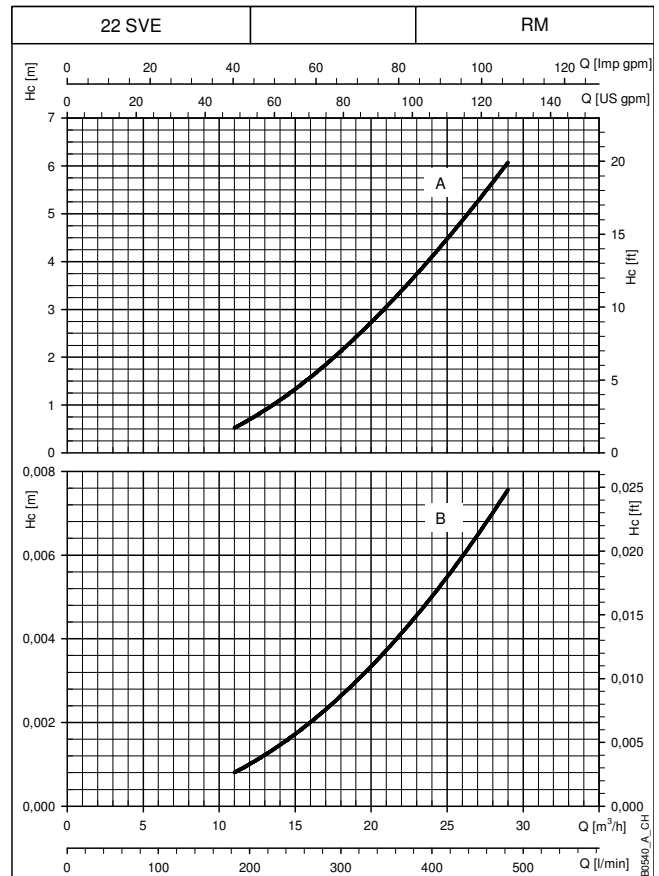
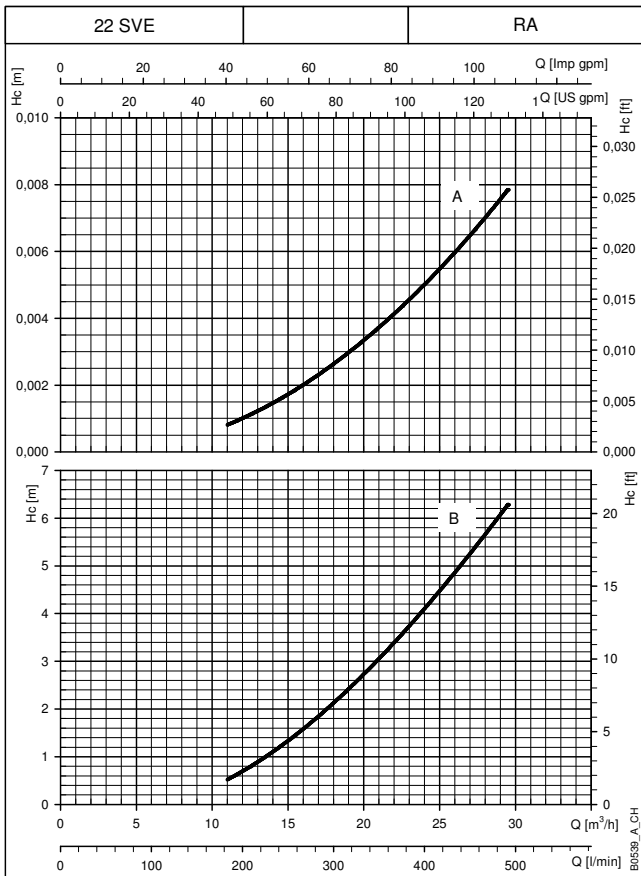

The declared curves are valid for liquids with density  $\rho = 1 \text{ Kg/dm}^3$  and kinematic viscosity  $\nu = 1 \text{ mm}^2/\text{sec}$ .  
H<sub>c</sub> (A): Pressure drop curve on delivery side of the pump. H<sub>c</sub> (B): Pressure drop curve on suction side of the pump.  
RA: check valve on suction side. RM: check valve on delivery side.  
The pressure drops do not consider the distributed pressure drops on the manifold.

# ACCESSORIES

## DIAPHRAGM EXPANSION VESSELS KITS

Booster sets have delivery manifolds with attachments for the installation of 8 or 24 litre diaphragm expansion vessels (hydrotube).

The caps for sealing any unused attachments are supplied with the set.

Any large size vessels can be connected to the unused end of the delivery manifold. For proper sizing of the vessel, please refer to the technical appendix.

Kits featuring the following accessories are **available on request**:

- expansion vessel.
- on-off valve.
- instructions sheet.
- packing.

Volume Litres	PN bar	DIMENSIONS (mm)			Materials		
		ø A	B	Valve	Diaphragm	Vessel	Valve
8	8	205	390	1" FF	EPDM	Painted steel	Nickel-plated brass
24	8	270	555	1" FF	EPDM	Painted steel	Nickel-plated brass
24	10	270	555	1" FF	EPDM	Painted steel	Nickel-plated brass
24	16	270	555	1" FF	EPDM	Painted steel	Nickel-plated brass
24	10	270	575	1" FF	Butyl	Stainless steel	AISI 316 stainless steel
20	25	270	555	1" FF	EPDM	Painted steel	Nickel-plated brass

Gcom-vmb-en\_c\_td

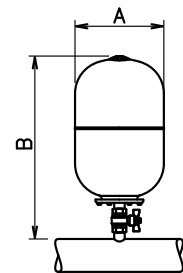

DETT-VASL\_A\_DD

## FLANGE KIT

Manifolds are supplied with threaded attachments and caps for sealing the unused ends.

For these manifolds, stainless steel AISI 304 or 316 flanges for connection to the system are available on request.

### THREADED COUNTERFLANGES

KIT TYPE	DN	ø C	DIMENSIONS (mm)				HOLES			PN
			ø A	B	ø D	H	ø F	N°		
2"	50	Rp 2	125	16	165	24	18	4	25	
2" 1/2	65	Rp 2 1/2	145	16	185	23	18	4	16	
3"	80	Rp 3	160	17	200	27	18	8	16	

Gcom-ctf-tonde-f-en\_a\_td

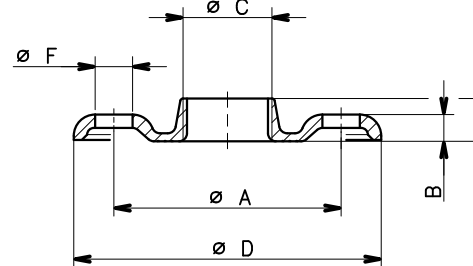

04430\_B\_DD

### WELD-ON COUNTERFLANGES

KIT TYPE	DN	ø C	DIMENSIONS (mm)				HOLES			PN
			ø A	B	ø D	ø F	N°			
2"	50	61	125	19	165	18	4	16		
2"1/2	65	77	145	20	185	18	4	16		
3"	80	90	160	20	200	18	8	16		
4"	100	116	180	22	220	18	8	16		
5"	125	141,5	210	22	250	18	8	16		
6"	150	170,5	240	24	285	22	8	16		
8"	200	221,5	295	26	340	22	12	16		
10"	250	276,5	355	29	405	26	12	16		
12"	300	327,5	410	32	460	26	12	16		

Gcom-ctf-tonde-s-en\_c\_td

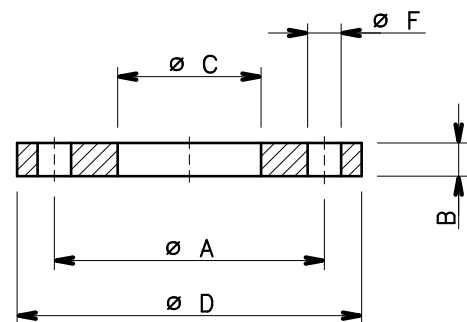

04431\_A\_DD

## ANTI-VIBRATION JOINT KIT

Anti-vibration joints, or compensation joints, can be used to absorb deformations, expansions, pipe noise and reduce water hammering. They can also withstand a high level of vacuum, which enables the absorption of negative expansions due to depression.

Due to its elasticity, the material can deform or expand as necessary, making installation easier, simpler and quicker, even when the piping is not aligned.

The drinking water certificates are valid for the standard booster configuration. Please check with your Sales representative the drinking water certifications applicable for boosters equipped with fitted joints.

For more information, please contact the sales network.

## RUBBER EXPANSION JOINT

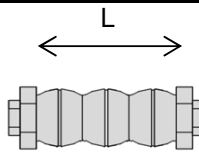
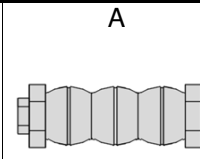
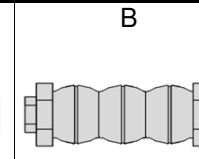
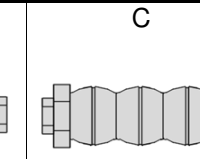
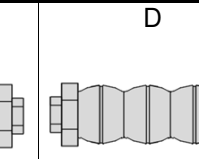
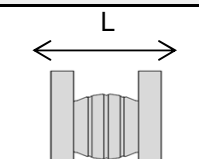
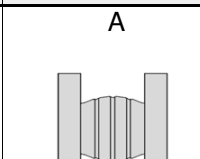
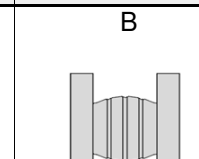
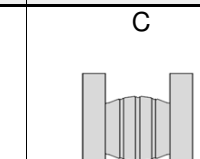
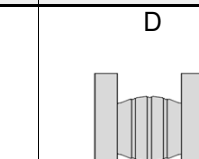
					
DN	( mm )	( mm )	( mm )	( mm )	( ° )
1"	200	25	6	23	30
1"1/4	200	25	6	23	30
1"1/2	200	25	6	23	30
2"	200	25	6	23	20
2"1/2	225	25	6	23	15
					
DN	( mm )	( mm )	( mm )	( mm )	( ° )
32	95	8	4	8	15
40	95	8	4	8	15
50	105	8	5	8	15
65	115	12	6	10	15
80	130	12	6	10	15
100	135	18	10	12	15
125	170	18	10	12	15
150	180	18	10	12	15
200	205	25	14	22	15
250	240	25	14	22	15
300	260	25	14	22	15
350	265	25	16	22	15
400	265	25	16	22	15
450	265	25	16	22	15
500	265	25	16	22	15

GD\_JOINT\_B\_TD

## LEGEND

- A = compression
- B = extension
- C = transverse
- D = angular movement

NOTE. A - B - C - D can not be cumulative

## PROTECTION SYSTEMS AGAINST DRY RUNNING

To avoid damaging the pumps, protection systems must be used to prevent it from dry running.

### FLOAT SWITCH PROTECTION

The float switch system is used for supplies from open tanks. The float switch immersed in the tank must be connected to the control panel.

If there is no water, the float switch opens the electrical contact and the electric pumps stop.

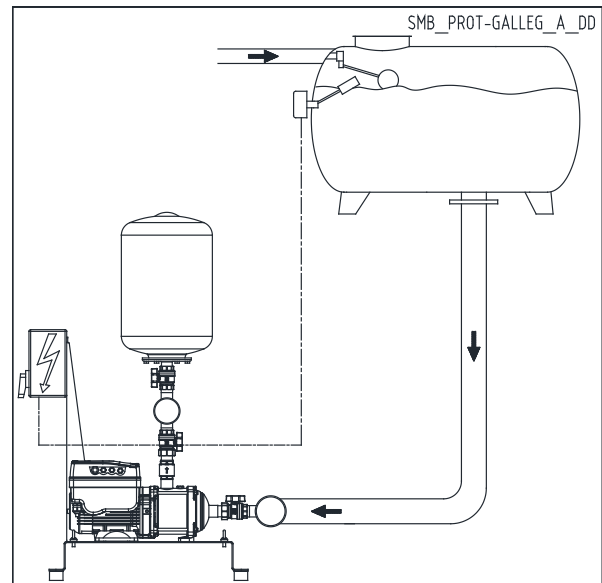

### ELECTRODE PROBE PROTECTION

The system with electrode probes is used for supplies from open tanks or wells.

Three probes are directly connected to the electric module with adjustable sensitivity that can be installed in the control panel.

If there is no water, the control circuit opens the electrical contact and the electric pumps stop.

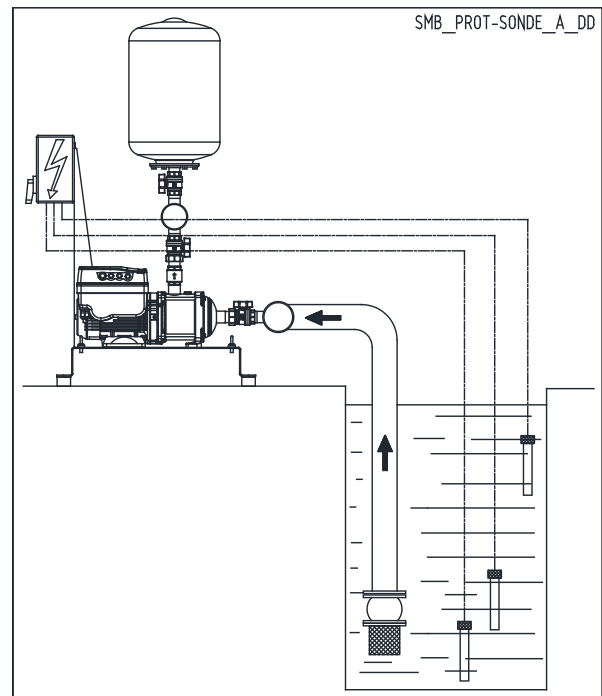

### MINIMUM PRESSURE SWITCH PROTECTION

The system with minimum pressure switch is used for water supplies from pressurised networks or tanks. The pressure switch is connected to the control panel. In case of water shortage, it opens the electric contact, causing the stop of the electric pumps.

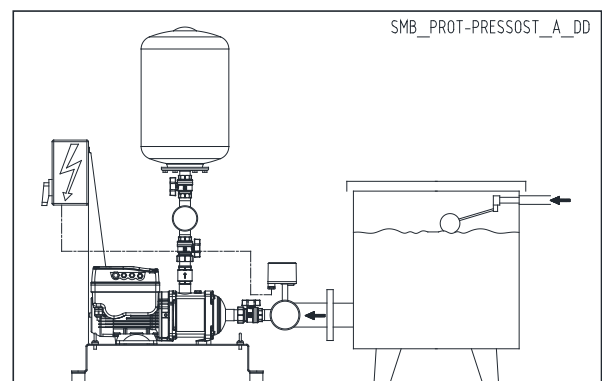

## PROTECTION SENSOR AGAINST DRY RUNNING



Sensor for detecting the presence of water based on the optoelectronic principle, therefore non-invasive and with no moving parts. The sensor features an electronic contact (on/off) which stops the pump if there is no water in the seal area.

The sensor opens the electric contact if there is no water after they factory-set delay (10 seconds) elapses. The sensor is supplied as a kit complete with 2 metres of cable, an EPDM O-ring gasket and a stainless steel adapter.

### General operating features

- **KIT SENSOR DRP-GP: 21÷27 Vca:** in the boosters sets the sensor is assembled on the suction manifold with a specific hydraulic fitting. (SMB20../DR1 and SMB30../DR1 booster set versions).  
21÷27 Vac, universal solid state output for external relay at 24 Vac (21÷27 Vac, 50 mA).
- **KIT SENSOR DRP-HV: 15÷25 Vdc:** the sensor can also be fitted directly on the filling cap of the e-SV pumps series. (SMB20../DR2, SMB30../DR3 booster set versions).  
15÷25 Vdc, NPN output at 25 V (10 mA) for HYDROVAR inverter and e-SM drive.
- Operation is independent of the hardness and conductivity of the water. The sensor cannot detect frozen liquids.

### Operating principle

Operation is based on the change in the refractive index on the surfaces. The optic sensor comprises a glass cap (C) containing a transmitter (T) and an infrared receiver (R).

If there is no liquid, all the infrared light emitted by the transmitter is internally reflected by the surface of the glass cap of the receiver. The electronic contact will be open.

If liquid is present, the refractive index of the surface changes. Most of the infrared light emitted by the transmitter is dispersed in the liquid. The receiver receives less light and the electronic contact is closed.

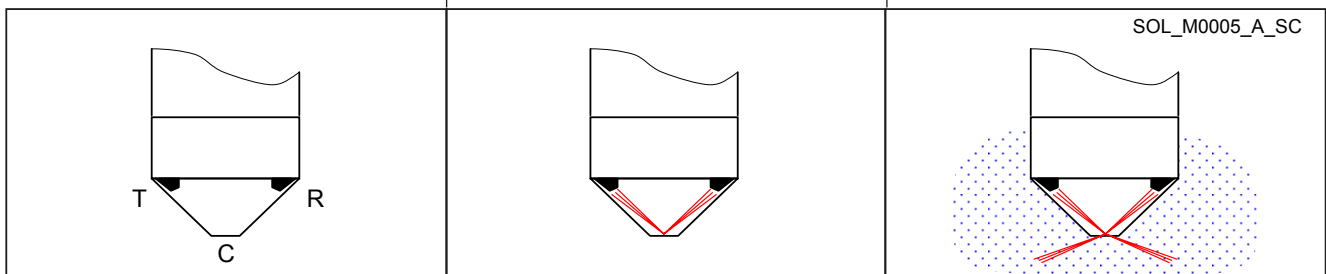

## SPECIFICATIONS

- Materials:
  - Body in AISI 316L stainless steel
  - Glass optic cap
  - EPDM gasket
- Liquids: clean water, demi water. Operation is not affected by the hardness and conductivity of the liquid. To check the suitability of other liquids, contact the Lowara technical assistance service providing the characteristics of the liquid.
- Temperature of liquid: -20°C ÷ +120°C (cannot be used to detect frozen liquids).
- Ambient temperature: -5°C ÷ +50°C
- Maximum pressure (PN): 25 bar
- Connector: 3/8" (3/8" x 1/2" adaptor plug included in the Kit)
- Dimensions: 27x 60 mm
- IP55 protection
- Electrical characteristics:
  - Input voltage SENSOR KIT DRP-GP: 21 ÷ 27 Vac  
SENSOR KIT DRP-HV: 15 ÷ 25 Vdc
  - Output SENSOR KIT DRP-GP: universal solid state 21 ÷ 27 Vac (50 mA) for 24 Vac external relay  
SENSOR KIT DRP-HV: NPN 25 V (10 mA) for HYDROVAR™ inverter and e-SM drive
  - Alarm delay: 10 seconds (factory setting)
  - FROR cable 4 x 0,34 mm<sup>2</sup> (PVC-CEI 20-22) 2 metres long.

## WIRING DIAGRAM

### KIT SENSOR DRP-GP (code 109394610)

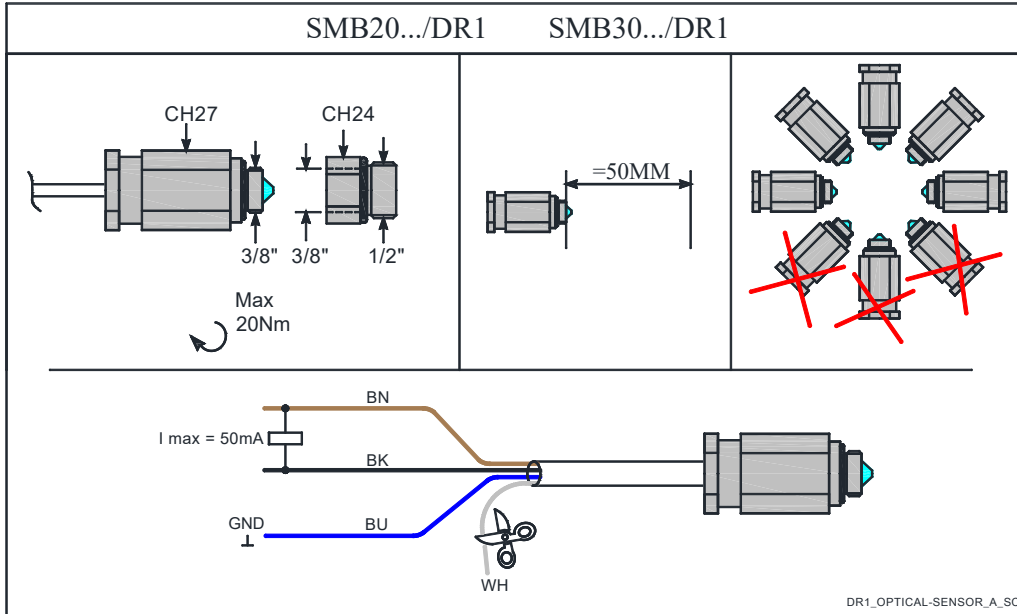

### KIT SENSOR DRP-HV (code 109394600)

The sensor can be directly mounted on the filling plug of the e-SV pumps.  
 For the 33, 46, 66, 92, 125SV series, the 3/8" x 1/2" adaptor ring included in the kit must also be installed.

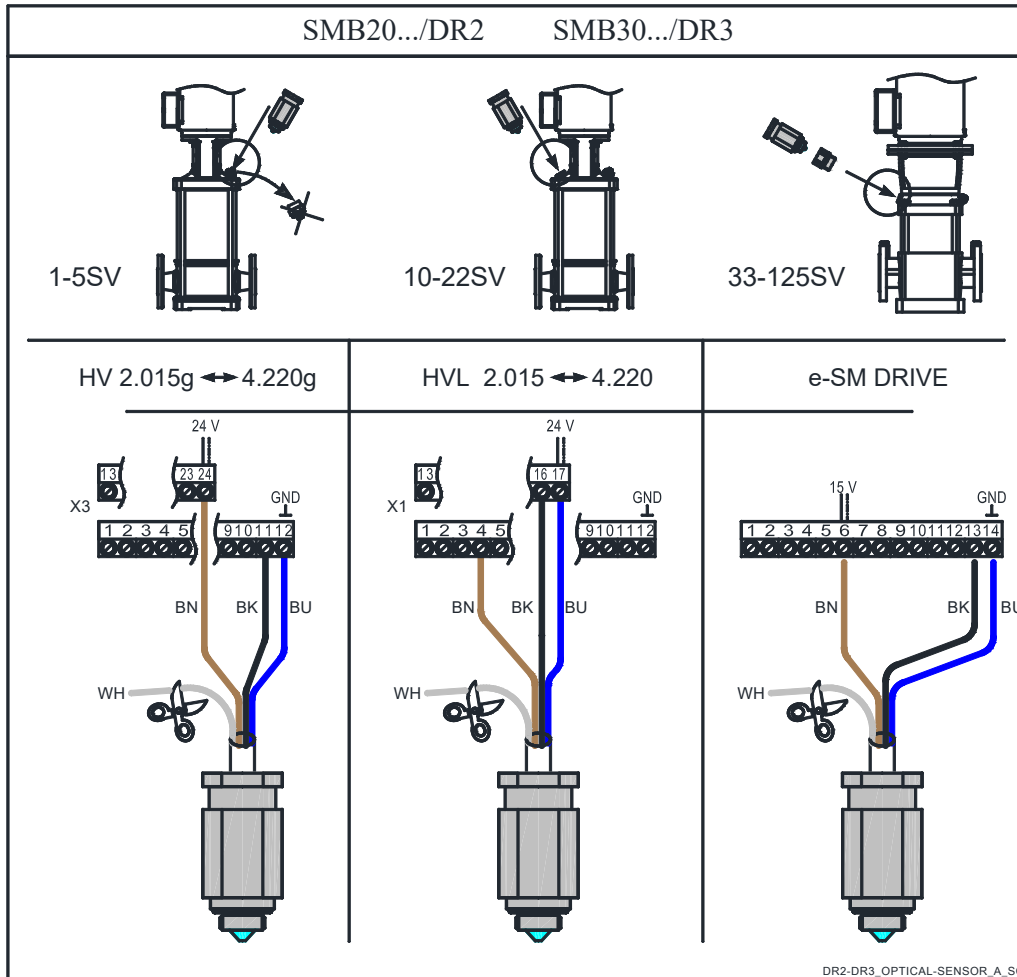

# **TECHNICAL APPENDIX**

**VAPOUR PRESSURE**  
**VAPOUR PRESSURE  $p_s$  AND  $\rho$  DENSITY OF WATER TABLE**

t °C	T K	$p_s$ bar	$\rho$ kg/dm <sup>3</sup>	t °C	T K	$p_s$ bar	$\rho$ kg/dm <sup>3</sup>	t °C	T K	$p_s$ bar	$\rho$ kg/dm <sup>3</sup>
0	273,15	0,00611	0,9998	55	328,15	0,15741	0,9857	120	393,15	1,9854	0,9429
1	274,15	0,00657	0,9999	56	329,15	0,16511	0,9852	122	395,15	2,1145	0,9412
2	275,15	0,00706	0,9999	57	330,15	0,17313	0,9846	124	397,15	2,2504	0,9396
3	276,15	0,00758	0,9999	58	331,15	0,18147	0,9842	126	399,15	2,3933	0,9379
4	277,15	0,00813	1,0000	59	332,15	0,19016	0,9837	128	401,15	2,5435	0,9362
5	278,15	0,00872	1,0000	60	333,15	0,1992	0,9832	130	403,15	2,7013	0,9346
6	279,15	0,00935	1,0000	61	334,15	0,2086	0,9826	132	405,15	2,867	0,9328
7	280,15	0,01001	0,9999	62	335,15	0,2184	0,9821	134	407,15	3,041	0,9311
8	281,15	0,01072	0,9999	63	336,15	0,2286	0,9816	136	409,15	3,223	0,9294
9	282,15	0,01147	0,9998	64	337,15	0,2391	0,9811	138	411,15	3,414	0,9276
10	283,15	0,01227	0,9997	65	338,15	0,2501	0,9805	140	413,15	3,614	0,9258
11	284,15	0,01312	0,9997	66	339,15	0,2615	0,9799	145	418,15	4,155	0,9214
12	285,15	0,01401	0,9996	67	340,15	0,2733	0,9793	155	428,15	5,433	0,9121
13	286,15	0,01497	0,9994	68	341,15	0,2856	0,9788	160	433,15	6,181	0,9073
14	287,15	0,01597	0,9993	69	342,15	0,2984	0,9782	165	438,15	7,008	0,9024
15	288,15	0,01704	0,9992	70	343,15	0,3116	0,9777	170	443,15	7,920	0,8973
16	289,15	0,01817	0,9990	71	344,15	0,3253	0,9770	175	448,15	8,924	0,8921
17	290,15	0,01936	0,9988	72	345,15	0,3396	0,9765	180	453,15	10,027	0,8869
18	291,15	0,02062	0,9987	73	346,15	0,3543	0,9760	185	458,15	11,233	0,8815
19	292,15	0,02196	0,9985	74	347,15	0,3696	0,9753	190	463,15	12,551	0,8760
20	293,15	0,02337	0,9983	75	348,15	0,3855	0,9748	195	468,15	13,987	0,8704
21	294,15	0,24850	0,9981	76	349,15	0,4019	0,9741	200	473,15	15,550	0,8647
22	295,15	0,02642	0,9978	77	350,15	0,4189	0,9735	205	478,15	17,243	0,8588
23	296,15	0,02808	0,9976	78	351,15	0,4365	0,9729	210	483,15	19,077	0,8528
24	297,15	0,02982	0,9974	79	352,15	0,4547	0,9723	215	488,15	21,060	0,8467
25	298,15	0,03166	0,9971	80	353,15	0,4736	0,9716	220	493,15	23,198	0,8403
26	299,15	0,03360	0,9968	81	354,15	0,4931	0,9710	225	498,15	25,501	0,8339
27	300,15	0,03564	0,9966	82	355,15	0,5133	0,9704	230	503,15	27,976	0,8273
28	301,15	0,03778	0,9963	83	356,15	0,5342	0,9697	235	508,15	30,632	0,8205
29	302,15	0,04004	0,9960	84	357,15	0,5557	0,9691	240	513,15	33,478	0,8136
30	303,15	0,04241	0,9957	85	358,15	0,5780	0,9684	245	518,15	36,523	0,8065
31	304,15	0,04491	0,9954	86	359,15	0,6011	0,9678	250	523,15	39,776	0,7992
32	305,15	0,04753	0,9951	87	360,15	0,6249	0,9671	255	528,15	43,246	0,7916
33	306,15	0,05029	0,9947	88	361,15	0,6495	0,9665	260	533,15	46,943	0,7839
34	307,15	0,05318	0,9944	89	362,15	0,6749	0,9658	265	538,15	50,877	0,7759
35	308,15	0,05622	0,9940	90	363,15	0,7011	0,9652	270	543,15	55,058	0,7678
36	309,15	0,05940	0,9937	91	364,15	0,7281	0,9644	275	548,15	59,496	0,7593
37	310,15	0,06274	0,9933	92	365,15	0,7561	0,9638	280	553,15	64,202	0,7505
38	311,15	0,06624	0,9930	93	366,15	0,7849	0,9630	285	558,15	69,186	0,7415
39	312,15	0,06991	0,9927	94	367,15	0,8146	0,9624	290	563,15	74,461	0,7321
40	313,15	0,07375	0,9923	95	368,15	0,8453	0,9616	295	568,15	80,037	0,7223
41	314,15	0,07777	0,9919	96	369,15	0,8769	0,9610	300	573,15	85,927	0,7122
42	315,15	0,08198	0,9915	97	370,15	0,9094	0,9602	305	578,15	92,144	0,7017
43	316,15	0,09639	0,9911	98	371,15	0,9430	0,9596	310	583,15	98,70	0,6906
44	317,15	0,09100	0,9907	99	372,15	0,9776	0,9586	315	588,15	105,61	0,6791
45	318,15	0,09582	0,9902	100	373,15	1,0133	0,9581	320	593,15	112,89	0,6669
46	319,15	0,10086	0,9898	102	375,15	1,0878	0,9567	325	598,15	120,56	0,6541
47	320,15	0,10612	0,9894	104	377,15	1,1668	0,9552	330	603,15	128,63	0,6404
48	321,15	0,11162	0,9889	106	379,15	1,2504	0,9537	340	613,15	146,05	0,6102
49	322,15	0,11736	0,9884	108	381,15	1,3390	0,9522	350	623,15	165,35	0,5743
50	323,15	0,12335	0,9880	110	383,15	1,4327	0,9507	360	633,15	186,75	0,5275
51	324,15	0,12961	0,9876	112	385,15	1,5316	0,9491	370	643,15	210,54	0,4518
52	325,15	0,13613	0,9871	114	387,15	1,6362	0,9476	374,15	647,30	221,20	0,3154
53	326,15	0,14293	0,9862	116	389,15	1,7465	0,9460				
54	327,15	0,15002	0,9862	118	391,15	1,8628	0,9445				

G-at\_npsb\_b\_sc

## TANK

### CHOOSING AND SIZING THE SURGE TANK

The purpose of the surge tank is to limit the number of hourly starts of the pumps, placing part of its stock of water, which is maintained under pressure by the air above it, at the disposal of the system.

The surge tank can be of the air cushion or diaphragm type.

In the air cushion version there is no clear separation between air and water.

Since part of the air tends to mix with water, it is necessary to restore it by means of air supply units or a compressor.

In the diaphragm version, neither air supply units nor compressor are needed, as contact between air and water is prevented by a flexible diaphragm inside the tank.

The following method, which is used to determine the volume of a surge tank, is valid both for horizontal and vertical surge tanks.

When calculating the volume of the surge tank, it is generally sufficient to consider the first pump only.

### DIAPHRAGM TANK

If you decide to use a diaphragm tank, the volume will be lower than that of the air-cushion tank. It can be calculated with the following formula:

$$V_m = \frac{Q_p}{4 \times Z} \times \frac{1}{1 - \frac{(P_{min} - 2)}{P_{max}}}$$

where:

$V_m$  = Total volume of the air-cushion surge tank in  $m^3$

$Q_p$  = Average pump flow rate in  $m^3/h$

$P_{max}$  = Maximum pressure setting (wcm)

$P_{min}$  = Minimum pressure setting (wcm)

$Z$  = Maximum number of starts per hour allowed by the motor

**Example:**

22SV10F110T electric pump

$P_{max}$  = 23 wcm

$P_{min}$  = 15 wcm

$Q_p$  = 20  $m^3/h$

$Z$  = 25

$$V_m = \frac{Q_p}{4 \times Z} \times \frac{1}{1 - \frac{(P_{min} - 2)}{P_{max}}} = 0,46 \text{ m}^3$$

A 500-litre surge tank is therefore required.

## TANK

### PERFORMANCE WITH VARYING SPEED EQUIVALENCE RELATIONS

Fitting the electric pump with a frequency converter makes it possible to vary the pump rotation speed, normally according to the system pressure parameter. **Variations in electric pump speed** result in **modified performances** according to the equivalence relations.

Flow rate	$\frac{Q1}{Q2} = \left[ \frac{n1}{n2} \right]$
Head	$\frac{H1}{H2} = \left[ \frac{n1}{n2} \right]^2$
Power	$\frac{P1}{P2} = \left[ \frac{n1}{n2} \right]^3$

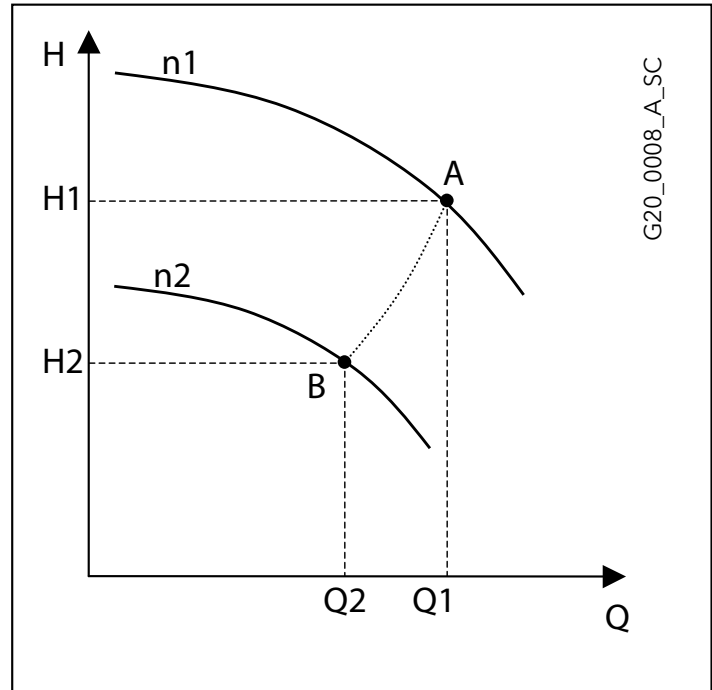

n1 = initial speed;      n2= speed required.  
 Q1 = initial flow rate;    Q2= flow rate required.  
 H1 = initial head;      H2= head required.  
 P1 = initial power;      P2= power required

**Frequency ratios** can be used instead of speed in practical applications, keeping 30 Hz as the bottom limit.

**Example** : 2-pole 50 Hz electric pump n1 =2900 rpm (point A)

Flow rate (A) = 100 l/min; Head (A) = 50 m

By reducing the frequency to 30 Hz the speed is reduced to approx. n2 = 1740 rpm (point B)

Flow rate (B) = 60 l/min; Head (B) = 18 m

The power of the new work point B is cut to about 22% of the initial power.

### SIZING THE DIAPHRAGM TANK IN SYSTEMS WITH SPEED VARIATION

**Variable speed** booster sets need **smaller tanks** compared to traditional systems. Generally speaking, a tank with a litre capacity of just 10% of the nominal capacity of a single pump, expressed in litres per minute, is needed. The **gradual starting** of the pumps controlled by the frequency converters reduces the need to limit the number of hourly starts; the main purpose of the tank is to compensate for small system losses, stabilize the pressure and make up for pressure variations caused by sudden demand.

Make the following calculation:

Set made up of three electric pumps, each with a maximum flow rate of 400 l/min, for a total capacity of 1200 l/min. The **volume** required for the tank is 40 litres. This size can be obtained by using two 24-litre tanks mounted directly onto the set's manifold.

The calculation establishes the minimum value needed for proper operation.



## FLOW RESISTANCE TABLE OF FLOW RESISTANCE IN BENDS, VALVES AND GATES

The flow resistance is calculated using the equivalent pipeline length method according to the table below:

ACCESSORY TYPE	DN											
	25	32	40	50	65	80	100	125	150	200	250	300
	Equivalent pipeline length (m)											
45° bend	0,2	0,2	0,4	0,4	0,6	0,6	0,9	1,1	1,5	1,9	2,4	2,8
90° bend	0,4	0,6	0,9	1,1	1,3	1,5	2,1	2,6	3,0	3,9	4,7	5,8
90° smooth bend	0,4	0,4	0,4	0,6	0,9	1,1	1,3	1,7	1,9	2,8	3,4	3,9
Union tee or cross	1,1	1,3	1,7	2,1	2,6	3,2	4,3	5,3	6,4	7,5	10,7	12,8
Gate valve	-	-	-	0,2	0,2	0,2	0,4	0,4	0,6	0,9	1,1	1,3
Foot check valve	1,1	1,5	1,9	2,4	3,0	3,4	4,7	5,9	7,4	9,6	11,8	13,9
Non return valve	1,1	1,5	1,9	2,4	3,0	3,4	4,7	5,9	7,4	9,6	11,8	13,9

G-a-pcv-en\_b\_th

The table is valid for the Hazen Williams coefficient  $C=100$  (cast iron pipework)  
for galvanized steel or painted steel multiply the values by 0,71;  
for stainless steel and copper multiply the values by 0,54;  
for Pvc and PE multiply the values by 0,47.

When the **equivalent pipeline length** has been determined, the flow resistance is obtained from the table in the previous page.

The values given are guideline values which are bound to vary slightly according to the model, especially for gate valves and non-return valves, for which it is a good idea to check the values supplied by manufacturers.

## VOLUMETRIC CAPACITY

Litres per minute l/min	Cubic metres per hour m <sup>3</sup> /h	Cubic feet per hour ft <sup>3</sup> /h	Cubic feet per minute ft <sup>3</sup> /min	Imperial gallon per minute Imp. gal/min	U.S. gallon per minute US gal/min
<b>1,000</b>	0,0600	2,1189	0,0353	0,2200	0,2642
16,6667	<b>1,000</b>	35,3147	0,5886	3,6662	4,4029
0,4719	0,0283	<b>1,000</b>	0,0167	0,1038	0,1247
28,3168	1,6990	60,0000	<b>1,000</b>	6,2288	7,4805
4,5461	0,2728	9,6326	0,1605	<b>1,000</b>	1,2009
3,7854	0,2271	8,0208	0,1337	0,8327	<b>1,000</b>

## PRESSURE AND HEAD

Newton per square metre N/m <sup>2</sup>	kilo Pascal kPa	bar bar	Pound force per square inch psi	Metre of water m H <sub>2</sub> O	Millimetre of mercury mm Hg
<b>1,000</b>	0,0010	1 x 10 <sup>-5</sup>	1,45 x 10 <sup>-4</sup>	1,02 x 10 <sup>-4</sup>	0,0075
1 000,0000	<b>1,000</b>	0,0100	0,1450	0,1020	7,5006
1 x 10 <sup>5</sup>	100,0000	<b>1,000</b>	14,5038	10,1972	750,0638
6 894,7570	6,8948	0,0689	<b>1,000</b>	0,7031	51,7151
9 806,6500	9,8067	0,0981	1,4223	<b>1,000</b>	73,5561
133,3220	0,1333	0,0013	0,0193	0,0136	<b>1,000</b>

## LENGTH

Millimetre mm	Centimetre cm	Metre m	Inch in	Foot ft	Yard yd
<b>1,000</b>	0,1000	0,0010	0,0394	0,0033	0,0011
10,0000	<b>1,000</b>	0,0100	0,3937	0,0328	0,0109
1 000,0000	100,0000	<b>1,000</b>	39,3701	3,2808	1,0936
25,4000	2,5400	0,0254	<b>1,000</b>	0,0833	0,0278
304,8000	30,4800	0,3048	12,0000	<b>1,000</b>	0,3333
914,4000	91,4400	0,9144	36,0000	3,0000	<b>1,000</b>

## VOLUME

Cubic metre m <sup>3</sup>	Litre L	Millilitre ml	Imperial gallon imp. gal.	U.S. gallon US gal.	Cubic foot ft <sup>3</sup>
<b>1,000</b>	1 000,0000	1 x 10 <sup>6</sup>	219,9694	264,1720	35,3147
0,0010	<b>1,000</b>	1 000,0000	0,2200	0,2642	0,0353
1 x 10 <sup>-6</sup>	0,0010	<b>1,000</b>	2,2 x 10 <sup>-4</sup>	2,642 x 10 <sup>-4</sup>	3,53 x 10 <sup>-5</sup>
0,0045	4,5461	4 546,0870	<b>1,000</b>	1,2009	0,1605
0,0038	3,7854	3 785,4120	0,8327	<b>1,000</b>	0,1337
0,0283	28,3168	28 316,8466	6,2288	7,4805	<b>1,000</b>

## TEMPERATURE

Water	Kelvin K	Celsius °C	Fahrenheit °F	$^{\circ}\text{F} = ^{\circ}\text{C} \times \frac{9}{5} + 32$ $^{\circ}\text{C} = (^{\circ}\text{F} - 32) \times \frac{5}{9}$
icing	273,1500	0,0000	32,0000	
boiling	373,1500	100,0000	212,0000	

G-at\_pp-en\_b\_sc

**FURTHER PRODUCT SELECTION  
AND DOCUMENTATION**  
**Xylect**

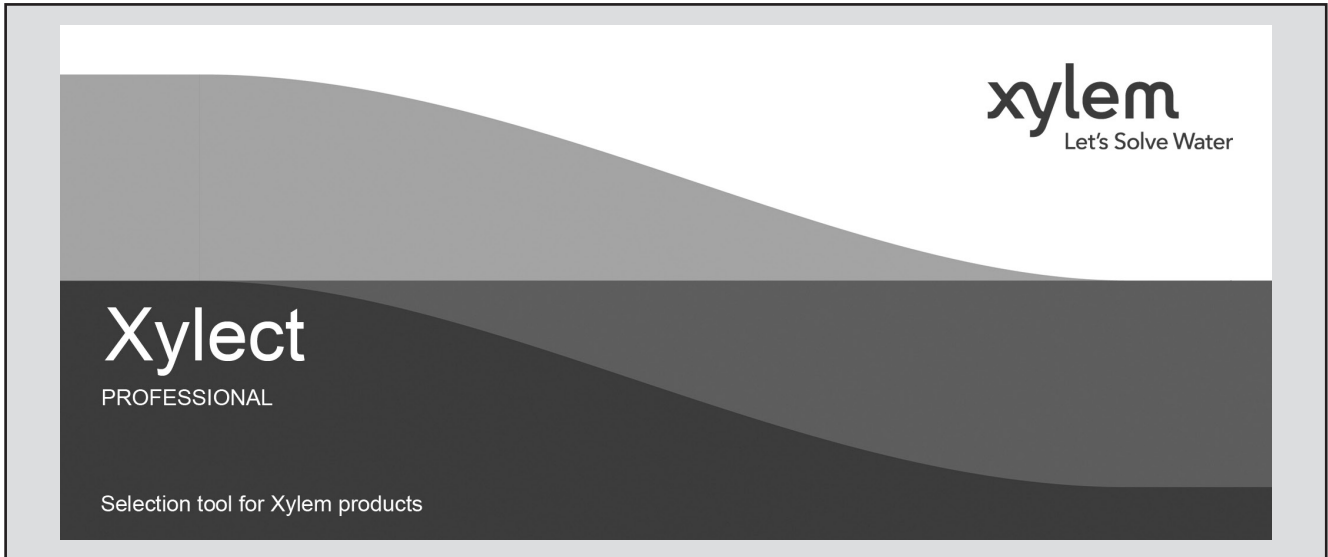

Xylect is pump solution selection software with an extensive online database of product information across the entire Lowara range of pumps and related products, with multiple search options and helpful project management facilities. The system holds up-to-date product information on thousands of products and accessories.

The possibility to search by applications and the detailed information output given makes it easy to make the optimal selection without having detailed knowledge about the Lowara products.

The search can be made by:

- Application
- Product type
- Duty point

Xylect gives a detailed output:

- List with search results
- Performance curves (flow, head, power, efficiency, NPSH)
- Motor data
- Dimensional drawings
- Options
- Data sheet printouts
- Document downloads incl dxf files

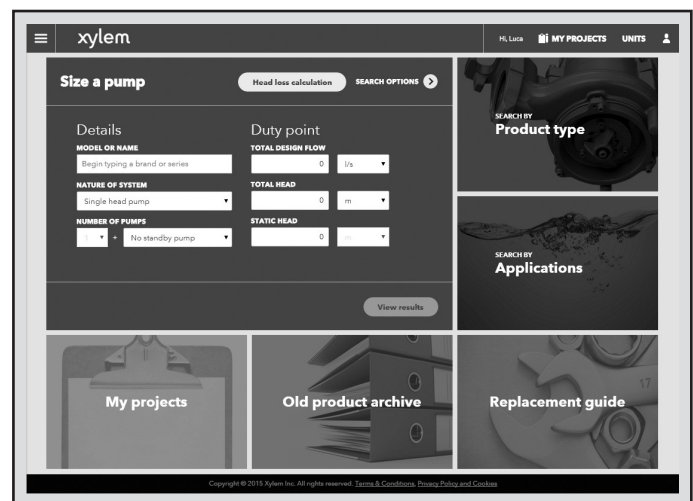

*The search by application guides users not familiar with the product range to the right choice.*

## FURTHER PRODUCT SELECTION AND DOCUMENTATION

### Xylect



The detailed output makes it easy to select the optimal pump from the given alternatives.

The best way to work with Xylect is to create a personal account. This makes it possible to:

- Set own standard units
- Create and save projects
- Share projects with other Xylect users

Every registered user has a proper space, where all projects are saved.

For more information about Xylect please contact our sales network or visit [www.xylect.com](http://www.xylect.com).

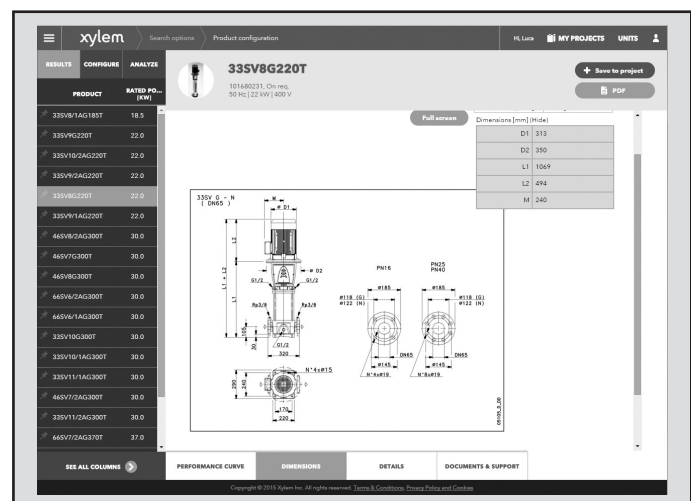

Dimensional drawings appear on the screen and can be downloaded in dxf format.





# Xylem |'zīləm|

- 1) The tissue in plants that brings water upward from the roots;
- 2) a leading global water technology company.

We're a global team unified in a common purpose: creating advanced technology solutions to the world's water challenges. Developing new technologies that will improve the way water is used, conserved, and re-used in the future is central to our work. Our products and services move, treat, analyze, monitor and return water to the environment, in public utility, industrial, residential and commercial building services settings. Xylem also provides a leading portfolio of smart metering, network technologies and advanced analytics solutions for water, electric and gas utilities. In more than 150 countries, we have strong, long-standing relationships with customers who know us for our powerful combination of leading product brands and applications expertise with a strong focus on developing comprehensive, sustainable solutions.

**For more information on how Xylem can help you, go to [www.xylem.com](http://www.xylem.com).**



Legal head office  
Xylem Water Solutions Italia Srl

Via Gioacchino Rossini 1/A  
20020 - Lainate (MI) - Italy  
Tel. (+39) 02 90358.1  
Fax (+39) 02 9019990  
[www.xylemwatersolutions.com](http://www.xylemwatersolutions.com)

For information and technical support  
Xylem Service Italia Srl

Via Dottor Vittorio Lombardi 14  
36075 - Montecchio Maggiore (VI) - Italy  
Tel. (+39) 0444 707111  
Fax (+39) 0444 491043  
[www.lowara.com](http://www.lowara.com)

Xylem Water Solutions Italia Srl reserves the right to make modification without prior notice.  
Lowara, Xylem are trademarks of Xylem Inc. or one of its subsidiaries  
© 2019 Xylem, Inc.