

MANUAL

Enmix Basic

Low-speed agitator mixer



Version: 2025-10

FOREWORD

This installation manual is intended for technicians who assemble, install, maintain and use the Enmix Basic agitator mixer, hereafter referred to as the Enmix.

This installation manual contains instructions relating to the safe assembly, installation and operation of the Enmix. This manual is not applicable to the whole system; a manual for this must be provided by the installer.

Each chapter is numbered and, where necessary, the chapters are divided into sections. The table of contents on page 3 gives an overview of the chapters and sections and a reference to the page numbers. In the text, when a number is shown in brackets after a part, this refers to the part number in the overview drawing on page 5.

TABLE OF CONTENTS

- Foreword2
- Table of Contents3
- 1 Identification4
 - 1.1 General4
 - 1.1.1 Description of the system/machine4
 - 1.1.2 Specifications4
 - 1.1.3 Schematic diagram of the Enmix5
 - 1.1.4 Schematic diagram of the delivered packages6
 - 1.2 Use7
 - 1.3 Users7
 - 1.4 Media7
 - 1.5 Operating environment7
 - 1.6 Guarantee conditions7
 - 1.7 CE and UKCA mark7
 - 1.8 Residual risks7
- 2 Description8
 - 2.1 General8
 - 2.2 Working principle8
 - 2.3 Transport and storage8
- 3 Safety instructions9
- 4 Assembly and installation10
 - 4.1 General10
 - 4.2 Installation instructions10
 - 4.3 Delivery checklist10
 - 4.4 Assembly10
 - 4.4.1 Measuring the liquid tank10
 - 4.4.2 Assembling the frame11
 - 4.4.3 Assembling the shaft guide (only required for shaft length >1m)12
 - 4.4.4 Assembling the motor with reduction gearbox and mixer shaft13
 - 4.4.5 Assembling the mixer blade14
 - 4.5 Installation15
 - 4.6 Electrical connection15
 - 4.7 Start-up15
- 5 Start-up16
- 6 Maintenance17
 - 6.1 Regular checks17
 - 6.2 Maintenance report17
- 7 Faults18
- 8 CE Declaration of Conformity19
- 9 UKCA Declaration of Conformity20
- Annexes21
 - List of parts22
 - Exploded view23
 - Overview of dimensions24
 - Reduction gearbox oil25

1 IDENTIFICATION

This chapter contains general information about the Enmix. The purpose of this chapter is to indicate the limits and overall operation of the Enmix, and the areas in which it is used.

1.1 General

The low-speed Enmix Basic is the ideal solution for mixing liquids and keeping them in motion in fertiliser tanks or tanks for other mixed liquids. The Enmix can also be used for mixing solid fertilisers, for example from big bags. In modern greenhouse horticulture, the ever-increasing size of mixing tanks can create problems when solid fertilisers need to be properly dissolved in the water. The Enmix agitator mixer is the most optimal solution for this.

1.1.1 Description of the system/machine

The Enmix consists of a frame, a motor with reduction gearbox and a shaft with mixer blade made of 304 stainless steel. The frame and mixer are available in various types – short/long frame, short/long mixer shaft and 50/60Hz – and they can be adjusted to fit the dimensions of the liquid tank, up to a maximum width of 246cm and depth of 150cm. The mixer blade has a turn diameter of 75/100cm, rotating slowly and ensuring that all the contents of the tank, up to a maximum volume of 10m³, are kept sufficiently in motion. The Enmix Basic is delivered as a flatpack and can be assembled, mounted and installed on-site by the installer.

1.1.2 Specifications

General						
Type	Enmix Basic					
Maximum dimensions [LxWxH]	2510 x 1000 x 1660mm (assembled)					
Total weight (max.)	40 kg					
Ingress protection rating (dust and water)	IP55					
Electricity connection	See table for motor with reduction gearbox					
Material	304 stainless steel					
Motor with reduction gearbox						
Power	0.37 kW					
Transmission ratio	15:1					
Ingress protection rating (dust and water)	IP55					
Capacitor*	12,5 or 20 µF					
*Only applied to 1 phase 230V when replacing capacitor check the value						
Possible motors	Frequency	Voltage	Current	Speed	Phases	Weight
	50 Hz**	230 V	2.00 A	1370 rpm	1 phase	6.2 kg
	50 Hz**	400 V	1.15 A	1410 rpm	3 phase	5.4 kg
	60 Hz***	440-480 V	1.15 A	1680 rpm	3 phase	5.4 kg
	60 Hz***	480 V	0.91 A	1715 rpm	3 phase	9.5 kg
	60 Hz***	575-600 V	0.70 A	1680 rpm	3 phase	8.0 kg
	**Deliver with 100cm mixer blade					
	***Deliver with 75 cm mixer blade					
	Other frequencies and voltages available on request					
Mixer						
Speed	94 rpm (50 Hz variant)					
	112 rpm (60 Hz variant)					
Frame						
Frame	stainless steel 304					
Mixer shaft	stainless steel 304					
Mixer blade	stainless steel 304					
Motor with reduction gearbox	Aluminium/steel					

Table 1 Specifications of the Enmix Basic

1.1.3 Schematic diagram of the Enmix

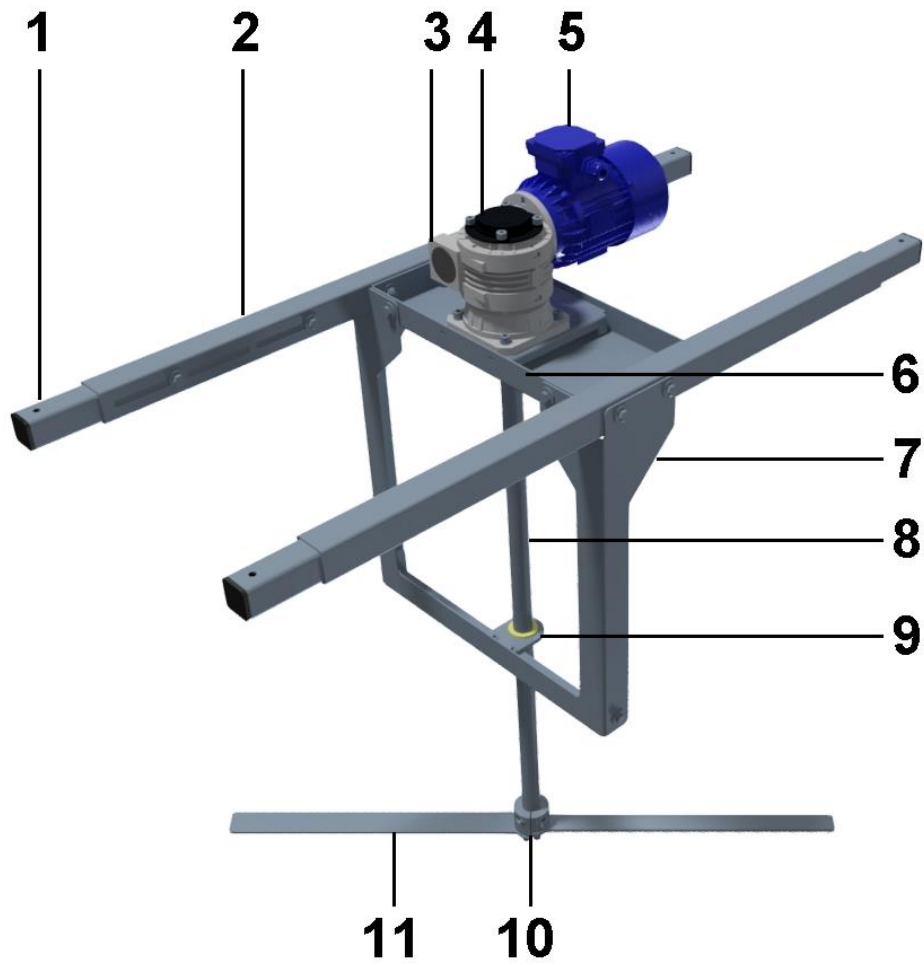

Figure 1 Parts of the Enmix Basic

No.	Name
1	Frame extension: short/long
2	Basic frame
3	Reduction gearbox 15:1
4	Cover of reduction gearbox
5	Electric motor
6	Motor mounting tray
7	Shaft guide
8	Mixer shaft
9	Plate bush + slide bearing
10	Mixer blade connector
11	Mixer blade

Table 2 Parts of the Enmix Basic

1.1.4 Schematic diagram of the delivered packages

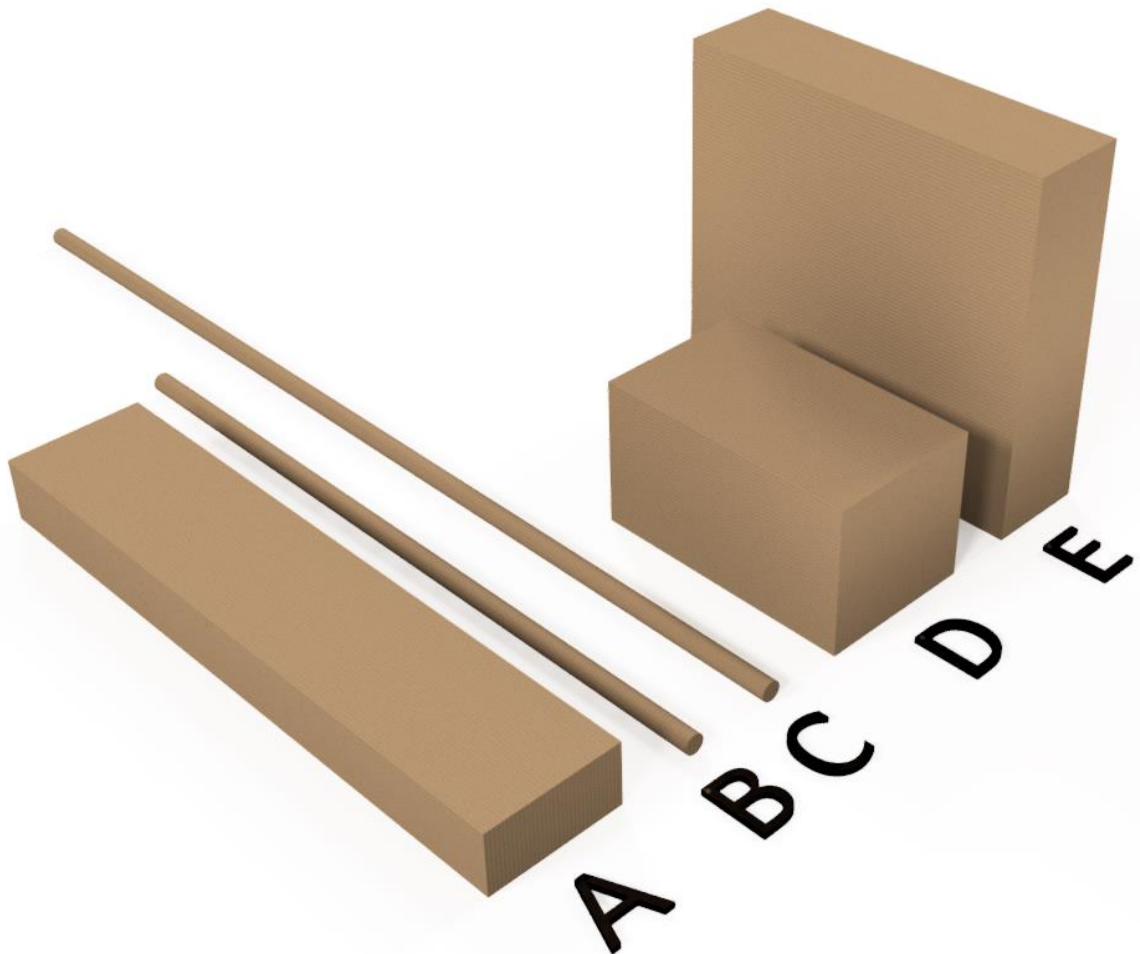

Figure 2 Packages containing the Enmix Basic

Letter	Name
A	Enmix frame: short/long
B	Mixer shaft: short (liquid tanks <1m depth)
C	Mixer shaft: long (liquid tanks <1.5m depth)
D	Motor with reduction gearbox
E	Shaft guide (required for long mixer shaft (C))

See Annex 0 for the precise content of the packages.

Table 3 Packages containing the Enmix Basic

1.2 Use

The Enmix is intended to be used for mixing liquids or fertilisers, and keeping them in motion, in appropriate mixing tanks or liquid tanks. To achieve this, the Enmix must be placed above the liquid tank, with the mixing blade (11) in the liquid.

1.3 Users

Operators and users of the Enmix must be at least 18 years of age, employed by the relevant organisation and designated by the management as competent and authorised to operate or maintain the Enmix. All users who do not meet the above definition are unintended users, who may create unsafe situations or cause danger to themselves and/or others by using the Enmix.

1.4 Media

Placement in media of an image or comment relating to the Enmix must always be discussed in advance with the manufacturer or supplier. If this is not done, any consequential damage may be recovered from this person or company.

1.5 Operating environment

The Enmix must be installed on an appropriate (rigid) liquid tank. There must be sufficient space around the liquid tank to allow installation and maintenance activities to be performed. The recommended ambient temperature is between 0 °C and 50 °C.

1.6 Guarantee conditions

The Enmix is guaranteed for a period of 6 months from the date of purchase.

If a claim is made under the guarantee, the relevant parts or the whole Enmix must be presented to the manufacturer for assessment.

The guarantee is void if one or more of the following conditions apply:

- Improper use;
- Repeatedly ignoring the manufacturer's and/or supplier's advice;
- Repair, maintenance or use by unauthorised persons;
- Use of the machine in an unsuitable environment;
- Intentional damage or modification of the machine.

1.7 CE and UKCA mark

The Enmix Basic complies with the provisions of the following directives:

- Machinery Directive 2006/42/EC
- Low Voltage Directive 2006/95/EC (Class 1)
- EMC Directive 97-23-EC
- Supply of Machinery (Safety) Regulations 2008:1597
- Electrical Equipment (Safety) Regulations 2016:1101
- Electro Magnetic Compatibility Regulations 2016:1091

1.8 Residual risks

Operators and users are expected to comply with all the points specified above; in situations that have not been described, they should always inform the manufacturer or supplier. External connections, such as the power supply cable, fall under the responsibility of the installer or user, and Van der Ende Groep is not liable for them. Table 4 describes the residual risks that were identified in the risk analysis for CE certification.

<i>Risk no.:</i>	<i>Description</i>	<i>Risk</i>	<i>Risk class</i>
1	The machine includes unprotected rotating parts.	3	A
2	There is a chance that a defect could cause the Enmix Basic to become electrically 'live'.	3	A

Table 4 Residual risks identified in the risk analysis

2 DESCRIPTION

This chapter describes how the Enmix should be used and the applications for which it is suitable. The general description and outline of the working principle offer an understanding of the intended purpose of this machine.

2.1 General

The purpose of the Enmix Basic is the compact and efficient supply of a complete agitator mixer. There are two different models of the Enmix Basic, which are suitable for liquid tanks with a width of 1100 to 2500mm and a depth of 180 to 1500mm, up to a maximum volume of 10m³.

The Enmix is suitable for mixing liquids containing fibres up to a maximum length of 5mm, with a viscosity of <1000mPas and a minimum pH of 4.

The Enmix is delivered as a flatpack and must be assembled on-site by the installer. All the necessary materials are supplied, including tools and gloves. However, the attachment materials for mounting the Enmix on the mixing tank are not included. Chapter 4 of this manual gives a step-by-step description of how to assemble the Enmix.

Annex 0 shows which Enmix model must be used for the correct dimensions of the liquid tank.

2.2 Working principle

The Enmix is designed for mixing liquids and/or keeping them in motion in fertiliser tanks or tanks for other liquids. The Enmix can also be used for solid fertilisers, for example from big bags.

The mixer blade rotates slowly (94 rpm in the 50Hz variant, 112 rpm in the 60Hz variant), which ensures that no foaming occurs in the liquid tank. If the Enmix will be used in a round tank, we advise that two vertical strips are fitted inside the tank, to prevent a vortex or swirling motion of the entire contents. These strips serve as anti-vortex baffles around the shaft and ensure correct mixing within the tank.

2.3 Transport and storage

The Enmix is delivered in several packages; see section 1.1.4 for a detailed explanation. Both the transport and storage require a clean, dry environment with a minimum ambient temperature of 0°C. All the packages must be handled with great care, especially the package containing the mixer shaft, since damage to the mixer shaft can have serious adverse consequences for the entire Enmix agitator mixer.





3 SAFETY INSTRUCTIONS

The installer must ensure at all times that the Enmix is correctly assembled and installed; in case of doubt, the manufacturer or supplier must be contacted.

During maintenance on the Enmix, the power supply cable of the motor with reduction gearbox must be interrupted and made safe. This will prevent electrocution and will ensure that the Enmix does not suddenly start to operate.

If activities in the form of mechanical or electrical modifications are planned, it is essential to inform the manufacturer or supplier in advance, so that possible hazards can be prevented.

The following safety instructions are applicable to the Enmix Basic.

Safety symbol	Meaning
	Machine starts automatically!
	High voltage!
	Hot surface!
	Rotating parts!
	Refer to manual!

4 ASSEMBLY AND INSTALLATION

This chapter describes how the Enmix must be assembled and installed. You must read the entire manual carefully before starting on the assembly and installation. We recommend that the assembly and installation are carried out by two people.

4.1 General

The Enmix agitator mixer and mounting frame are made entirely of stainless steel and are delivered as a flatpack, in accordance with the dimensions of the liquid tank. The mixer blade has a turn diameter of 100cm (or 75cm in the 60Hz variant); it rotates slowly and ensures that all the contents of the tank, up to a maximum volume of 10m³, are kept sufficiently in motion.

The Enmix is delivered in three packages: the electric motor with reduction gearbox, the frame and the mixer shaft. For tanks with a depth >100cm, there is also an additional package: a shaft guide, which is easy to fasten to the frame and gives extra support for the mixer shaft.

PLEASE NOTE: The Enmix mixer blade must be screened in some way to ensure that users do not come into contact with it; for this, you should use a cover and grille or other adequate protective device.

4.2 Installation instructions

After the Enmix has been fully assembled, it can be installed on the liquid tank. You are strongly advised to take the following points into account during the installation:

- The Enmix frame must be attached to the liquid tank with four m8 bolts, locknuts and washers (not supplied).
- The cooling fan cover of the electric motor must not be impeded by any obstacles; the motor must be able to intake enough air.
- The electric motor must be connected to the electricity network in conformity with NEN-1010.
- The electric motor must be earthed at all times, to prevent electrocution.

4.3 Delivery checklist

Before starting to assemble the Enmix, make sure that all parts are present. Annex 0 provides an overview of the parts that the various packages contain.

4.4 Assembly

This section gives a step-by-step description of how to assemble the Enmix. Follow all these steps carefully, to prevent problems later.

PLEASE NOTE: When attaching all the separate bolts, you should lubricate them in advance with the supplied bolt grease; a small quantity at the end of the thread is sufficient. This will ensure that the stainless steel does not become 'galled' and can no longer be removed.

To prevent possible hand injury, one pair of gloves is supplied; these are in the package containing the frame (A).

4.4.1 Measuring the liquid tank

1. Measure the width and depth of the liquid tank;
2. In Annex 0, fill in the centre-to-centre distance and tank depth;
3. Check that you have the correct frame and mixer shaft (short/long).

4.4.2 Assembling the frame

PLEASE NOTE: When attaching all the separate bolts, you should lubricate them in advance with the supplied bolt grease; a small quantity at the end of the thread is sufficient. This will ensure that the stainless steel does not become 'galled' and can no longer be removed.

1. Open the package containing the frame (A); take all the parts out of the package and arrange them clearly and carefully.
PLEASE NOTE: Inside each of the basic frame parts (2) there is one frame extension (1); also take this extension out of the basic frame.
2. Place the motor mounting tray (6) on a flat surface.
3. Place the basic frame parts (2) next to this, with the slots facing inwards.
4. Attach the basic frame parts (2) to the motor mounting tray (6) using the following parts. If a shaft guide (7) will be used, the bolts should only be hand-tightened at this stage. Ensure that the nuts are attached at the motor mounting tray (6) side.
 - 4x bolt m8x65
 - 8x fender washer m8
 - 4x locknut m8
5. Place the frame extensions (1) in the basic frame (2); the tapped holes must face inwards and the black caps must extend out of the basic frame.
6. Ensure that the attachment holes of the frame extensions (1) are adjusted to the correct centre-to-centre distance of the liquid tank.
7. Attach the frame extensions (1) to the basic frame (2) using the following parts:
 - 8x bolt m8x12
 - 8x fender washer m8
8. For extra information about the assembly, see Figure 3.

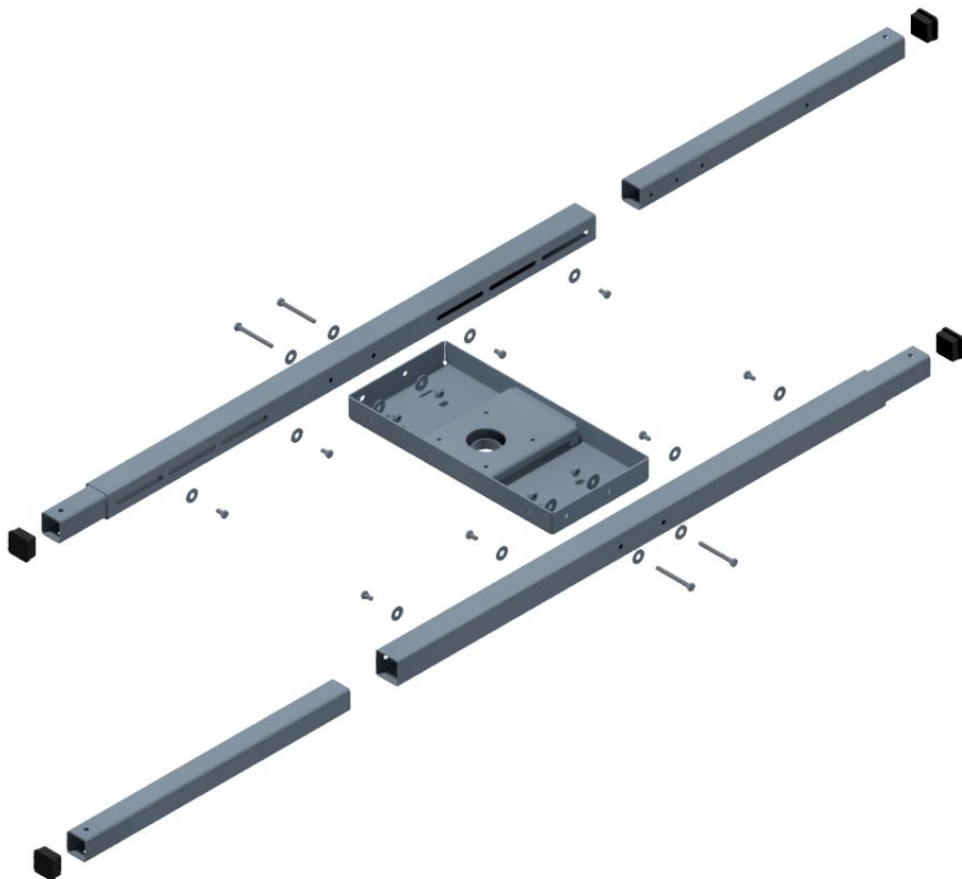

Figure 3 Basic frame of the Enmix Basic

4.4.3 Assembling the shaft guide (only required for shaft length >1m)

1. Open the package containing the shaft guide (E); take all the parts out of the package and arrange them clearly and carefully.
2. Remove the four locknuts attaching the basic frame (2) to the motor mounting tray (6); leave the bolts in the frame.
3. Place the frame upside down, ensuring that the bolts stay in the frame.
4. Now take out the bolts attaching the basic frame (2) to the motor mounting tray (6), ensuring that the parts remain positioned in such a way that the bolts can easily be re-inserted.
5. Now place the shaft guide (7) on the frame correctly and re-insert the bolts that you just took out.
6. Attach the shaft guide (7) to the front of the motor mounting tray (6) using the following parts. Insert the following bolts from the shaft guide (7) side.
 - 2x bolt m8x10
 - 2x fender washer m8
7. Attach the two bolts to the corners of the shaft guide (7) using the following parts. Insert the following bolts from the outside of the shaft guide (7).
 - 2x bolt m8x10
 - 2x fender washer m8
8. Attach the plate bush + slide bearing (9) to the shaft guide (7) using the following parts. Ensure that it is attached correctly; see Figure 4.
 - 2x bolt m8x25
 - 4x fender washer m8
 - 2x locknut m8
9. Tilt the frame back again, so that it is resting on the shaft guide (7) and one side of the frame.
10. Firmly tighten the four locknuts that hold together the shaft guide, the basic frame and motor mounting tray.
11. The frame will now look as shown in Figure 4.



Figure 4 Frame including the shaft guide

4.4.4 Assembling the motor with reduction gearbox and mixer shaft

1. Open the packages containing the motor with reduction gearbox (D) and the mixer shaft (B or C); take all the parts out of the packages and arrange them clearly and carefully.
2. Remove the cover (4) by taking out the four hollow-head screws.
3. Place the NBR rubber washer over the mixer shaft (8), at the keyway side, and ensure that it is located at approximately 4cm on the thicker section of the shaft.
4. Remove the following parts at the top of the mixer shaft and arrange them clearly and carefully.
 - 1x bolt m10x20
 - 1x spring washer m10
 - 1x fender washer m10
5. Remove the protective sleeve covering the sunk key.
6. Place the motor with reduction gearbox (5) on its side on a soft surface and slide the mixer shaft into the reduction gearbox.
PLEASE NOTE: Ensure that the sunk key is in place in the mixer shaft.
7. Re-attach the parts listed in step 4 to the top of the mixer shaft, making sure that they are firmly tightened; this will ensure that the mixer shaft (8) cannot fall out of the reduction gearbox (3).
8. Place the frame on its side, so that you can slide the mixer shaft into the frame via the top of the motor mounting tray (6).
9. Attach the reduction gearbox (3) to the motor mounting tray (6) with the following parts, making sure that the motor with reduction gearbox is positioned correctly; see Figure 5.
 - 4x hollow-head screw m8x20
 - 4x spring washer m8
10. Put the cover (4) back onto the reduction gearbox (3) using the four hollow-head screws.
11. The Enmix will now look as shown in Figure 5.

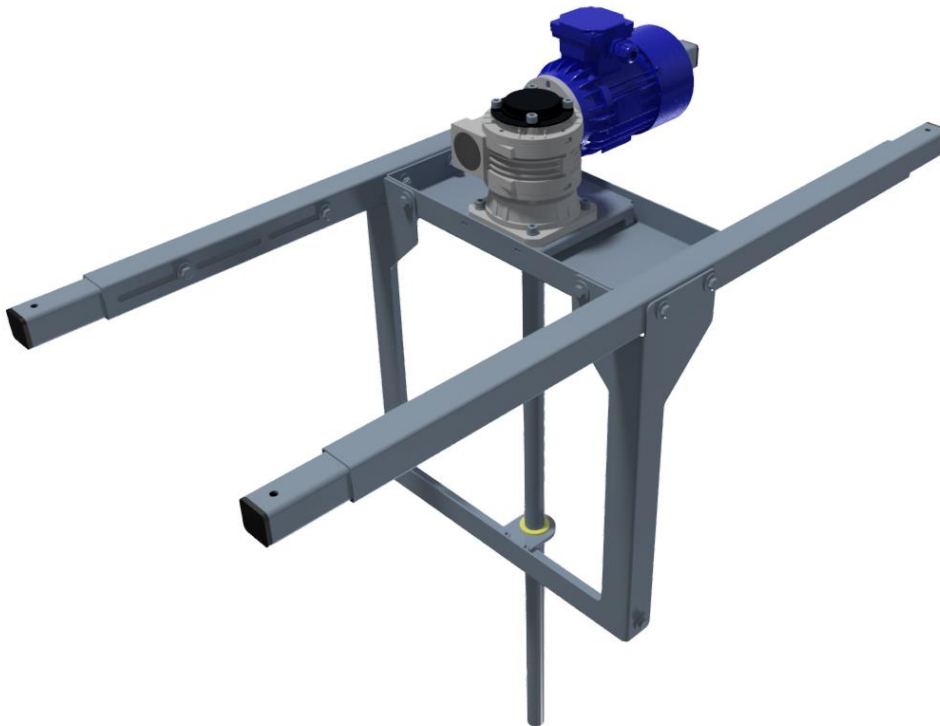

Figure 5 Enmix excluding the mixer blade

4.4.5 Assembling the mixer blade

1. Place the mixer blade connector (10) on the mixer shaft (8), ensuring that the slanted side faces downward; slide the mixer blade connector (10) to the correct height:
 - Depth of liquid tank – 80mm = height of the underside of the mixer blade connector (10) to the underside of the basic frame (2).
2. Attach the mixer blade connector (10) by screwing the two hollow-head screws + 2 spring washers into the sides of the mixer blade connector (10).
3. Attach the two halves of the mixer blade (11) to the mixer blade connector (10) using the following parts.
 - 6x hollow-head screw m8x20
 - 6x spring washer m8
4. The mixer shaft (8) that extends below the mixer blade connector (10) can be cut off with an angle grinder; ensure that the mixer blade connector (10) is attached at the correct height and support the mixer shaft (8) while cutting it, to prevent the mixer shaft (8) becoming bent.
5. The Enmix is now completely assembled (see Figure 6), and ready to be installed.



Figure 6 The complete Enmix Basic

4.5 Installation

After you have assembled the Enmix by following the steps in section 4.4, it can now be installed.

Installing the Enmix is fairly simple, but we advise that these activities are performed by two people, in view of the combination of the dimensions and weight.

Before placing the Enmix on the liquid tank, check that the centre-to-centre distance of the frame corresponds with the dimensions of the liquid tank. After you have checked this, the Enmix can be lifted or hoisted onto the liquid tank. Make sure that both sides of the frame are resting on the side of the tank, and check that the mixer blade (11) is suspended approximately 80mm above the bottom of the tank. You can now drill the holes in the liquid tank, using an 8mm drill bit, through the extensions (1) of the frame. After drilling the holes, we recommend that you immediately attach the extension (1) to the liquid tank with the supplied m8 bolts, nuts and washers. If you wish, you can cut them to size in advance.

When all four of the extensions (1) of the Enmix frame have been attached to the liquid tank, you must check that the mixer blade (11) can rotate freely in the tank. You can check this by manually rotating the mixer shaft (8).

4.6 Electrical connection

The Enmix must be electrically connected in conformity with NEN-1010. Table 5 shows the specifications of the various motors with reduction gearbox.

Data of motors with reduction gearbox								
Frequency	Voltage	Power	Current	Speed	Phases	Cos φ	Weight	Quality mark
50 Hz	230 V	0,37 kW	2.0 A	1370	1 phase	0.96	6.2 kg	CE
50 Hz	400 V	0,37 kW	1.2 A	1410	3 phase	0.69	5.4 kg	CE
60 Hz	440 – 480 V	0,37 kW	1.2 A	1680	3 phase	0.69	5.4 kg	CE
60 Hz	480 V	0,37 kW	0.9 A	1715	3 phase	0.67	9.5 kg	cURus
60 Hz	575 – 600 V*	0,37 kW	0.7 A	1680	3 phase	0.72	8.0 kg	cURus
Other frequencies and voltages are available on request.								

Table 5 Data of motors with reduction gearbox

*The 575V variant of the motor with reduction gearbox is optionally available with a 1.5m cable. If this is used, it must be connected as described below.

PLEASE NOTE: Make sure that there is no voltage present at the terminal connectors when connecting the cable!

- L1 = U1
- L2 = V1
- L3 = W1
- L4+L5 = thermostatic switch

The certifications of the motors with reduction gearbox can be provided on request.

4.7 Start-up

After the Enmix has been completely assembled, installed and electrically connected, you can start it up. Chapter 5 describes how the start-up of the Enmix must be performed.

PLEASE NOTE: To ensure a longer service life, we recommend that the motor with reduction gearbox should not be started/stopped more than 20x per hour.

5 START-UP

Start-up of the Enmix must be performed in accordance with the following steps. You must ensure that the system complies with the installation requirements specified in Chapter 4.

Step-by-step start-up of the Enmix	
Step	Action
1	Make sure that the Enmix has been correctly assembled and securely attached to the liquid tank.
2	Make sure that the mixer blade (11) can rotate freely in the liquid tank; you can check this by manually rotating the mixer shaft (8).
3	Make sure that the power supply cable is correctly connected.
4	Make sure that the liquid tank is empty before starting the Enmix. You must also check that the mixer blade (11) is rotating in the correct direction (clockwise) and that the mixer shaft (8) is not oscillating.
5	Switch off the Enmix before filling the liquid tank. We recommend that you fit a low-water float in the liquid tank; this will automatically switch off the Enmix if the liquid level is too low.
6	Once the liquid tank has been filled, you can start the Enmix. Check that it is keeping the liquid effectively in motion.
7	After making sure that all the above points are in order, the Enmix can remain in operation and, if applicable, fertilisers can gradually be added to the liquid.

6 MAINTENANCE

This chapter specifies the maintenance intervals. When performing any maintenance other than visual checking, you must always disconnect the entire system from the power supply.

6.1 Regular checks

The Enmix is practically maintenance-free. We recommend that you visually check the Enmix during operation once per month, to make sure that it is correct and working properly, and that you service the Enmix once per quarter. The checklist below explains the activities in more detail. We recommend that you replace the oil in the reduction gearbox (3) every five years; see Table 6 and Annex 0 for details of the appropriate oil.

Reduction gearbox oil		
Shell Cassida Fluid	GL 460 NON TOX	VDEG Part No. : 97003470

Table 6 Specifications of the reduction gearbox oil

Frequency: per quarter

- Check that the frame extensions (1) are still securely attached to the liquid tank;
- Check that all parts of the Enmix are still firmly held together.
 - Check the four hollow-head screws used for attaching the reduction gearbox (3).
 - Check all the bolts used for holding the frame together.
 - Check the bolts used for attaching the shaft guide (9).
- Check that the bolt of the mixer shaft (8) is still tight.
 - Remove the cover (4) (four hollow-head screws) of the reduction gearbox (3).
 - Check the m10 bolt; if necessary, tighten it again.
 - Put the cover (4) back onto the reduction gearbox (3).
- Check that the mixer blade (11) can still rotate freely; you can check this by manually rotating the mixer shaft (8).
- Check that the mixer shaft (8) is still straight.
- Check that the motor with reduction gearbox (5) and motor mounting tray (6) are still free of oil.
 - If this is not the case, you should check the Enmix more frequently. If this oil continues to leak, you must contact the manufacturer or supplier.

6.2 Maintenance report

After every service, as described in section 6.1, you must write down the activities performed on the last page of this manual.

Fill in 'frequent maintenance' when no extra activities were performed. If defects were observed or repaired during the maintenance, this must always be included in the report.

7 FAULTS

This chapter describes possible faults, together with causes and solutions. While working on the Enmix, you must comply with the instructions in all the chapters of this manual, in order to prevent unsafe situations.

Fault	Cause	Solution
The motor with reduction gearbox (5) is no longer working	No power supply	Check the power supply
	Thermal protection has cut out	Remove any large solid particles from the liquid tank and reset the thermal protection
	Capacitor is defective (only 1 fase 230V variant)	Replace the capacitor
The thermal protection cuts out frequently	Too many large solid particles (>5mm) in the liquid tank	Remove the large solid particles from the liquid tank and reset the thermal protection
	Too high viscosity (>1000mPas) of liquid in the tank	Dilute the liquid or remove it from the tank
	Mixer shaft (8) is bent	Contact the supplier or manufacturer
	Guide bush (9) is dirty	Take the mixer shaft (8) out of the guide bush (9) and clean the guide bush. For this, consult Chapter 4 of the manual
The motor with reduction gearbox (5) is working but the mixer shaft (8) is not rotating	Reduction gearbox (3) is defective	Contact the supplier or manufacturer
The motor with reduction gearbox (5) is working and the mixer shaft (8) is rotating, but the liquid is not set in motion	Mixer blade connector (10) is slipping on the mixer shaft (8)	Check the mixer blade connector (10)
There is oil in the motor mounting tray (6)	There is too much oil in the reduction gearbox (3)	If there is too much oil in the reduction gearbox (3), during operation the excess oil is forced out of the reduction gearbox (3). If the quantity of oil is very small, no action needs to be taken.
	Reduction gearbox (3) is defective	Contact the supplier or manufacturer

8 CE DECLARATION OF CONFORMITY

EC DECLARATION OF CONFORMITY

(in accordance with Annex II A of the Machinery Directive 2006/42/EC)

We, Van der Ende Pompen
Aartsdijkweg 23
2676 LE Maasdijk
Netherlands

Hereby declare under our sole responsibility that the machine:

Enmix Basic

To which this Declaration relates, is in conformity with the provisions of the following Directives:

Machinery Directive	2006/42/EC
Low Voltage Directive	2006/95/EC
EMC Directive	97-23-EC

And (where applicable) is in conformity with the following standards or other normative documents:

not applicable

Netherlands
Maasdijk
1 February 2022

L. van der Ende



9 UKCA DECLARATION OF CONFORMITY

UKCA DECLARATION OF CONFORMITY

We, Van der Ende Pompen
Aartsdijkweg 23
2676 LE Maasdijk
Netherlands

Hereby declare under our sole responsibility that the machine:

Enmix Basic

To which this Declaration relates, is in conformity with the provisions of the following Directives and their admendments;

Supply of Machinery (Safety) Regulations	2008:1597
Electrical Equipment (Safety) Regulations	2016:1101
Electro Magnetic Compatibility Regulations	2016:1091

And (where applicable) is in conformity with the following standards or other normative documents:

not applicable

Netherlands
Maasdijk
13 December 2022

L. van der Ende



ANNEXES

- List of parts
- Exploded view
- Overview of dimensions
- Reduction gearbox oil

List of parts

Package: Enmix frame: short/long (A)		
Quantity	Description	VDEG Part No.
1	Stainless steel motor mounting tray (6)	55022620
2	Stainless steel basic frame (2)	55022780
4	Stainless steel frame extension short/long (1)	55022790 55022800
1	Stainless steel mixer blade connector (10)	55022700
2	Stainless steel mixer blade 50Hz (11) Stainless steel mixer blade 60Hz (11)	55022750 55022760
4	PE insert cap 40x40x3mm (inserted in the frame extension)	75141150
8	Stainless steel hexagon tap bolt m8x12	57005910
4	Stainless steel hexagon tap bolt m8x65	57006020
12	Stainless steel hollow-head hexagon bolt m8x20	57009030
4	Stainless steel self-locking nut m8	57004140
16	Stainless steel fender washer m8	57000140
12	Stainless steel spring washer m8	57002140
1	Pair of work gloves	97011372
1	Hex key 6mm	97020680
2	Double-head wrench 13x17mm	97021340
1	Pot of bolt grease	55025100
Package: Mixer shaft: short (B)		
Quantity	Description	VDEG Part No.
1	Stainless steel mixer shaft 1100mm (8)	55022710
1	Stainless steel sunk key 8x7x40mm	56035100
1	Rubber shaft sleeve 25mm	20020900
1	NBR rubber washer 30x50x3mm	50708120
1	Stainless steel hexagon tap bolt m10x20	57006220
1	Stainless steel fender washer m10	57000150
1	Stainless steel spring washer m10	57002150
Package: Mixer shaft: long (C)		
Quantity	Description	VDEG Part No.
1	Stainless steel mixer shaft 1600mm (8)	55022720
1	Stainless steel sunk key 8x7x40mm	56035100
1	Rubber shaft sleeve 25mm	20020900
1	NBR rubber washer 30x50x3mm	50708120
1	Stainless steel hexagon tap bolt m10x20	57006220
1	Stainless steel fender washer m10	57000150
1	Stainless steel spring washer m10	57002150
Package: Motor with reduction gearbox (D)		
Quantity	Description	VDEG Part No.
1	Enmix motor with reduction gearbox	Various
Package: Shaft guide (E)		
Quantity	Description	VDEG Part No.
1	Stainless steel frame shaft guide (7)	55022820
1	Stainless steel plate bush + slide bearing (9)	55003950
4	Stainless steel hexagon tap bolt m8x10	57005900
2	Stainless steel hexagon tap bolt m8x25	57005940
2	Stainless steel self-locking nut m8	57004140
8	Stainless steel fender washer m8	57000140

Exploded view



Overview of dimensions

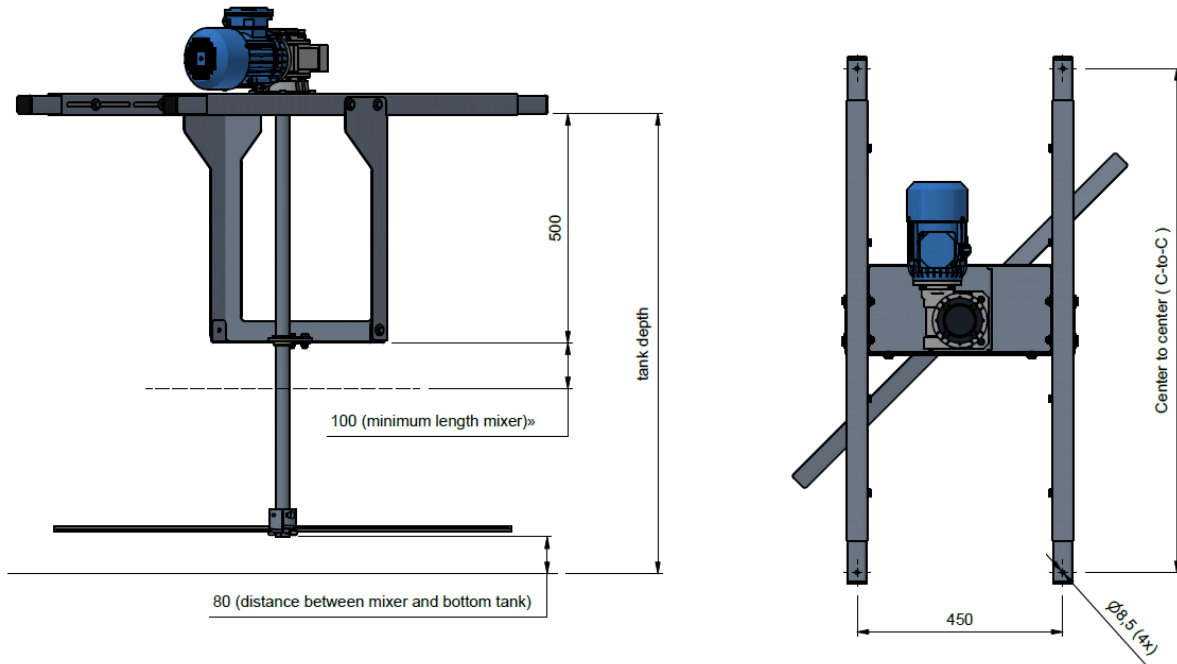

	minimum C-to-C distance	maximum C-to-C distance
Frame short	1100	1780
Frame long	1780	2460
	minimum tank depth	maximum tank depth
Mixer short	180	1000
Mixer long (including shaft guide)	680	1500



Lubricants Report



Product Data Sheet from Shell Lubricants

PDS#4.03.01

Shell Cassida* Fluid GL

Gear lubricants for use in food manufacturing equipment

Shell Cassida Fluid GL 220 and 460 are high performance, anti-wear gear oils specially developed for the lubrication of enclosed gears in food and beverage processing machinery.

They are based on a careful blend of synthetic fluids and selected additives chosen for their ability to meet the stringent requirements of the food industry.

Registered by NSF (Class H1) for use where there is potential for incidental food contact. These products meet the guidelines (1998) of, and were previously authorized by, the US Department of Agriculture Food Safety and Inspection Service (USDA FSIS) for H1 use (lubricant with incidental food contact) and listed in Miscellaneous Publication No 1419 "List of Proprietary Substances and Nonfood Compounds". Product contain only substances permitted under US 21 CFR 178.3570, 178.3620 and 182 for use in lubricants with incidental food contact.

Applications

- Lubrication of enclosed gearboxes used in the food industry.
- Also intended for use in equipment manufacturing food packaging

Performance Features

- Resists the formation of harmful products of oxidation even at elevated temperatures
- Base oil has an ability to provide superior lubrication under all operating conditions
- Excellent EP properties make Shell Cassida Fluid GL suitable for steel-on-steel and worm and phosphor-bronze wheel applications
- Neutral odour and taste
- High viscosity index resulting in minimum variation of viscosity with change in temperature

Seal and Paint Compatibility

Compatible with the elastomers, gaskets, seals and paints normally used in food machinery lubrication systems.

Specifications and Certificates

- NSF H1
- CFIA
- Kosher
- Halal
- DIN 51517 CLP
- ISO/DP 6743/6

Synthetic lubricants

- Do not contain any natural products derived from animals, nuts or genetically modified organisms (GMOs).
- Suitable for use where vegetarian and 'nut-free' food is prepared.
- Biostatic; do not promote the growth of bacteria or fungal organisms.

Approvals & Recommendations

This is an ongoing process, please contact your Shell representative for any updates.

- David Brown: Shell Cassida GL 460 for worm gears
- Lenze
- Getriebbau Nord: Shell Cassida GL 220
- Flender, Krones
- SEW (GL220 for helical units & GL460 for worm gear units)
- Bonfiglioli (for parallel shaft and helical in-line reducers; Cassida GL 460 for worm or worm/screw gears),
- FMC can seamers (viscosity for different models according to OEM specification).
- FAG and Buehler recommendation
- Westfalia Food Tec (Cassida GL 220)
- Stork Food and Dairy Systems

"Incidental Food contact"

Registered by NSF (Class H1) and meet the USDA H1 guidelines (1998) for lubricants for use where there is a potential for incidental food contact.

Made only from substances permitted under the US FDA Title 21 CFR 178.3570, 178.3620 and/or those generally regarded as safe (US 21 CFR 182) for use in food grade lubricants. To comply with the requirements of US 21 CFR 178.3570, contact with food should be avoided where possible. In the case of incidental food contact, the concentration of this product in the food must not exceed 10 parts per million (10mg/kg of foodstuff).

In locations and/or applications where local legislation does not specify maximum concentration limits, Shell recommends that this same 10 ppm limit be observed, as up to this concentration Shell Cassida Fluid GL will not impart undesirable taste, odour or colour to food, nor will cause adverse health effects.

Consistent with good manufacturing practice, use only the amount necessary to achieve correct lubrication and take appropriate corrective action should excessive incidental contact with food be detected

Health and Safety

Based on information available, Shell Cassida Fluid GL are unlikely to present any significant health or safety hazard when properly used in the recommended application and good standards of industrial and personal hygiene are maintained. As for all oils, prolonged or repeated contact with the skin should be avoided.

For further information refer to the appropriate Shell Material Safety Data Sheet.

Handling and storage

All food grade lubricants, such as Shell Cassida Fluid GL, should be stored separately, out of direct sunlight or other heat sources, from other lubricants, chemical

substances and foodstuffs. Store between 0°C and 40°C. Under these conditions the recommended shelf life of this product, unopened, is 5 years from date of manufacture. Consult your Shell representative for details. Accept for use new Shell Cassida Fluid GL only if the manufacturer's seal is intact.

Before opening the pack ensure the area around the closure is clean. It is recommended that it be cleaned with Shell Cassida Fluid PL and/or potable water.

Record the date the seal was broken. To prevent product contamination, always close the package after use. Use the product within 2 years of opening the pack.

Oil condition during use

It is recommended that the condition of the oil and the equipment be regularly checked to ensure safe operation.

Protect the environment

Take used lubricants and empty packs to an authorised collection point. Do not discharge into drains, soil or water.

Typical characteristics

Shell Cassida Fluid GL			220	460
Product Code			407-091	407-093
Property	Test method			
NSF Registration No.			92535	92537
Colour			Colourless, pale yellow	
Density at 15°C	kg/m ³	ISO 12185	847	855
Flashpoint	°C	ISO 2592	276	270
Pourpoint	°C	ISO 3016	-48	-45
Kin. Visc. at 40°C	mm ² /s	ISO 3104	220	460
Kin. Visc. at 100°C	mm ² /s	ISO 3104	25,0	43,8
Viscosity index		ISO 2909	143	148
FZG-Test A/8.3/90	Failure Load Stage	DIN 51354	> 12	

These characteristics are typical for current production. Variations in these characteristics may occur.

Produced according to Shell Quality Standards, in facilities where HACCP audit and Good Manufacturing Practice have been implemented and form part of the quality/environment management system ISO 9001/ ISO 14001.

Visit your nearest Shell Associate or Reseller for more details.

Need more information? Please contact the Shell Helps Centre Technical Desk at 1-800-861-1600 or e-mail us at questions@shell.com

MSDS requests? Please call 1(403) 691-3321

*Trademarks of Shell Canada Limited. Used under license by Shell Canada Products.

10/18/2005 11:30 AM



The information in this manual is provided to the best of our knowledge and ability, and no rights may be derived from this information. It is subject to printing and typesetting errors and changes in technology and working methods. Any liability for consequential damage is excluded.



Aartsdijkweg 23, 2676 LE Maasdijk, The Netherlands
+31 174 51 50 50 · info@vanderendegroup.com · www.vanderendegroup.com