

COURSE

Danfoss VLT[®] AQUA Drive FC 202



Version: 26.09A

TABLE OF CONTENTS

Table of contents	2
Foreword.....	3
1 Safety	4
2 Cabling and display	6
2.1 Cable diameter and fuses	6
2.2 Shielded cables	6
2.3 Key description	7
3 Parameters.....	8
3.1 Viewing and changing a parameter	8
3.1.1 Adjusting the multimonitor menu	8
3.2 Parameter group settings	9
3.3 Saving and loading parameter settings	10
3.4 Factory default.....	10
3.5 Errors and alarms	11
3.5.1 Error descriptions.....	11
3.6 Monitoring values.....	13
3.7 Connection terminals.....	14
4 MCT10	15
5 Follow-up Control.....	16
5.1 Example fellow-up control (various)	16
5.2 Application example 0 - 10 Volt tracking control.....	17
5.3 Application example 4 - 20 mA tracking control.....	18
5.4 Application example Up – down control	19
6 PID systems	20
6.1 PID heating	20
6.1.1 Example heating (PID)	20
6.1.2 Application example PID control.....	21
6.2 PID hydrophore	22
6.2.1 Example hydrophore	22
6.2.2 Application example PID control.....	23
6.2.3 Optional PID 2 references.....	24
6.3 Adjustment aid for hydrophore systems.....	25
7 Cascade 2.0	26
7.1 Example cascade controller.....	26
7.2 Modbus Multi-master cascade controller	27
7.3 Adjustment aid for determining switch-on and switch-off values	27
7.4 Parameters for cascade control	28
7.4.1 Settings for FC 202 master and backup master	28
7.4.2 Settings for FC 202 (102) follower.....	30
8 Notes.....	31

FOREWORD

This course book is provided to those who have completed the Danfoss VLT AQUA FC 202 course at Van der Ende Group. It is also provided with every Danfoss VLT AQUA FC 202.

The course book is also intended as a handy, abridged manual for commissioning the Danfoss VLT AQUA FC 202. A few example applications are also mentioned in this book. We therefore strongly advise you to always read the original manuals supplied with the controller carefully.

No rights can be derived from the contents of this course book. Errors and/or typographical errors that may cause incorrect settings and/or damage to the controller or connected machines cannot give rise to claims for compensation or warranty and are expressly rejected by us.

The parameters mentioned in this booklet are only examples; no rights can be derived from them.

Copyright Van der Ende Group

No part of this publication may be reproduced or published without the written permission of Van der Ende Group.

1 SAFETY



**ONLY QUALIFIED PERSONNEL MAY PERFORM WORK
ON THE ELECTRICAL INSTALLATION**



 WARNING	1	The components of the frequency converter's power supply unit are live when the VLT AQUA FC 202 is connected to the mains. Contact with this voltage is life-threatening and can cause serious injury or death. The control unit is potential-free.
	2	The Danfoss FC 202 has a leakage current of 3.5 mA AC according to EN61800-5-1.
	3	If the frequency converter is part of a machine, the machine manufacturer is responsible for installing a machine main switch (EN 60204-1).
	4	Only spare parts supplied by Danfoss may be used.
	5	Before performing (insulation) measurements on the motor or motor cables, the motor cables must be disconnected from the frequency converter.
	6	Do not touch the IC circuits on the boards. Static voltage can damage the components.
	7	Check that the EMC value of the frequency converter matches the value required by the environment.
	8	The motor starts automatically if you have set the parameter setting response after fault message to automatic. Read more about this in the application manual.
	9	The VLT AQUA FC 202 frequency converter must be used for permanent installations.
	10	Please note that the frequency converter may start automatically when it receives power. Therefore, disconnect the motor from the frequency converter if an unexpected motor start could pose a hazard.

	1	The motor terminals U, V, W and the DC rail/braking resistor terminals –/+ are live when the VLT AQUA FC 202 is connected to the mains, even if the motor is not running.
	2	The I/O connections for the controls are potentially isolated from the network. However, the relay outputs and other I/O connections may have a dangerous external voltage even if the VLT AQUA FC 202 is disconnected from the power supply network.
	3	Before connecting the frequency converter to the mains, check that the VLT AQUA FC 202 covers and cable connections are covered.
	4	Do not perform any measurements while the frequency converter is connected to the network.
	5	After disconnecting the frequency converter from the network, wait until the fan stops and the control panel switches off (if no panel is installed, check the lights on the cover). Wait 5 minutes before performing any work on the VLT AQUA FC 202 connection terminals. Do not even open the cover before this time has elapsed.
	6	Do not perform insulation measurements on the VLT AQUA FC 202. There is a special procedure for performing such tests. Failure to follow this procedure may result in damage to the product.

Safety instructions

Grounding and ground fault protection

The VLT AQUA FC 202 frequency converter must always be grounded at the grounding terminal 

2 CABLING AND DISPLAY

2.1 Cable diameter and fuses

For more information about cable diameters and fuses, refer to chapter 7 of the design guide.

2.2 Shielded cables

The control signal and motor cables must be shielded to comply with radio interference regulations in accordance with IEC 61800-3 category C2/C3 and EMC specifications. The shielding of the motor and control cables must be connected to the ground terminal in the frequency converter and in the motor or sensors, PLC, etc.

If unshielded cables are used, signal interference may occur at the control inputs. Such interference will not normally cause damage to the frequency converter, but it will disrupt the control system.

	RFI filter	
	H1	H3
Max. motor cable length	150 m	50 m

Please note!!! Reinforcement intended as mechanical protection (e.g., ground cable) is not suitable for EMC-compliant installation.

Our preference for the use of signal cables is for cables with twisted cores.

2.3 Key description

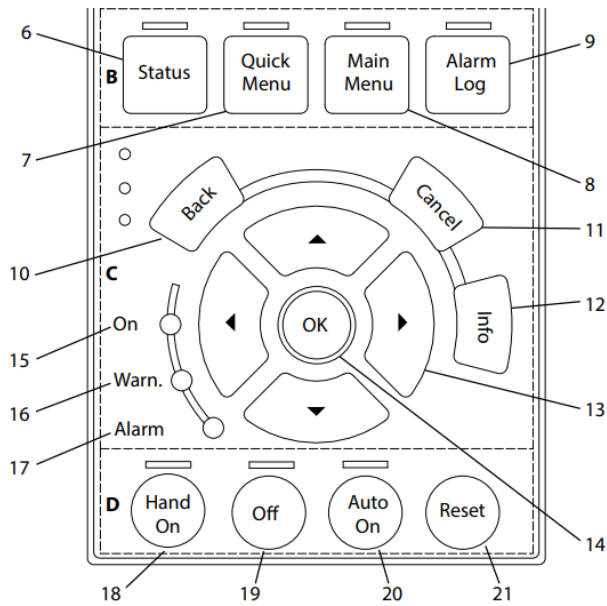

Pos.	Key	Function
6	Status	Displays the operating data.
7	Quick Menu	Provides access to the parameters for programming the initial setup.
8	Main Menu	Provides access to all programmable parameters.
9	Alarm Log	Displays an overview of active warnings, the last 10 alarms, and the maintenance log.
10	Back	Returns you to the previous step in the menu structure.
11	Cancel	Cancels your last change or command.
12	Info	Press this to display a description of the selected function.
13	Navigation keys	Press to move to other options in the menu.
14	OK	This allows you to access parameter groups or confirm a selection.
18	Hand On	Start the frequency converter in local control.
19	Off	Stops the motor.
20	Auto On	Sets the system to external control mode.
21	Reset	This allows you to manually reset the frequency converter.

3 PARAMETERS

3.1 Viewing and changing a parameter

As an example, we want to view and change the minimum frequency (P 4-12). Press the Main Menu button (8), select "Limits / Warnings" and press OK(14). Select menu "4-1 Motor limits" and press OK (14). Use the navigation keys (13) to scroll down and select parameter "4-12 Motor speed Low limit", then press OK (14) to adjust the parameter. To return to the main menu, press Status (6).

3.1.1 Adjusting the multimonitor menu

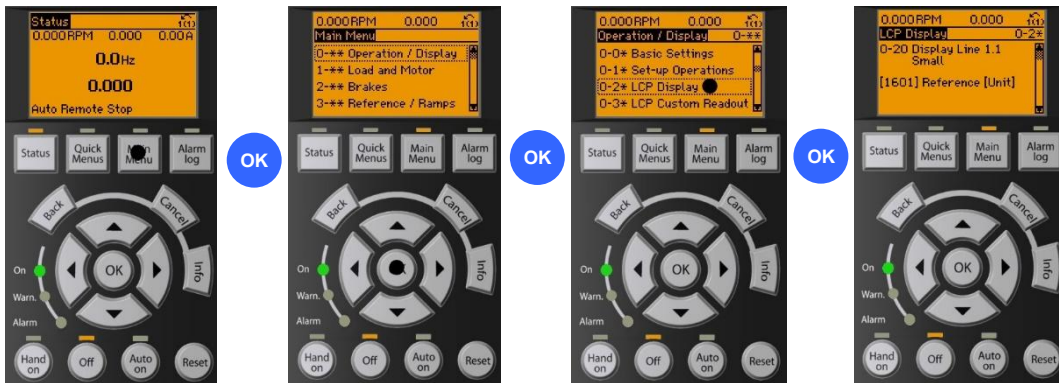

To adjust the display fields, follow the steps below:

1. Press Main Menu (8);
2. The "Operation/Display" menu is selected; press OK (14);
3. Select "LCP Display" and press OK (14);
4. Select the desired display line and press OK (14);
5. Now enter the desired parameter, see section 3.5, and press OK (14).
6. To return to the main menu, press Status (6).

3.2 Parameter group settings

This parameter group contains the following menus:

Group	Function
0-** Operation/display	Parameters relating to the basic functions of the frequency converter, the function of the LCP keys, and the configuration of the LCP display.
1-** Load & motor	Parameters for motor settings.
2-** Brakes	Parameters for setting brake functions in the frequency converter.
3-** Ref./Ramp.	Parameters for using references, setting limits, and configuring the frequency converter's response to changes.
4-** Limit/warning.	Parameters for configuring limits and warnings.
5-** Digital In/Out	Parameters for configuring the digital inputs and outputs.
6-** Analog In/Out	Parameters for configuring analog inputs and outputs.
8-** Comm. and options	Parameter group for configuring communication and options.
9-** PROFIdrive	Parameter group for Profibus-specific parameters (VLT® PROFIBUS DP MCA 101 required)
10-** CAN fieldbus	Parameter group for DeviceNet-specific parameters (VLT® DeviceNet MCA 104 required).
13-** Smart Logic	Parameter group for Smart Logic Control.
14-** Special functions	Parameter group for configuring special functions of the frequency converter.
15-** Drive info	Parameter group with information about the frequency converter, such as operating data, hardware configuration, and software versions.
16-** Data readouts	Parameter group for data readouts, such as current references, voltage, control, alarms, warnings, and status words.
18-** Info & readouts	This parameter group contains the last 10 logs for preventive maintenance.
20-** Inverter with feedback	This parameter group is used to configure the PID controller for feedback that controls the output frequency of the unit.
21-** Output with feedback	Parameters for configuring the 3 PID controllers for extended feedback.
22-** Application functions	Parameters for water applications.
23-** Time-based functions	Parameters for actions to be performed on a daily or weekly basis.
24-** Application functions 2	Parameters for the frequency converter bypass.
25-** Cascade controller	Parameters for configuring the standard cascade controller for sequential control of multiple pumps.
26-** Anal. I/O option MCB 109	Parameters for configuring the VLT® Analog I/O MCB 109.
27-** Cascade CTL option	Parameters for configuring the extended cascade control.
29-** Water Application Functions	Parameters for setting water-specific functions.
30-** Special Functions	Parameters for configuring special functions.
31-** Bypass option	Parameters for configuring the bypass function.
35-** Sensor input option	Parameters for configuring the sensor input function.

3.3 Saving and loading parameter settings

To copy and load parameters using the display (LCP), perform the steps below.

- Set parameter 0-50 to (1) OK (copy everything to LCP)
- Set parameter 0-50 to (2) OK (load everything from LCP)

3.4 Factory default

To reset to factory settings, follow the steps below.

- Set parameter 14-22 to initialize (2);
- Press OK;
- Disconnect the controller from the power supply;
- Reconnect the power supply to the controller;
- The controller will display "initializing";
- The controller now has the factory settings.

The second possibility to reset the controller to factory default is:

- Connect the power supply to the controller;
- Hold down the following keys;
 - o Status;
 - o Main Menu;
 - o OK;
- The controller will display "initializing";
- The controller now has the factory settings.

3.5 Errors and alarms

Active errors and error history are displayed in the Alarm Log menu (keypad "9").

3.5.1 Error descriptions

The table below shows all possible error codes with the corresponding description.

	Warning
	Programmable with parameter
	Alarm
	No action or immediate notification

Code	Alarm
1	10 V too low
2	Live zero error
3	No motor
4	Mains phase loss
5	DC link voltage high
6	DC link Voltage low
7	DC overvoltage
8	DC undervoltage
9	Inverter overloaded
10	Motor ETR overtemperature
11	Thermistor overtemperature
12	Torque limitation
13	Overcurrent
14	Ground fault
15	Incompatible hardware
16	Short circuit
17	Control word timeout
18	Start failed
20	Temperature input error
21	Parameter error
22	Mechanical brake in hoisting application
23	Internal fans
24	External fans
25	Short circuit braking resistor
26	Brake resistor power limitation
27	Short circuit brake chopper
28	Brake test
29	Temp. Heat sink
30	Motor phase U missing
31	Motor phase V missing
32	Motor phase W missing
33	Inrush error
34	Fieldbus communication error
35	Optical error
36	Power failure
37	Phase imbalance
38	Internal error
39	Sensor heat sink
40	Overload DI terminal 27
41	Overload DI terminal 29
42	Overload X30/6-7
43	External power supply (optional)
45	Ground fault 2
46	Input card power supply
47	24V power supply low
48	1.8V low power supply
49	Speed limit
50	AMA calibration failed
51	AMA check Unom and Inom
52	AMA low Inom

Code	Alarm
53	AMA engine too large
54	AMA engine too small
55	AMA parameters out of range
56	AMA interrupted by user
57	AMA timeout
58	AMA internal error
59	Current limitation
60	Ext. Lock
61	Feedback error
62	Output frequency at max. limit
63	Mechanical brake low
64	Voltage limit
65	Control card overtemperature
66	Heat sink temperature low
67	Option configuration has been changed
68	Safe torque off
69	Power supply card temperature
70	Invalid FC configuration
71	PTC 1 Safe torque off
72	Dangerous malfunction
73	Automatic restart STO
74	PTC thermistor
75	Invalid profile
76	Power unit setup
77	Low power mode
78	Tracking error
79	Invalid PS configuration
80	Frequency set to default value.
81	CSIV corrupt
82	CSIV parameter error
83	Invalid option combination
84	No safety option
88	Option detection
89	Mechanical brake slides
90	Feedback monitoring
91	AI 54 incorrectly set
92	No flow
93	Dry pump
94	End of curve
95	Defective tire
98	Clock error
163/166	Atex
200	Emergency mode
201	Fire mode was active
25	New spare part
251	New type code

3.6 Monitoring values



The overview below contains the most common settings for the monitoring fields. Other settings can be found in section 3.2.3 of the programming manual.

Code	Option	Function
0	None	No display value selected
89	Date and time display	
1501	Number of operating hours	Displays the number of hours the motor has been in operation.
1601	Reference (unit)	Total reference in the selected unit.
1602	Reference %	Total reference in percent
1610	Power (kW)	Current motor power in kW
1612	Motor voltage	Voltage supplied to the motor
1614	Motor current	Phase current of the motor, measured as effective value.
1615	Frequency (%)	Motor frequency
1616	Torque (Nm)	Current motor load as a percentage of nominal motor torque
1617	Speed (RPM)	Speed in RPM
1618	Motor therm.	Thermal load of the motor
1623	Engine shaft power (kW)	Reading of the mechanical power delivered by the engine shaft.
1630	DC connection voltage	DC intermediate circuit voltage in the frequency converter.
1634	Heat sink temperature	Current temperature of the heat sink
1658	DIP output (%)	Displays the output value of the DIP controller with feedback as a percentage
1660	Digital input	Displays the status of the digital inputs.
1662	Analog input 53	The current value of input 53
1664	Analog input 54	The current value of input 54

3.7 Connection terminals

Terminals of the standard drives.

Basic I/O board			
Connection terminal		signal	description (PID settings)
50	+10V _{ref}	Reference output	Power supply for potentiometer, etc.
53	AI1+	Analog input, 0-10Vdc or 0/4-20 mA	Voltage input for frequency reference
54	AI2+	Analog input 0-10Vdc or 0/4-20mA	Programmable current input
55	AI-	Analog input ground	
12	+24V	Control voltage output	Power supply for contacts, etc. max 0.1A
13	+24V	Control voltage output	Power supply for contacts, etc. max 0.1A
18	DI	Digital input	
19	DI	Digital input	
20	GND	I/O ground	Ground inputs and outputs
27	DI	Digital input	
29	DI	Digital input	
32	DI	Digital input	
33	DI	Digital input	
37	DI	Digital input	
39	AO1+	Analog output	Programmable range 0/4 - 20mA
42	AO-/GND		
61	GND	COM RS-485	
68	+	P RS-485	
69	-	N RS-485	

Relay board 1				
1	RO1 com		Relay output 1	Programmable
2	RO1 no			
3	RO1 nc			
4	RO2 com		Relay output 2	Programmable
5	RO2 no			
6	RO2 nc			

4 MCT10

In MCT10, you can change and view the parameters via your PC.

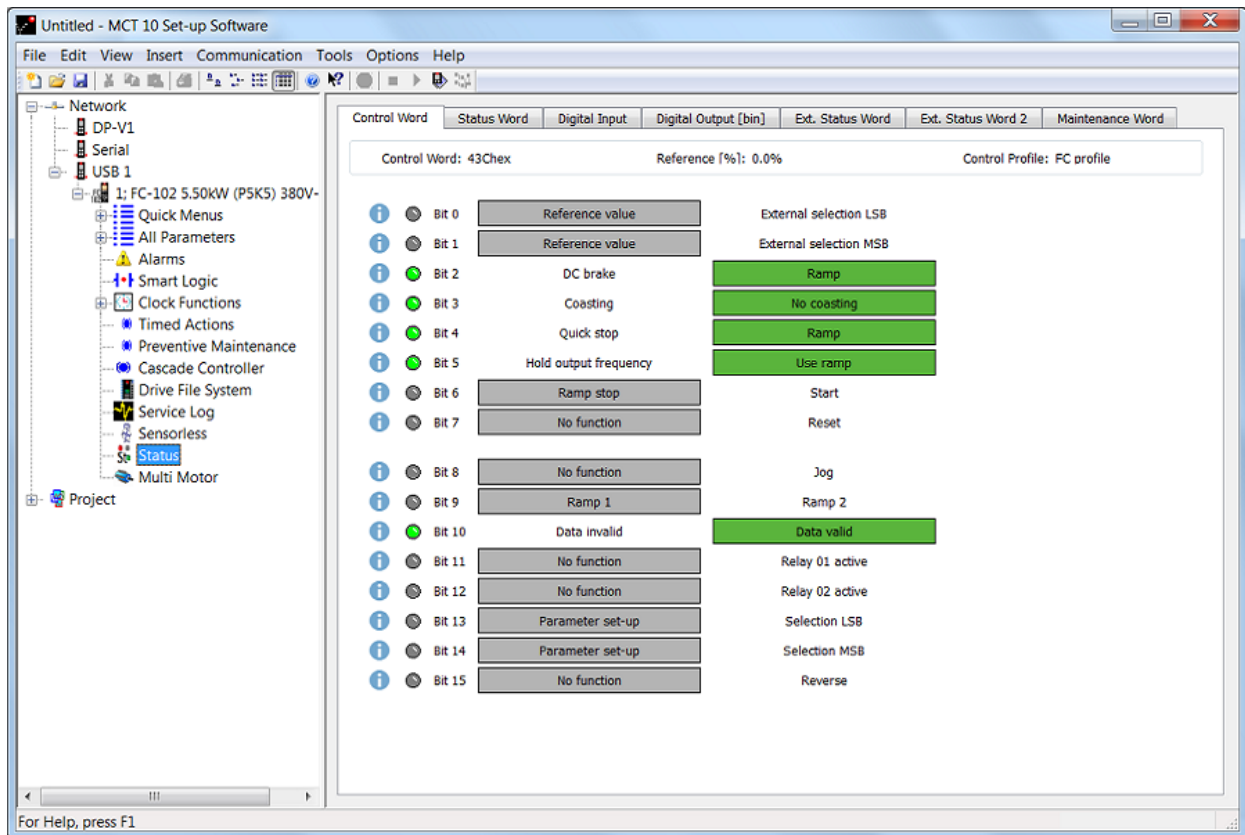

Warning!!!! RISK OF DAMAGE TO PC USB PORT



When the PC is connected to the controller via the USB cable, there is a risk that the USB port on the PC may be damaged.

- Follow the grounding recommendations as described in the operating manual for the relevant inverter.
- Use a USB isolator with galvanic isolation to protect the PC's USB port from ground potential differences when: the PC is connected to a controller via a USB cable.
- DO NOT use a PC power cable with a grounded plug when the PC is connected to the controller via a USB cable.

5 FOLLOW-UP CONTROL

All applications mentioned below are based on working from the [3.4 Factory default](#).

5.1 Example fellow-up control (various)

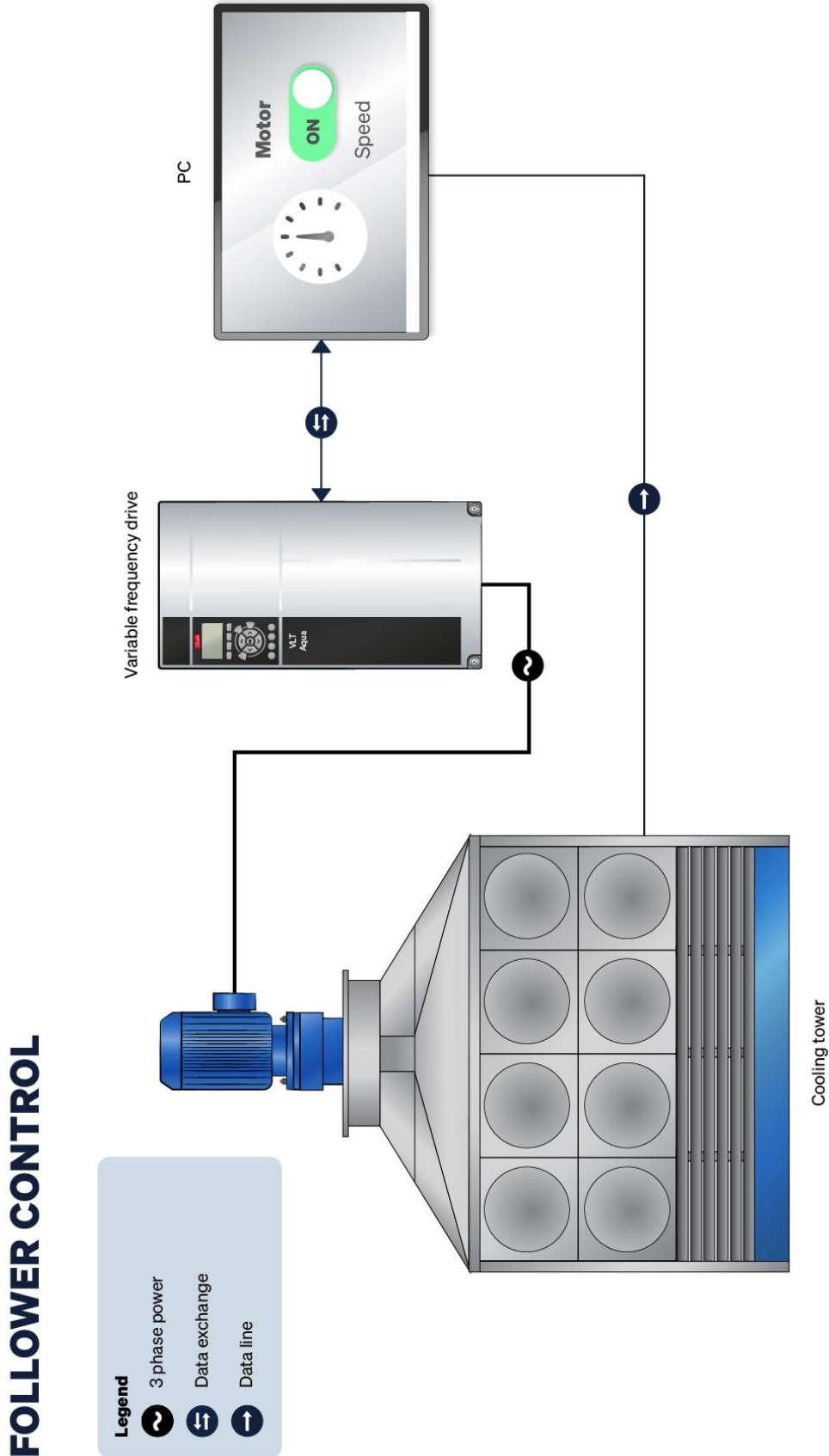

5.2 Application example 0 - 10 Volt tracking control

Parameter	Description	Setting	Code
0-01	Language	English	0
0-02	Engine speed unit	Hz	1
0-20	Display line 1.1 small	Reference	1601
0-21	Display line 1.2 small	none	0
0-22	Display line 1.3 small	Analog input 53	1662
0-23	Display line 2 large	Frequency	1613
0-24	Display line 3 large	Motor current	1614
1-20	Motor power	Nominal motor power in kW nameplate	
1-22	Motor voltage	Nominal motor voltage in volts on nameplate	
1-23	Motor frequency	Nominal motor frequency in Hz on nameplate	
1-24	Motor current	Nominal motor current in amps. Nameplate	
1-25	Motor speed	Nominal motor speed in rpm nameplate	
3-02	Minimum reference	Minimum frequency	
3-03	Maximum reference	maximum frequency	
3-15	Reference source 1	Analog input 53	1
3-41	Ramp 1 start-up time	10 sec	
3-42	Ramp 1 run-out time	10 sec	
4-14	Motor speed high	Maximum frequency	
5-01	Terminal 27 mode	Input	0
5-02	Terminal 29 mode	input	0
5-10	Terminal 18 digital input	Start	8
5-11	Terminal 19 digital input	Not in use	0
5-12	Terminal 27 digital input	Not in use	0
5-13	Terminal 29 digital input	Not in use	0
5-14	Terminal 32 digital input	Not in use	0
5-15	Terminal 33 digital input	Not in use	0
6-10	Terminal 53 Low voltage	0 volts (or 2)	
6-11	Terminal 53 High voltage	10 volts	
6-15	Terminal 53 high reference	Maximum frequency	
14-01	Switching frequency	Adjust if excessive motor noise	
1-29	Automatic adjustment (AMA)	Limited AMA / Full AMA with separate motor	2

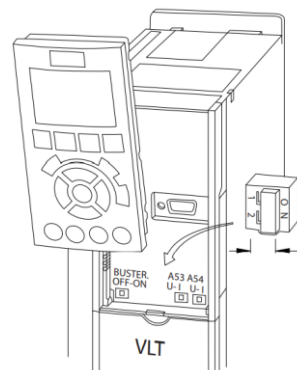

- Ensure that switch A53 is set to voltage (U), see image above.
- The 0-10 Volt signal is connected to AI1 on terminals 53 (+) and 55 (-).
- The tracking control is started by connecting 18 (DI) to 12 (+24 V).

5.3 Application example 4 - 20 mA tracking control

Parameter	Description	Setting	Code
0-01	Language	English	0
0-02	Engine speed unit	Hz	1
0-20	Display line 1.1 small	Reference	1601
0-21	Display line 1.2 small	none	0
0-22	Display line 1.3 small	Analog input 54	1664
0-23	Display line 2 large	Frequency	1613
0-24	Display line 3 large	Motor current	1614
1-20	Motor power	Nominal motor power in kW nameplate	
1-22	Motor voltage	Nominal motor voltage in volts on nameplate	
1-23	Motor frequency	Nominal motor frequency in Hz on nameplate	
1-24	Motor current	Nominal motor current in Amp. nameplate	
1-25	Motor speed	Nominal motor speed in rpm nameplate	
3-02	Minimum reference	Minimum frequency	
3-03	Maximum reference	maximum frequency	
3-15	Reference source 1	Analog input 54	2
3-41	Ramp 1 start-up time	10 sec	
3-42	Ramp 1 runout time	10 sec	
4-14	Motor speed high	Maximum frequency	
5-01	Terminal 27 mode	Input	0
5-02	Terminal 29 mode	input	0
5-10	Terminal 18 digital input	Start	8
5-11	Terminal 19 digital input	Not in use	0
5-12	Terminal 27 digital input	Not in use	0
5-13	Terminal 29 digital input	Not in use	0
5-14	Terminal 32 digital input	Not in use	0
5-15	Terminal 33 digital input	Not in use	0
6-22	Terminal 54 Low voltage	0 mA Volt (or 4)	
6-23	Terminal 54 High voltage	20 mA	
6-25	Terminal 54 high reference	Maximum frequency	
14-01	Switching frequency	Adjust in case of excessive motor noise	
1-29	Automatic adjustment (AMA)	Limited AMA / Full AMA with separate motor	2

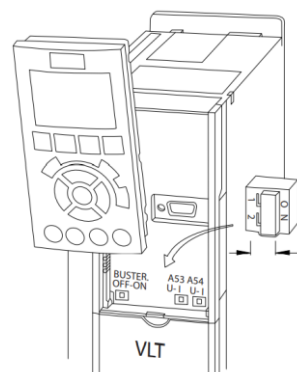

- Ensure that switch A54 is set to current (I), see image above.
- The 4-20 mA signal is connected to AI 2 on terminals 54 (+) and 55 (-).
- The follow control is started by connecting 18 (DI) to 12 (+24 V).

5.4 Application example Up – down control

Parameter	Description	Setting	Code
0-0	Language	English	0
0-02	Engine speed unit	Hz	1
0-20	Display line 1.1 small	Reference	1601
0-21	Display line 1.2 small	none	0
0-22	Display line 1.3 small	DigiPot Reference %	1653
0-23	Display line 2 large	Frequency	1613
0-24	Display line 3 large	Motor current	1614
1-20	Motor power	Nominal motor power in kW nameplate	
1-22	Motor voltage	Nominal motor voltage in volts on nameplate	
1-23	Motor frequency	Nominal motor frequency in Hz on nameplate	
1-24	Motor current	Nominal motor current in Amp. nameplate	
1-25	Motor speed	Nominal motor speed in rpm nameplate	
3-02	Minimum reference	Minimum frequency	
3-03	Maximum reference	maximum frequency	
3-15	Reference source 1	Digital potentiometer	20
3-41	Ramp 1 start-up time	50 sec	
3-42	Ramp 1 run-out time	50 sec	
3-90	Step size	0.10	
3-91	Ramp time	50 sec	
3-92	Voltage recovery	Reference retention after power failure	0
3-93	Maximum limit	100%	
3-94	Minimum limit	10%	
3-95	On/off delay	0	
4-14	Motor speed high	Maximum frequency	
5-01	Terminal 27 mode	Input	0
5-02	Terminal 29 mode	input	0
5-10	Terminal 18 digital input	Start	8
5-11	Terminal 19 digital input	Not in use	0
5-12	Terminal 27 digital input	Not in use	0
5-13	Terminal 29 digital input	Clear DigiPot	57
5-14	Terminal 32 digital input	Increase DigiPot	55
5-15	Terminal 33 digital input	Lower DigiPot	56
6-50	Terminal 42 Analog output	Speed 4-20 mA	137
14-01	Switching frequency	Adjust if excessive motor noise	
1-29	Automatic adjustment (AMA)	Limited AMA / Full AMA with separate motor	2 (1)

- The control is started by connecting 18 (DI 1) to 12 (+24 V).
- Speed up, connect terminal 32 (DI) to 12 (+24 V).
- Speed down, connect terminal 33 (DI) to 12 (+24 V).
- Reset speed, connect terminal 29 (DI) to 12 (+24 V).

6 PID SYSTEMS

All applications mentioned below are based on working from the [3.4 Factory default](#).

6.1 PID heating

6.1.1 Example heating (PID)

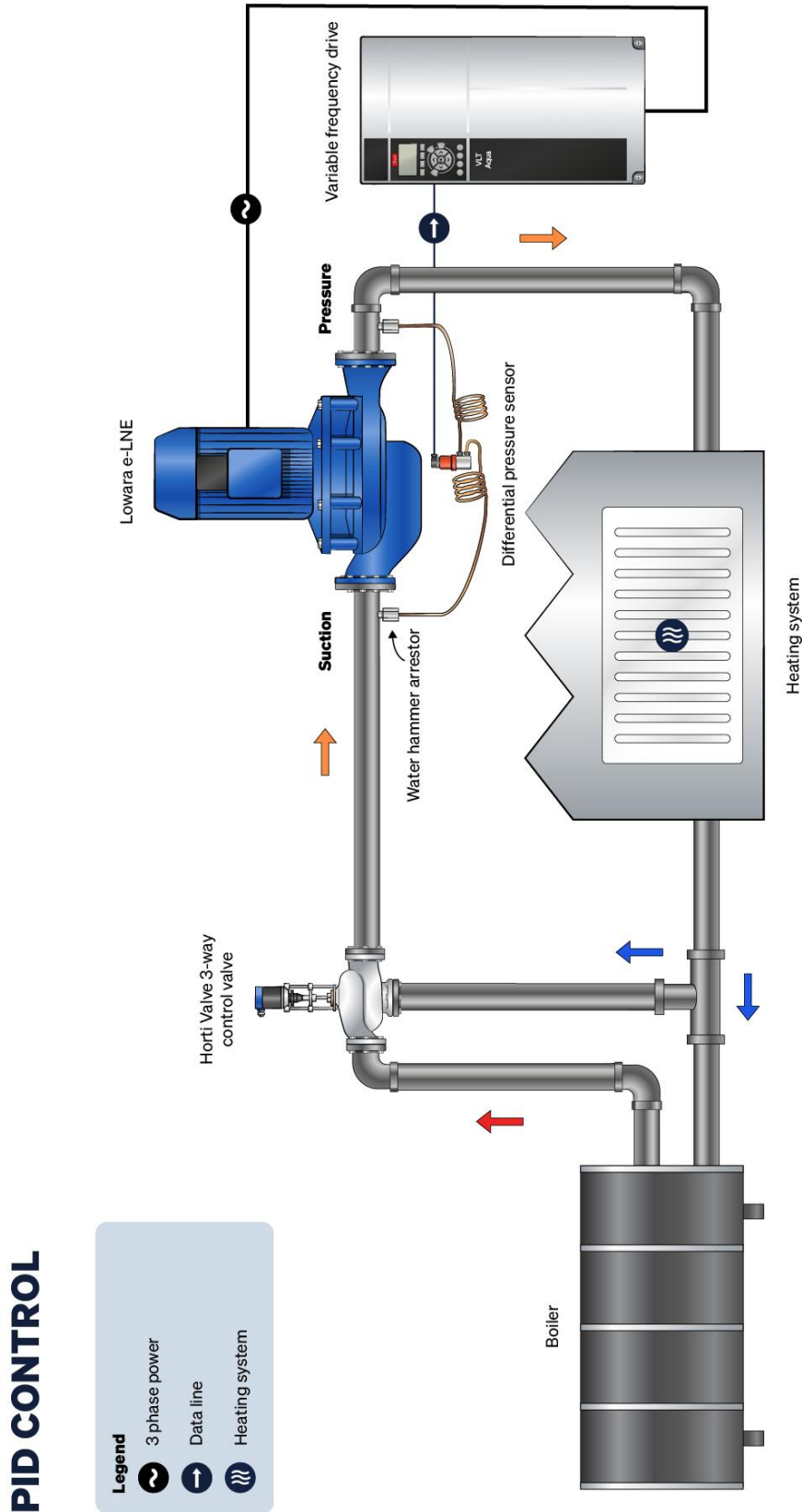

6.1.2 Application example PID control

Parameter	Description	Setting	Code
0-01	Language	Englisch	0
0-02	Engine speed unit	Hz	1
0-20	Display line 1.1 small	Reference	1601
0-21	Display line 1.2 small	none	0
0-22	Display line 1.3 small	Feedback	1652
0-23	Display line 2 large	Frequency	1613
0-24	Display line 3 large	Motor current	1614
1-00	Configuration mode	With feedback	3
1-20	Motor power	Nominal motor power in kW nameplate	
1-22	Motor voltage	Nominal motor voltage in volts on nameplate	
1-23	Motor frequency	Nominal motor frequency in Hz on nameplate	
1-24	Motor current	Nominal motor current in Amp. nameplate	
1-25	Motor speed	Nominal motor speed in rpm nameplate	
20-00	Feedback source 1	Analog input 54	2
20-12	Reference/feedback unit	mbar	70
20-21	Setpoint 1	Enter working pressure	
20-83	PID start speed	5 Hz	
20-93	PID prop. gain	1.0	
20-94	PID integration time	10 sec	
20-95	PID differentiation time	0.5 sec	
3-02	Minimum reference	Minimum working reference (range sensor) 20-12 eg.(0)	
3-03	Maximum reference	Maximum working reference (range sensor) 20-12 eg.(500)	
3-11	Jog speed	30 Hz (fixed frequency)	
3-15	Reference source 1	No function	0
3-41	Ramp 1 start-up time	50 sec	
3-42	Ramp 1 delay time	50 sec	
3-80	Ramp time Jog frequency	50 sec	
4-12	Motor speed Low limit	Minimum frequency (5)	
4-14	Motor speed High limit	Maximum frequency (50/60)	
5-10	Terminal 18 digital input	Start	8
5-11	Terminal 19 digital input	Jog	14
5-12	Terminal 27 digital input	Not in use	0
5-13	Terminal 29 digital input	Not in use	0
5-14	Terminal 32 digital input	Not in use	0
5-15	Terminal 33 digital input	Reset	1
6-00	Live zero timeout	10 sec	
6-01	Live zero function	Stop/trip	5
6-22	Terminal 54 Low voltage	0 mA (or 4)	
6-23	Terminal 54 High voltage	20 mA	
6-24	Terminal 54 low ref feedback.	Minimum sensor value, sensor reading eg.(0)	
6-25	Terminal 54 high ref feedback.	Maximum sensor value, sensor reading eg.(500)	
6-27	Terminal 54 Live zero	on	1
6-50	Terminal 42 analog output	Speed 4-20 mA	137
14-01	Switching frequency	Adjust if excessive motor noise	
14-20	Reset modes	2x auto reset	2
14-21	Automatic reset time	120 sec	
1-29	Automatic adjustment (AMA)	Limited AMA / Full AMA with separate motor	2 (1)

- Ensure that switch A54 is set to current (I).
- The 4-20 mA pressure transducer is connected to AI 2, on terminals 54 (-) and 12 (+).
- PID control is started by connecting 18 (DI) to 12 (+24 V).
- A fault can be reset remotely by connecting 33 (DI) to 12 (+24 V).
- Fixed speed is activated by connecting 19 (DI) to 12 (+24 V); the start contact is not required for this.

6.2 PID hydrophore

6.2.1 Example hydrophore

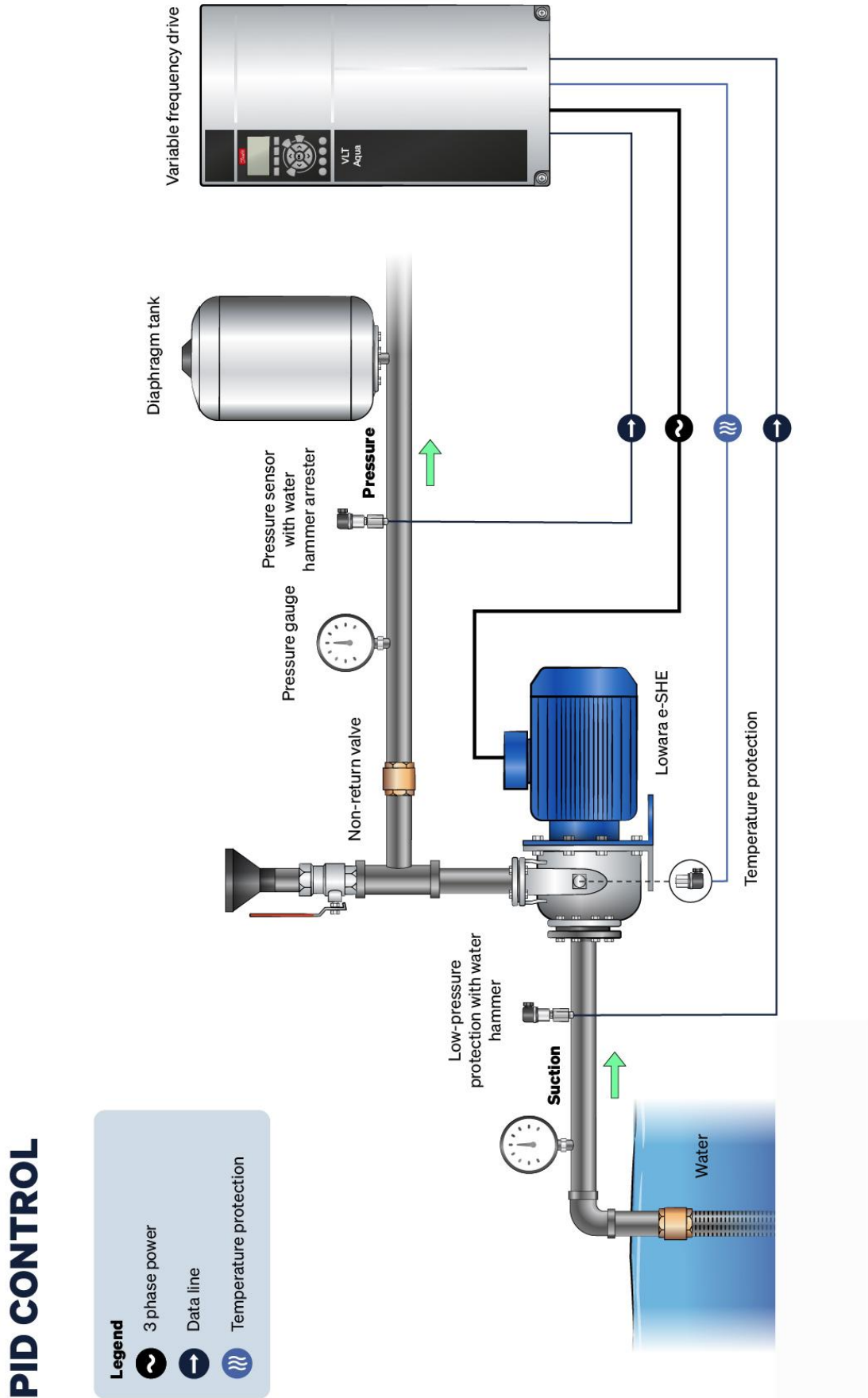

6.2.2 Application example PID control

Parameter	Description	Setting	Code
0-01	Language	Dutch	7
0-02	Engine speed unit	Hz	1
0-20	Display line 1.1 small	Reference	1601
0-21	Display line 1.2 small	none	0
0-22	Display line 1.3 small	Feedback	1652
0-23	Display line 2 large	Frequency	1613
0-24	Display line 3 large	Motor current	1614
1-00	Configuration mode	With feedback	3
1-20	Motor power	Nominal motor power in kW nameplate	
1-22	Motor voltage	Nominal motor voltage in volts on nameplate	
1-23	Motor frequency	Nominal motor frequency in Hz on nameplate	
1-24	Motor current	Nominal motor current in Amp. nameplate	
1-25	Motor speed	Nominal motor speed in rpm nameplate	
20-00	Feedback source 1	Analog input 54	2
20-12	Reference/feedback unit	bar	71
20-21	Setpoint 1	Enter working pressure	
20-83	PID start speed	25 Hz	
20-93	PID prop. gain	2.0	
20-94	PID integration time	3 sec	
20-95	PID differentiation time	0.5 sec	
3-02	Minimum reference	Minimum working reference (range sensor) 20-12	
3-03	Maximum reference	Maximum working reference (range sensor) 20-12	
3-11	Jog speed	40 Hz (fixed frequency)	
3-15	Reference source 1	No function	0
3-41	Ramp 1 start-up time	5 sec	
3-42	Ramp 1 delay time	5 sec	
3-80	Ramp time Jog frequency	40 sec	
4-12	Motor speed Low limit	Minimum frequency	
4-14	Motor speed High limit	Maximum frequency (50/60)	
5-10	Terminal 18 digital input	Start	8
5-11	Terminal 19 digital input	Jog	14
5-12	Terminal 27 digital input	Not in use	0
5-13	Terminal 29 digital input	Not in use	0
5-14	Terminal 32 digital input	Not in use	0
5-15	Terminal 33 digital input	Reset	1
6-00	Live zero timeout	10 sec	
6-01	Live zero function	Stop/trip	5
6-22	Terminal 54 Low voltage	0 mA (or 4)	
6-23	Terminal 54 High voltage	20 mA	
6-24	Terminal 54 low ref feedback.	Minimum sensor value, sensor reading	
6-25	Terminal 54 high ref feedback.	Maximum sensor value, sensor reading.	
6-27	Terminal 54 Live zero	on	1
6-50	Terminal 42 analog output	Speed 4-20 mA	137
14-01	Switching frequency	Adjust if excessive motor noise	
14-20	Reset modes	2x auto reset	2
14-21	Automatic reset time	120 sec	

PTO

Parameter	Description	Setting	Code
13-40.0	Logic Rule Boolean 1	Digital input DI27	35
13-41.0	Logic Rule Operator 1	NOT OR	6
13-90.0	Alert Trigger	Logic rule 0	26
13-91.0	Alert Action	Trip w manual reset	13
13-92.0	Alert Text	Water temperature	
22-22	Low speed detection	enabled	1
22-23	No flow function	sleep mode	1
22-24	Delay no flow	10 sec	
22-29	No flow low speed freq.	Frequency at which pump has no function	
22-40	Minimum running time	10 sec	
22-41	Minimum stop time	2 sec	
22-44	Reaction/feedback difference	5	
22-45	Boost setting	10	
22-46	Maximum boost time	15 sec	
1-29	Automatic adjustment (AMA)	Limited AMA / Full AMA with separate motor	2 (1)

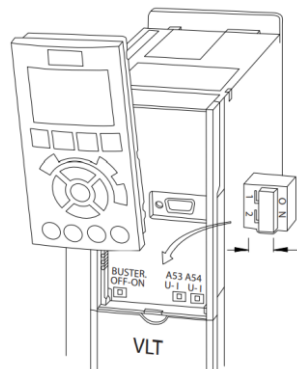

- Ensure that switch A54 is set to current (I), see image above.
- The 4-20 mA pressure transducer is connected to AI 2, on terminals 54 (-) and 12 (+).
- PID control is started by connecting 18 (DI) to 12 (+24 V).
- Water thermostat (nc) or float must be connected to 27 (DI) and to 12 (+24V).
- A fault can be reset remotely by connecting 33 (DI) to 12 (+24 V).
- Fixed speed is activated by connecting 19 (DI) to 12 (+24 V); the start contact is not required for this.

6.2.3 Optional PID 2 references

Parameter	Description	Setting	Code
20-21	Setpoint 1	Set this to 0	
3-10.0	Set reference (0)	Pressure in %	
3-10.1	Set reference (1)	Pressure in %	
5-13	Terminal 29 digital input	Set ref. bit0	16

- Switching from desired value 1 to 2 is possible by connecting 29 (DI) to 12 (+24V)

6.3 Adjustment aid for hydrophore systems

To ensure that a hydrophore unit with a Danfoss VLT switches off correctly, a number of parameters must be adjusted as follows:

- Set the VLT AQUA FC 202 to manual control (Hand On "18").
- Ensure that the installation is filled with medium.
- Close the pressure pipe and slowly increase the frequency to the desired value P20-21 (setpoint 1).
- Set the VLT AQUA FC 202 back to automatic (Auto On "20").

Note: For an installation with pre-pressure from a silo.

Ensure that the pre-pressure of the lowest level of the silo is used. If there are large differences in the level and therefore the pre-pressure, the motor may not go below the sleep frequency and the control may not be able to enter sleep mode.

Frequency with a closed pipe and the desired value	Increase the minimum frequency by
up to 40 Hz	± 1.0 Hz
40 to 44 Hz	± 0.7 Hz
44 to 47 Hz	± 0.5 Hz
47 to 49 Hz	± 0.2 Hz

Now enter the minimum frequency obtained according to the table above.

Example:

Frequency with a closed pipe and desired pressure is 44.5 Hz.

Minimum frequency: 45.0 Hz

If the application operates with a 2nd desired value, care must be taken to ensure that the minimum frequency is linked to the lowest desired value.

7 CASCADE 2.0

7.1 Example cascade controller

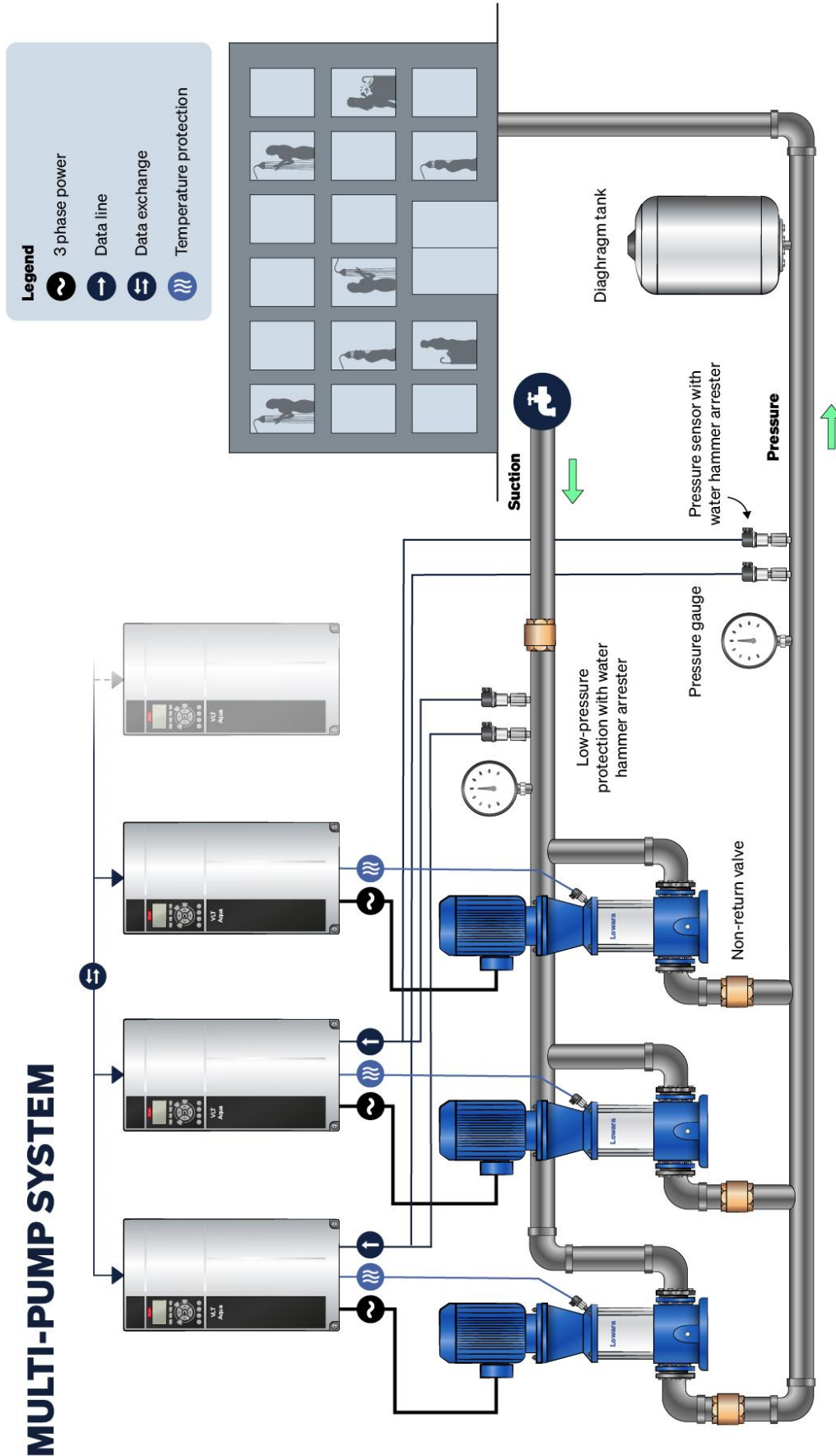

7.2 Modbus Multi-master cascade controller

A license (LXX1) is available for the AQUA drive that allows cascade control to be created with multiple VLT AQUA FC 202 controllers. (maximum of 8 controllers) It is advisable to equip multiple controllers with this license to guarantee the continuity of the installation. Each controller that will serve as a backup controller must be equipped with a feedback source. Using the RS485 bus, the controller equipped with the license can communicate with the other controllers.

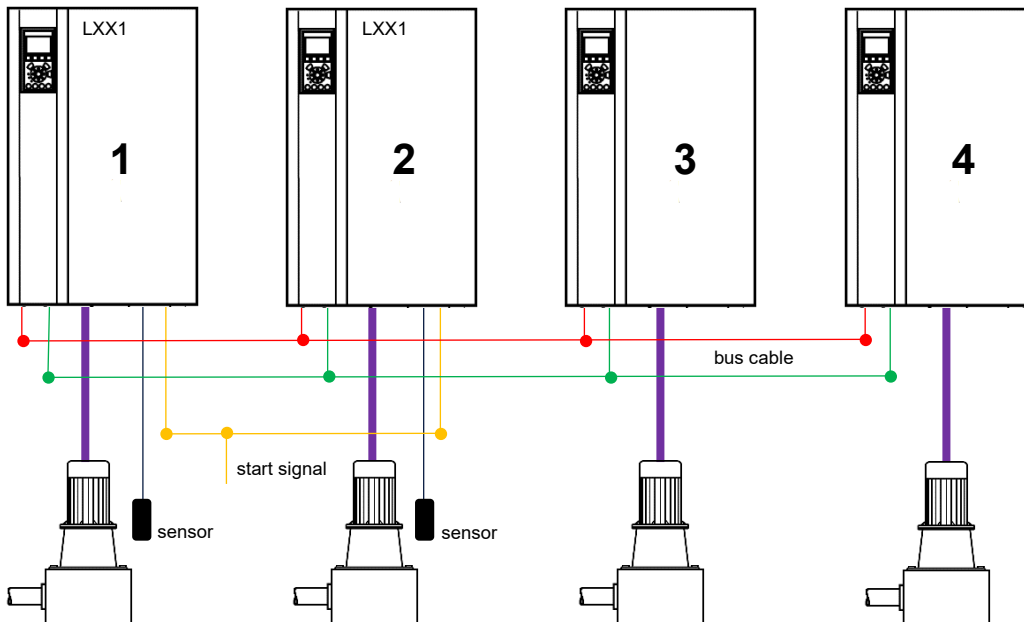

In this configuration, the operating hours are used to determine which motor/pump is activated. If more capacity is required, a motor will be switched on and switched off when demand is lower.

7.3 Adjustment aid for determining switch-on and switch-off values

To determine the value at which the pump set should be awakened from sleep mode and the frequency converters switched on and off, the calculation below can be applied.

Wake up from sleep mode if reference is lower than Setpoint $P20-21$ - (Override limit $P27-21$ x max reference $P3-03$)

For example

$P20-21$ setpoint = 3 bar

$P27-21$ override limit = 10%

$P3-03$ max ref = 10 bar

Wake up from sleep = 3 bar - (10% x 10 bar) = 2 bar

This also means that controllers are switched on if the pressure remains below 2 bar after the override hold time $P27-25$ has elapsed, and controllers are switched off at a pressure above 4 bar after the time $P27-25$ has elapsed.

7.4 Parameters for cascade control

7.4.1 Settings for FC 202 master and backup master

Param.	Description	Setup 1	Setup 2	Code
0-01	Language	Dutch	Dutch	7
0-02	Engine speed unit	Hz	Hz	1
0-10	Active setup	Multi-setup	Multisetup	9
0-12	Link setup to	Setup 2	Setup 1	2/1
0-20	Display line 1.1 small	Reference	Motor current	1601/1614
0-21	Display line 1.2 small	Feedback	0	1654/0
0-22	Display line 1.3 small	Operating hours		1501
0-23	Display line 2 large	Frequency		1613
0-24	Display line 3 large	Cascade system status	Display text	2794/38
0-38	Display text 2	Follower (Backup master)		
1-00	Configuration mode	With feedback	Without feedback	3/0
1-20	Motor power	Nominal motor power in kW nameplate		
1-22	Motor voltage	Nominal motor voltage in volts on nameplate		
1-23	Motor frequency	Nominal motor frequency in Hz on nameplate		
1-24	Motor current	Nominal motor current in Amp. nameplate		
1-25	Motor speed	Nominal motor speed in rpm nameplate		
20-00	Feedback source 1	Analog input 54	N/A	2
20-12	Reference/feedback unit	bar	N/A	71
20-21	Setpoint 1	Enter working pressure	N/A	
20-93	PID prop. gain	2.0	N/A	
20-94	PID integration time	3 sec	N/A	
20-95	PID differentiation time	0.5 sec	N/A	
3-02	Minimum reference	Minimum sensor value, sensor reading	N/A	
3-0	Maximum reference	Maximum sensor value, sensor reading	= par 4-14	
3-15	Reference source 1	no function	No function	0
3-41	Disaster 1 start-up time	5 sec		
3-42	Ramp 1 delay time	5 sec		
4-12	Motor speed Low limit	Minimum frequency		
4-14	Motor speed High limit	Maximum frequency (50/60)		
5-10	Terminal 18 digital input	Start	Not in operation	8/0
5-11	Terminal 19 digital input	Not in operation		0
5-12	Terminal 27 digital input	Not in use		0
5-13	Terminal 29 digital input	Not in use		0
5-14	Terminal 32 digital input	Not in use		0
5-15	Terminal 33 digital input	Reset		1
6-00	Live zero timeout	10 sec	N/A	
6-01	Live zero function	Stop/trip	N/A	5
6-22	Terminal 54 Low voltage	0 mA (or 4)	N/A	
6-23	Terminal 54 High voltage	20 mA	N/A	
6-24	Terminal 54 low ref feedback.	Minimum sensor value, sensor reading	N/A	
6-25	Terminal 54 high ref feedback.	Maximum sensor value, sensor reading.	N/A	
6-27	Terminal 54 Live zero	On	N/A	1
6-50	Terminal 42 analog output	Speed 4-20 mA		137

PTO

Param.	Description	Setup 1	Setup 2	Code
8-01	Control site	Digital and ctrl.word		0
8-02	Control Source	none	FC Port	0/1
8-03	Control timeout time	60 sec	60 sec	
8-04	Control timeout function	Off	Off	0
8-30	Protocol	Multi Master Mode	Multi Master Mode	23
8-31	Address	1-X		
13-40.0	Logic Rule Boolean 1	Digital input DI27		35
13-41.0	Logic Rule Operator 1	NOT OR		6
13-90.0	Alert Trigger	Logic rule 0		26
13-91.0	Alert Action	Trip		12
13-92.0	Alert Text	Water temperature		
14-01	Switching frequency	Adjust in case of excessive motor noise		
14-20	Reset modes	2x auto reset		2
14-21	Automatic reset time	120 sec		
22-22	Low speed detection	enabled	N/A	1
22-23	No flow function	Sleep mode	N/A	1
22-24	Delay no flow	10 sec	N/A	
22-29	No flow at low speed frequency.	Frequency at which pump has no function	N/A	
22	Minimum running time	10 sec	Not applicable	
22-41	Minimum stop time	2 sec	N/A	
27-10	Cascade Controller	Master/Follower		1
27-11	Number of controllers	1...8		
27-21	Override limit	5% (see section 7.3 Adjustment aid for determining switch-on and switch-off values)	N/A	
27-23	Staging delay	30 sec	N/A	
27-24	Destaging delay	30 sec	N/A	
27-25	Override hold time	15 sec	N/A	
27-32.1	Stage on speed	48.0 Hz	N/A	
27-32.2	Stage on speed	49.0 Hz	N/A	
27-32.3	Stage on speed	49.5 Hz	N/A	
27-32	Stage on speed		
27-34.1	Stage off speed	Minimum frequency or > (35.0)	N/A	
27-34.2	Stage off speed	36.0 Hz	N/A	
27-34.3	Stage off speed	38.0 Hz	N/A	
27-34.4	Stage off speed	40.0 Hz	N/A	
27-34	Stage off speed		
27-52	Alternation time interval	Minutes before change, e.g., 1440	N/A	
1-29	Automatic adjustment (AMA)	Limited AMA / Full AMA with separate motor		2

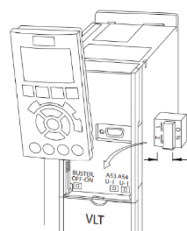

- Ensure that switch A54 is set to current (I), see image above.
- Ensure that the Bus termination switch is set to (on) on the last and **first** controllers, see image above.
- Connect shielded bus cable to 68 and 69.
- The 4-20 mA pressure sensor is connected to AI 2, on terminals 54 (-) and 12 (+).
- Æ Thermostat (NC) is connected to DI27, on terminals 27 and 13
- Connect reset to DI 33, on terminals 33 and 13
- PID control is started by connecting 18 (DI) to 12 (+24 V) on the master and master backup.

7.4.2 Settings for FC 202 (102) follower

Parameter	Description	Setting	Code
0-01	Language	Dutch	7
0-02	Engine speed unit	Hz	1
0-20	Display line 1.1 small	Motor current	1614
0-21	Display line 1.2 small	none	0
0-22	Display line 1.3 small	Operating hours	1501
0-23	Display line 2 large	Frequency	1613
0-24	Display line 3 large	Display text 2	38
0-38	Display text 2	Follower	
1-00	Configuration mode	Without feedback	0
1-20	Motor power	Nominal motor power in kW nameplate	
1-22	Motor voltage	Nominal motor voltage in volts on nameplate	
1-23	Motor frequency	Nominal motor frequency in Hz on nameplate	
1-24	Motor current	Nominal motor current in Amp. nameplate	
1-25	Motor speed	Nominal motor speed in rpm nameplate	
3-02	Minimum reference	0	
3-03	Maximum reference	= par 4-14	
3-15	Reference source 1	No function	0
3-41	Ramp 1 start-up time	5 sec	
3-42	Ramp 1 delay time	5 sec	
4-12	Motor speed low	Minimum frequency	
4-14	Motor speed high	Maximum frequency (50/60)	
5-10	Terminal 18 digital input	Not in operation	0
5-11	Terminal 19 digital input	Not in use	0
5-12	Terminal 27 digital input	Not in use	0
5-13	Terminal 29 digital input	Not in use	0
5-14	Terminal 32 digital input	Not in use	0
5-15	Terminal 33 digital input	Reset	1
6-50	Terminal 42 analog output	Speed 4-20 mA	137
8-01	Control Site	Digital and ctrl.word	0
8-02	Control Source	FC Port	1
8-03	Control timeout time	60 sec	
8-04	Control Timeout function	Off	2
8-30	Protocol	Modbus RTU	2
8-31	Address	2-X (Follow controllers always after masters)	
13-40.0	Logic Rule Boolean 1	Digital input DI27	35
13-41.0	Logic Rule Operator 1	NOT OR	6
13-90.0	Alert Trigger	Logic rule 0	26
13-91.0	Alert Action	Trip	12
13-92.0	Alert Text	Water temperature	
14-01	Switching frequency	Adjust in case of excessive motor noise	
14-20	Reset modes	2x auto reset	2
14-21	Automatic reset time	120 sec	
1-29	Auto adjustment (AMA)	Limited AMA / Full AMA with separate motor	2

- Ensure that the Bus termination switch is set to (on) on the **last** and first controller, see image above.

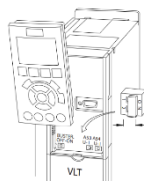

- Connect shielded bus cable to 68 and 69
- Æ Thermostat (NC) is connected to DI27, on terminals 27 and 13
- Connect reset to DI 33, on terminals 33 and 13

8 NOTES

The parameters mentioned in this booklet are only examples,
no rights can be derived from them.



Aartsdijkweg 23, 2676 LE Maasdijk, The Netherlands
+31 (0)174 51 50 50 · info@vanderendegroup.com · www.vanderendegroup.com