

PARKER LEVEL SWITCH JF-32

The dual sinker floater switch is used to control the level of liquids to prevent damage to a water system. This JF-32 floater switch is usable for saline solutions, corrosive liquids, clean water and waste water. The JF-32 floater switch is not applicable for oil, alcohol or fuels.

Specifications

	JF-32 floater switch
Voltage	250V AC
Current	10 A
Frequency	50 / 60 Hz
Usable control range	0,18 m – 10,0 m
Air pressure in water tank	1 Atmosphere
Usable temperature range	0 – 50°C
Rod material	Resin
Usable for following fluids:	<ul style="list-style-type: none"> - Clean water - Wastewater - Saline solution - Corrosive liquids
Content	<ul style="list-style-type: none"> - Relay box - 2 sinkers - 2,5 m rope

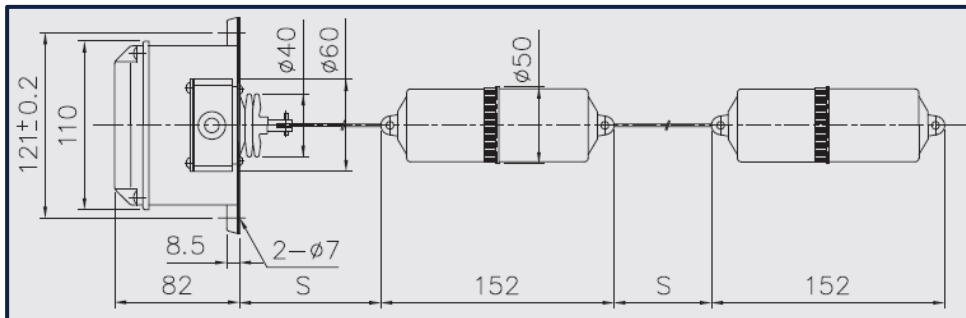
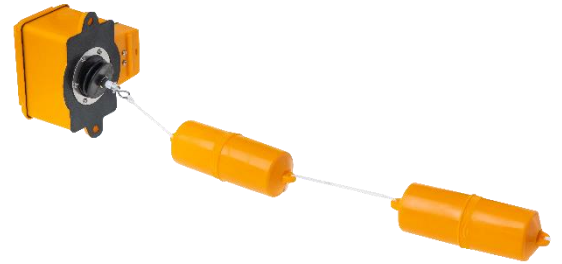

Mounting

Mount the floating switch as follow:

1. Make two mounting holes and the hole for the sinkers following Figure 1
2. Tie the two sinkers strongly to each other with the rope. Use the steps of Figure 2 for the prescribed knot.
3. Tie the sinkers to the designated ring at the bottom of the relay box.
4. Mount the relay box (with step 3 completed) to the tank with M6 bolts.
Note: packing is already on the relay box
5. Connect the floater switch following the connection diagrams in Figure 3 or Figure 4

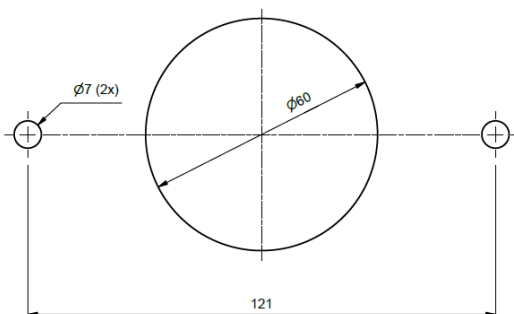

Figure 1 Mounting holes in supply tank

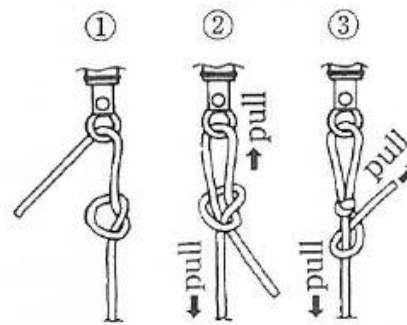

Figure 2 The prescribed knot

Connection diagram

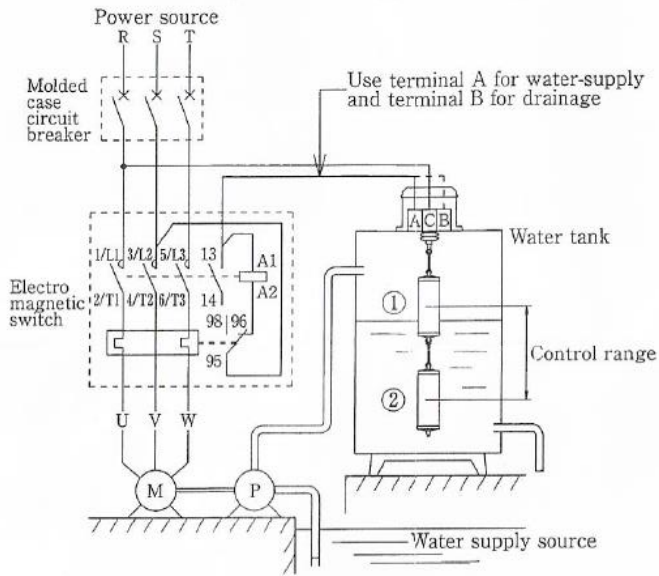

Figure 3 Connecting diagram normal use

Terminal A – water supply

Connect the power source to Terminal A to use the floater switch for water supply running. The system will work as follow:

- The pump will start when the water level reaches the center of the lower sinker.
- The pump will stop when the water level reaches the center of the upper sinker.

Terminal B - Drainage

Connect the power source to Terminal B to use the floater switch for drainage running. The system will work as follow:

- The pump will start when the water level reaches the center of the upper sinker.
- The pump will stop when the water level reaches the center of the lower sinker.

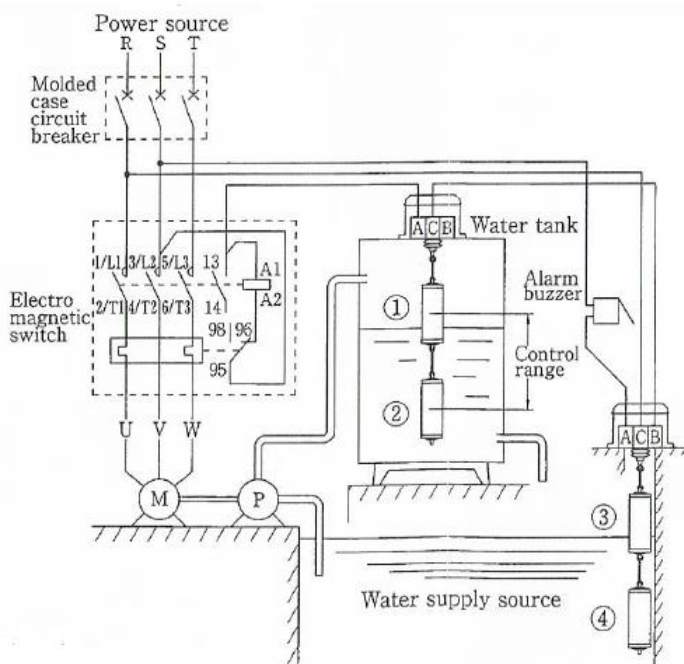

Figure 4 Connecting diagram with alarm

In case of using the floater switch in a water supply system, it is possible to install an alarm into the system. In this case, a second floater switch is needed. Use the connection diagram as shown on the left.