

# MANUAL

## Enmix Custom

### Low-speed agitator mixer



Version: 2023-06

## FOREWORD

This assembly manual is intended for use by technicians who are qualified to install this type of machine. It is not a user manual.

The Enmix has no real function when it is not connected to the appropriate facility for this installation and consequently it is classified as an unfinished machine. This assembly manual contains only those instructions pertinent to the safe assembly, correct installation and safe operation of the Enmix. It does not contain operating instructions for the entire installation. The approved installer should provide these.

Each chapter is numbered and, where appropriate, the chapters are divided into sections. The table of contents on page 3 gives an overview of the chapters and sections and a reference to the appropriate page number. There are numbers in the whole assembly manual referring to the parts described in chapter 1.1.3

# CONTENTS

Foreword .....	2
Contents .....	3
1 Identification .....	4
1.1 General .....	4
1.1.1 Description of the machine .....	4
1.1.2 Specifications.....	4
1.1.3 Schematic diagram of the machine.....	5
1.2 Operation.....	6
1.3 Use.....	7
1.4 Users .....	7
1.5 Media.....	7
1.6 Operating environment .....	7
1.7 Guarantee conditions .....	8
1.8 CE mark.....	8
1.9 Residual risks .....	8
2 Description.....	9
2.1 General .....	9
2.2 Operating principle .....	9
2.3 Transport and storage .....	9
2.4 Schematic structure of individual parts Enmix .....	10
3 Safety instructions .....	11
4 Assembly .....	12
4.1 Installation instructions .....	12
4.2 Delivery checklist.....	12
4.3 Assembly .....	13
4.4 Installation .....	14
4.5 Cable installation .....	14
4.6 Connecting / start-up.....	14
5 Operation.....	15
6 Maintenance.....	16
6.1 Regular checks .....	16
6.2 Oil .....	16
7 Malfunctions.....	16
8 CE Declaration of Conformity.....	17
9 UKCA Declaration of Conformity .....	18

## 1 IDENTIFICATION

This overview contains general information about the machine. The aim of this document is to define the purpose, the overall functioning and the application field of the machine.

### 1.1 General

#### 1.1.1 Description of the machine

The Enmix consists mainly of four components:

- A. Drive unit - an electric motor with a reduction gearbox
- B. Drip plate – for the event of oilspilling from the gearbox
- C. Frame - a custom-made stainless steel tubular frame
- D. Mixer - a long shaft with keyway and mixing blade, made entirely of stainless steel

Beside the main components of the Enmix there will be a shaft guide. This shaft guide will be included when the mixer shaft is longer than 1,0 meter.

The purpose of the machine is to keep liquids in motion in order to promote their dissolution and prevent precipitation. The relatively low rotational speed prevents foam formation. The Enmix drive unit must be mounted above a liquid reservoir such that the mixing blade will continue to rotate below the surface of the liquid up to the lowest liquid level.

Starting from April 2012, the Enmix is equipped with a drip plate for the event of oil spilling from the gearbox. This prevents oil from getting into the irrigation water.

#### 1.1.2 Specifications

Standard specifications Enmix	
Motor power	0,37 kW
Reduction ratio	15 : 1
Sealant	IP55
Capacitor*	12,5 or 20 µF
*Applied to 1 fase 230 Volt, by replacing check the value	
Material	Stainless steel 304 (optional: Stainless steel 316)

Engine specifications							
Frequency	Supply voltage	Current	Motor revolutions	Fase	Cos φ	Weight	No. VDEG
50 Hz*	230 V	2.0 A	1370 RPM	1F	0.96	6.2 Kg	53010001
50 Hz*	400 V	1.15 A	1410 RPM	3F	0.69	5.4 Kg	51021440
60 Hz**	440 – 480 V	1.15 A	1680 RPM	3F	0.69	5.4 Kg	51021440
60 Hz**	480 V	0.914 A	1715 RPM	3F	0.67	9.5 Kg	51021460
60 Hz**	575 – 600 V	0.715 A	1680 RPM	3F	0.72	8.0 Kg	53010050
*Deliver with 100 cm mixing blade							
**Deliver with 75 cm mixing blade							

Table 1 Specifications

Note: In special cases it is possible to adjust the direction of the rotation. If so, contact the manufacturer

### 1.1.3 Schematic diagram of the machine

Diagram of the main components

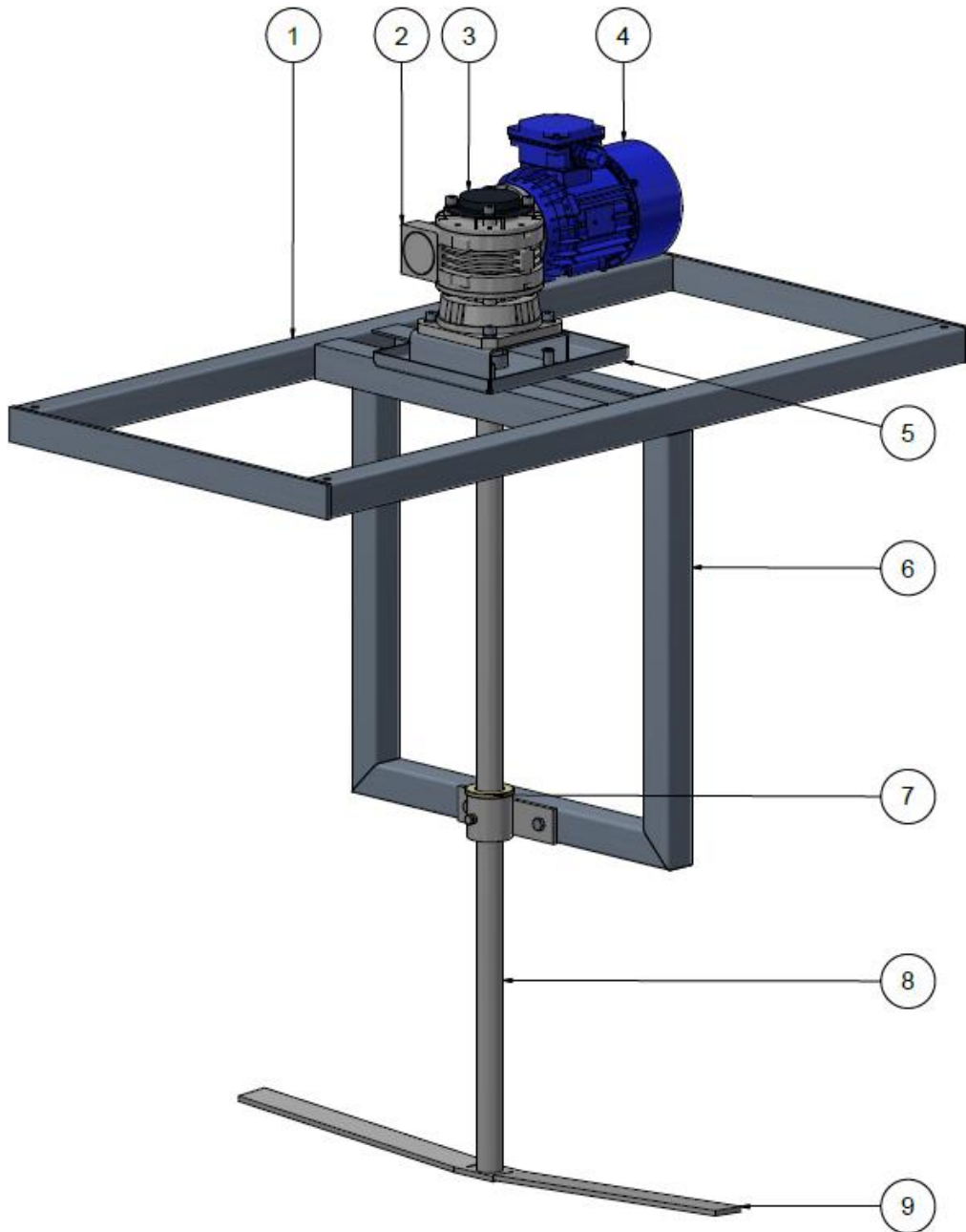

Figure 1 Schematic drawing of Enmix

No.	Description
1	Stainless steel frame
2	Reduction gearbox
3	Protection cap
4	Electric motor
5	Oil drip plate
6	Stainless steel frame for shaft guide
7	Sliding bearing for shaft guide (only when the mixer shaft is longer than 1,0 m)
8	Mixer shaft
9	Mixing blade

Table 2 Individual parts of the Enmix

## 1.2 Operation

The Enmix is supplied without controls. The Enmix 230 Vac version is supplied with locking thermal protection and with approximately two meters of cable. The Enmix must be connected to a switched socket outlet or a timer to operate the machine. The 400 Vac version does not include cable or thermal protection. These should be provided by the approved installer.

The 230 Vac version includes a reset button on the terminal connection box for the thermal protection device.



Figure 2 Location of the reset button

### **1.3 Use**

The Enmix is intended to be used for the mixing and continuous agitation of liquids containing additives. To achieve this, the Enmix must be placed above a liquid reservoir with the mixing blade (9) in the liquid.

In connection with the chemical resistance properties of the materials which make up the Enmix, the Enmix cannot and must not be used in just any medium. The manufacturer should be contacted for questions and advice in this matter. Upon request, the manufacturer can also provide a list of suitable and unsuitable chemicals.

Under no circumstances may the media contain long fibers (longer than 5mm), neither may viscous media (>1000 mPas) be mixed with the Enmix machine.

The supplier or the manufacturer should be contacted for advice on the use of media and the Enmix in general. Should the standard stainless steel type 304, of which the Enmix is composed, prove to be insufficiently resistant to certain media, the mixer shaft (8) and the mixing blade (9) are also available in stainless steel type 316.

The Enmix is not intended to be used without being placed on a liquid reservoir. The Enmix is not intended to be used for the purpose of processing foodstuffs.

### **1.4 Users**

Intended users are at least 18 years of age, employed by the company where the Enmix is installed and appointed by the management as the competent and qualified person to operate the Enmix.

Unintended users are users who do not meet the above requirements. Unintended users are all users who, by using the Enmix, create unsafe situations or cause danger to themselves and/or others.

### **1.5 Media**

Placing an image/comment in relation to the Enmix should always be discussed in advance with the producer/supplier. If this is not observed, any consequential damage can be recovered from this person/company.

### **1.6 Operating environment**

The Enmix is intended for use as a mixer on a liquid reservoir. When installing the mixer, care should be taken to ensure there is sufficient free space around the Enmix. The Enmix must be mounted on the liquid reservoir.

The Enmix is not intended for use in explosive surroundings.

## 1.7 Guarantee conditions

This product is guaranteed for a period of 6 months from the proven date of commissioning, with a maximum date of 2 years after the date of production. The proven date of commissioning means the date on which the machine was installed. If a claim is made on the guarantee, the parts in question must be submitted to the manufacturer for evaluation.

The guarantee will cease to be valid if one or more of the following conditions apply:

- Improper use or installation
- Repeatedly ignoring the advice of the manufacturer and/or the supplier
- Repair, maintenance or use by unauthorised persons
- Use of unsuitable connections with regard to power supply or cables
- Use of the machine in an unsuitable environment
- Intentional damage or adaptations to the machine

The guarantee conditions conform to the METAALUNIE CONDITIONS (the Dutch organization for small and medium-sized enterprises in the metal industry).

## 1.8 CE mark

The CE mark relates to compliance with the Machinery, Low Voltage, EMC and PED Directives. The Enmix is an unfinished machine and consequently does not meet all the conditions and essential safety requirements at the time of delivery. A list of the conditions and safety requirements that the Enmix does not meet at the time of delivery may be obtained from the manufacturer.

The CE mark can be found on the sticker affixed to the motor.

According to the Low Voltage Directive, the Enmix is classified as a Class I device.

## 1.9 Residual risks

It is practically and economically impossible to cover all risks for the full 100%. Furthermore, one of the risks of the machine may be closely connected to its functionality. The so-called residual risks are shown in the table below. It is important that the user is aware of the risks involved when using this machine. All safety regulations should be followed in order to minimize the risks as much as possible.

Risk page No.	Residual risk description	Risk factor	Category
1.	If the mixer is longer than the support legs, which may or may not be present, the Enmix cannot be placed in a stable position. This is only applicable prior to the installation of the Enmix.	1	A

*Table 3 List of residual risks*



## 2 DESCRIPTION

This chapter contains an explanatory description of the machine, which is the background information that is required to correctly and safely use the machine.

### 2.1 General

The rotation of the mixer shaft and the mixing blade sets the liquid in the reservoir in motion. The helical shape of the mixing blade not only rotates the liquid, it also pushes it upwards, or even downwards. The rotational direction (as seen from above) is normally clockwise.

The best rotational direction should be decided in each situation. In almost all cases, the standard rotational direction is sufficient, however, if the reservoir is relatively small and has reinforcement ribs, the rotational direction may have a positive impact on the performance. Prior to making any adjustments, please always contact the supplier.

### 2.2 Operating principle

The Enmix construction comprises a tubular frame (1). This frame is made to each customer's specifications, whereby the dimensions of the liquid reservoir in particular are the determining factor. The depth of the reservoir and the shape also greatly determine the construction. The frame is placed on, above or even in (to some extent) the liquid reservoir.

The material used is predominantly stainless steel tubing, type 304, 40x40mm. When working with low pH values (under pH4) or with other chemicals that could affect stainless steel type 304, stainless steel type 316 can be used for the mixer shaft and the mixing blade.

The reduction gearbox (2) of the motor (4) and the shaft guide (6) are mounted on the frame. The function of the shaft guide is to prevent buckling, vibration and oscillation of long mixer shafts (8). The shaft guide is only used when mixer shafts are longer than one meter or in special cases. The electric motor (4) is attached to the reduction gearbox (2) and has no additional support.

The mixing shaft runs through the shaft guide and into the hollow shaft of the reduction gearbox where it is attached via a key connection. The mixer shaft (8) is secured at the top by a bolt in an axial direction. A protection cap (3) is placed over the shaft to keep out coarse dirt and dust. The shaft guide (7) consists of a Teflon sleeve. A special bracket (6) is welded to the frame for the purpose of attaching the shaft guide. If no shaft guide is required, this bracket need not be affixed.

Since it concerns a 230 Vac electric motor with just one phase (as opposed to a three-phase motor), a capacitor is fitted. The 400Vac version is not fitted with a capacitor.

### 2.3 Transport and storage

The Enmix is not transported or stored in special packaging but delivered in parts and assembled at the end-user by an approved installer. When storing the Enmix, care must be taken not to allow the mixer shaft and, where appropriate, the shaft guide to bend.

## 2.4 Schematic structure of individual parts Enmix

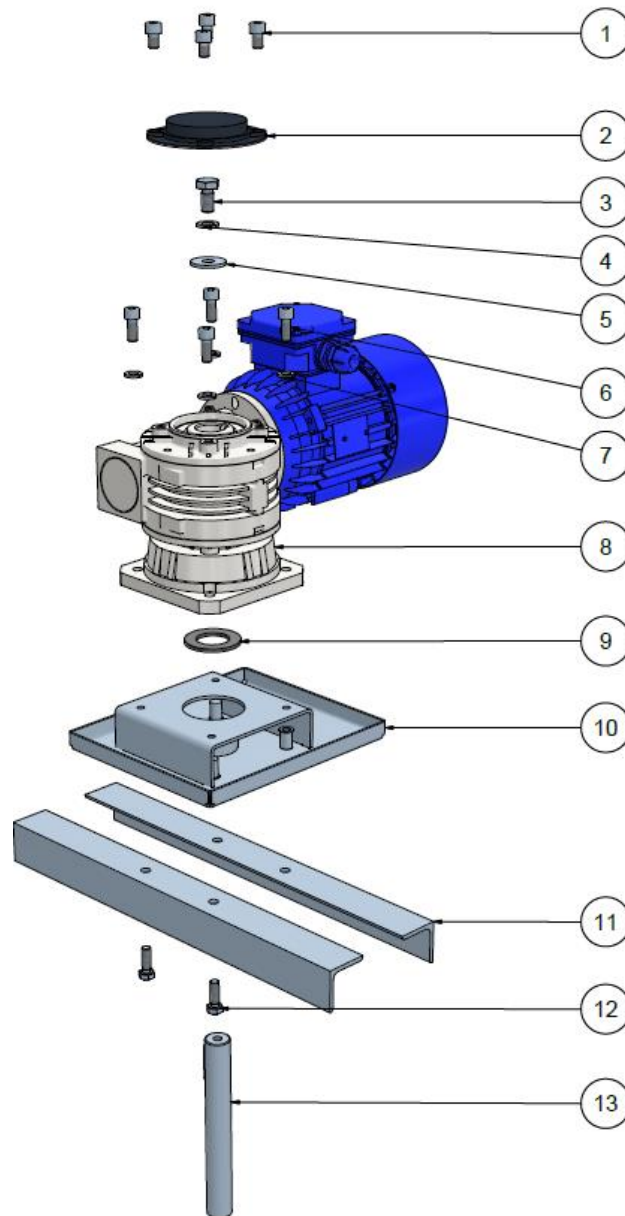

Figure 4 Overview drawing of individual parts Enmix.

No.	Part
1	Stainless steel socket head screw m8x12
2	PVC protection cap
3	Stainless steel bolt m10x20
4	Stainless steel spring washer m10
5	Stainless steel Fender washer m10
6	Stainless steel socket head screw m8x25
7	Stainless steel spring washer m8
8	Electric motor and Reduction gearbox
9	NBR rubber ring 50x30x3 mm
10	Oil drip plate
11	Stainless steel frame (frame in picture not complete)
12	Stainless steel bolt m8x25 + Stainless steel spring washer m8
13	Mixer shaft incl. sunk key 8x7x40 mm

### 3 SAFETY INSTRUCTIONS

Please read this assembly manual carefully and ensure that you observe the safety instructions before installing or using the Enmix.

The Enmix may only be used within the application areas for which it has been designed.

The Enmix has been designed to operate as a mixer for a system in which liquid media are used. These media may only contain chemical substances that are compatible with the materials of the Enmix components that come in contact with them. Further information on the application areas can be found under paragraphs 1.5, 1.6 and 1.7.

Work on the machine or installation of the electrical part of the Enmix may only be carried out by qualified personnel.

Make sure the power supply is connected to a final circuit with an earth connection with a maximum fuse value of 16A and a circuit breaker with residual current of 30mA.

Add solids gradually to prevent blockage of the mixing blades.

Always follow all assembly and safety instructions. Failure to observe these instructions may cause serious damage to persons or property.





Safety symbol	Description
	Automatic starting machine!
	Electric voltage present!
	Hot surface!
	Rotating parts!
	Reading instructions obligated!

Table 4: Safety instructions Enmix

## 4 ASSEMBLY

The Enmix is an unfinished product, and consequently the manufacturer cannot install all the required safety devices such as control logic or an emergency stop. It is, therefore, important that the approved installer takes care of these requirements.

### 4.1 Installation instructions

Please make sure that the Enmix is out of reach of children at all times.

Advice with regard to dosage rates and types of fertilizer should be obtained from your supplier.

- Place the Enmix on a flat, stable surface.
- Make sure that the Enmix is firmly attached to the fertilizer bin.
- Make sure at all times that the mixing blade (9) can rotate freely.
- Make sure that contact with the agitator-mixer is prevented by placing a safety grid or lid on the fertilizer bin.
- If the Enmix is delivered without a frame, the electric motor (4) should be attached to the bin in accordance with the instructions of the bin supplier. Assembly of the mixer shaft to the motor remains defined in accordance with the procedure below.

Please note that mixer shafts longer than one meter must be supported!

During each phase of the assembly the approved installer or the user must ensure that he or she can work safely. The use of a stepladder or the helping hand of an extra person or persons will make assembly of the machine easier and safer.

### 4.2 Delivery checklist

Make certain that all components have been delivered prior to commencing assembly. The components that make up the Enmix will be delivered as follows:

- Frame:
  - Stainless steel frame (1) (synthetic shaft guide optional)
  - Oil drip plate with mountings (5), mounted on the frame
  - Electric motor (4), mounted onto the frame
  - +/- 2 metres of cable with plug attached to the electric motor
- Or
  - Electric motor (4), delivered separately
  - Oil drip plate (5) with mountings
  - +/- 2 metres of cable with plug attached to the electric motor
- Mixer shaft:
  - Stainless steel mixer shaft (8) with mixer blade (9)
  - Sunk key at the top of the keyway in the mixer shaft (8)
  - Yellow protection cap, over the sunk key and the end of the mixer shaft
  - Lock bolt screwed into the yellow protection cap at the end of the mixer shaft
  - Compression ring and washer under the lock bolt
  - NBR rubber ring (50x30x3)
- Manual, in a resealable plastic bag attached to the frame
- Protection cap (3), together with the manual in a resealable plastic bag attached to the frame

## 4.3 Assembly

The Enmix must be assembled following the steps mentioned below. If these steps are not followed properly, parts could be damaged or the system will not work as prescribed. For the assembly, see Figure 3

- Place the frame on its side and ensure stability of the frame;
- Have the lock bolt of the mixer shaft ready. Consisting of one Stainless steel bolt m10x20 (3), one Stainless steel spring washer m10 (4) and one fender washer m10 (5).
- Assemble the drive unit onto the frame of the mixing bin (in case the drive unit is delivered separately);
- Remove the protection cap from the mixer. **Attention, do not lose the sunk key!**; if the key has fallen out of the shaft, place it back in the groove. use a synthetic or a wooden hammer only!;
- Slide the mixer shaft (9) through the shaft guide (only with mixer shafts longer than 1m)
  - the shaft guide is made of self-lubricating synthetic material. Usage of;
- Place the NBR rubber ring (7) between the motor mount and oil dripping plate (8) and slide the mixer shaft (9) through the NBR rubber ring (7)
- Slide the mixer shaft (9) into the hollow shaft of the reduction gearbox (6) if necessary, use a little grease to assemble the shaft
- Screw the Stainless steel bolt m10x20 (3), Stainless steel spring washer m10 (4) and fender washer m10 (5) into the top of the shaft (9);
- Place the PVC protection cap (2) on the reduction gearbox (6). Use four Stainless steel socket head screws m8x12 (1).
- The Enmix is now ready to be mounted onto the liquid reservoir

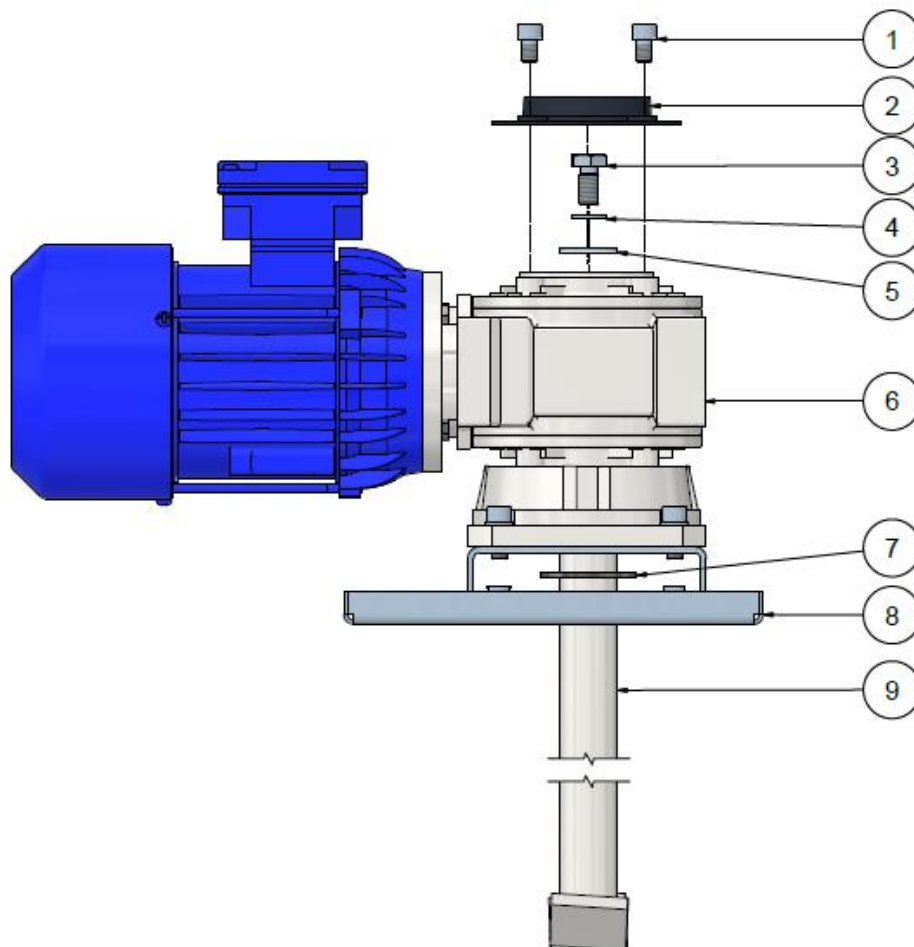

Figure 3: Assembly of mixer shaft into the drive

## 4.4 Installation

- Select a suitable location for the Enmix:
  - ensure the mixing blade can rotate freely
  - ensure the mixing blade rotates +/- 8 cm from the bottom of the reservoir
  - ensure there is sufficient space around the Enmix
  - ensure there is a socket outlet within a maximum range of 2 metres from the Enmix
  - ensure the Enmix is within view of the socket outlet
- Prepare for installation:
  - consider where to place the Enmix
  - make the necessary arrangements to mount the Enmix onto the reservoir
    - use the pre-drilled holes in the frame to mount the Enmix
  - in round reservoirs the water sometimes turns and swirls in one direction instead of mixing. In consultation with the manufacturer, place a dividing plate in the reservoir to prevent this from happening
  - ensure the Enmix can be mounted safely onto the reservoir
    - request assistance and use practical aids such as a stepladder or a footstool
- Mount the Enmix onto the reservoir
- **Make sure the mixer is fitted with a safety guard and poses no danger to people!**
  - use a cover or grid or any other appropriate guard

## 4.5 Cable installation

Connecting the wires into the control cabinet must be done in the prescribed way.

**Make sure there is no voltage present!**

The cable exist out of 5 wires. These wires are connected into the electric motor to the following parts

- L1 = U1
- L2 = V2
- L3 = W3
- L4+L5 = Thermostatic switch

## 4.6 Connecting / start-up

- Check that the Enmix is securely mounted
- Check that the motor (4) and reduction gearbox (2) are firmly attached to the frame
- Check that the mixing blade (8) can rotate freely
  - make sure there are no obstacles in the way of the mixing blade
- Check that the mixer has a safety guard and poses no danger to people
- Insert the plug in the socket
  - the Enmix must be within view of the socket outlet
  - the socket outlet must have an earth connection
  - a switched socket outlet is highly recommended
- Check the rotational direction. The standard direction, viewed from above, is clockwise
  - the rotational direction of the mixing blade is indicated on a sticker affixed to the gearbox
  - the electric motor, viewed from behind, should rotate in a clockwise direction

Note: In most cases, it is not necessary to continue stirring. Operating the Enmix with a timer and/or low water circuit is recommended. This will prevent unnecessary turning and will significantly increase the lifespan of the machine.

## 5 OPERATION

Use the Enmix to dissolve chemical agents in water. Do not dissolve long fibers (longer than 5mm) or viscous agents (viscosity > 1000 MPas) with the Enmix.

Always make sure that the agents and liquids used are suitable for use in the Enmix. The supplier or manufacturer should be able to send you a list, free of charge, containing a complete overview of the agents that may or may not be used.

The Enmix may be used for acids to a minimum level of pH4.

## 6 MAINTENANCE

The Enmix is practically maintenance free. It is recommended to check the installation each month and to report any defects to the supplier or the manufacturer.

Always disconnect the power supply before performing any maintenance work on the Enmix. The plug should be removed from the socket outlet when working on the 230 Vac version. On the 400 Vac version the power supply should be disconnected and secured.

### 6.1 Regular checks

Frequency: monthly

- Check that the frame (1) is still firmly attached to the reservoir
- Check that the motor (4) and reduction gearbox (2) are still firmly attached to the frame
- Check that the lock bolt is still firmly in place
  - remove the PVC protection cap from the mixer shaft
  - check the lock bolt and, if necessary, tighten it again
  - replace the cap
- Check that the mixer blade (9) can rotate freely
- Check that the mixer shaft (8) is straight
- Check that the oil in the reduction gearbox is ok, see chapter

### 6.2 Oil

It's recommended to refresh/ change the oil, which is applied into the reduction gearbox (2), every 5 years. See Table 5 for the specifications of the oil to be used.

Oil reduction gearbox		Article No. VDEG
Shell Cassida Fluid	GL 460 NON TOX	97003470

Table 5 Specifications of the oil into the reduction gearbox

When it is found that there is oil on the oil drip plate(5) under the gearbox (2), the Enmix must be checked extra. If the problem cannot be found or oil continues to leak, contact the supplier.

## 7 MALFUNCTIONS

Below is a table of possible malfunctions and their cause. Always make sure that the power supply is disconnected prior to carrying out any repair work to the Enmix.

Problem	Cause	Solution
The mixer no longer turns	No power	Check power supply
	Thermal protection is switched off	Remove any large parts in the fertilizer bin and press the thermal protection reset button
	Condenser is broken	Replace condenser
Thermal protection switches off repeatedly	Too much dirt on the mixing blade	Remove large parts and press the thermal protection reset button
	Guide is dirty	Remove shaft from the guide and clean the guide
	Shaft is bent	Contact your supplier
Motor works but mixer does not	Reduction gearbox broken	Contact your supplier

Table 6: Malfunctions and solutions



## 8 CE DECLARATION OF CONFORMITY

### EC-DECLARATION OF CONFORMITY

(according to Annex II B of the Machinery Directive 2006/42/EG)

We, Van der Ende Pompen  
Aartsdijkweg 23  
2676 LE Maasdijk  
The Netherlands

declare under our sole responsibility that the machine:

Enmix agitator-mixer

to which this declaration relates, complies with all the provisions of the following Directives:

Machinery Directive	2006/42/EG
Low Voltage Directive	2006/95/EG
EMC Directive	2004/108/EG

and (where applicable) complies with the following standards or other normative documents:

The Netherlands  
Maasdijk  
20 January 2020

L. van der Ende



## 9 UKCA DECLARATION OF CONFORMITY

### UKCA-DECLARATION OF CONFORMITY

We, Van der Ende Pompen  
Aartsdijkweg 23  
2676 LE Maasdijk  
The Netherlands

declare under our sole responsibility that the machine:

Enmix agitator-mixer

to which this declaration relates, complies with all the provisions of the following Directives and their amendments:

Supply of Machinery (Safety) Regulations	2008:1597
Electrical Equipment (Safety) Regulations	2016:1101
Electro Magnetic Compatibility Regulations	2016:1091

and (where applicable) complies with the following standards or other normative documents:

not applicable

The Netherlands  
Maasdijk  
20 January 2020

L. van der Ende







Aartsdijkweg 23, 2676 LE Maasdijk, The Netherlands  
+31 174 51 50 50 · [info@vanderendegroup.com](mailto:info@vanderendegroup.com) · [www.vanderendegroup.com](http://www.vanderendegroup.com)