

AIRMIX

controlled ventilation/circulation system



Horticultural fans

The Airmix system is designed to create an optimum growth climate. The Airmix has modulating valves to ensure that the right mixture of warm and cold air is blown into the greenhouse. This makes it possible to provide ventilation and dehumidification with closed screens. The Airmix also works as a horizontal circulation system and is therefore multifunctional. This enables the system to provide 'controlled' ventilation, and means that, under cold weather conditions, it is no longer necessary to create a gap in the screen to allow moisture and/or heat to be discharged outside. Creating a gap in the screen can cause considerable differences in temperature and will also result in a substantial loss of energy.

The Airmix is equipped with the same sort of fan that is used in horizontal circulation systems. A suction unit with valves is attached to the input section of the fan. This enables the air to be drawn in from below as well as above the screen. When the valves are closed, the Airmix draws in air from beneath the screen, operating just as a conventional horizontal circulation system does. When the valves are open, the fan does not draw air out of the greenhouse itself, but from the area above the screen. This way, the Airmix functions as a ventilation system. The system can be applied to all types of screening systems.

What makes this system so unique is the fact that the valves can be controlled by a climate computer, ensuring precisely the right amount of air beneath as well as above the screen. The system also allows air from above to be mixed with air from below. The greatest added value lies in the fact that all of this can be done with a fully closed screen, to create an optimum climate while saving energy.

Climate

The amount of air drawn in from above the screen by the valves has no adverse effect on the horizontal circulation of air. Cold air from above the screen is quickly warmed up the greenhouse's own heat buffer at the top of the greenhouse. As a result, the crop will not be affected by this air blown into the greenhouse.

Ventilation capacity

The ventilation capacity needed to discharge moisture and/or heat depends on the amount of moisture produced by the crop, or the heat discharged by the lighting system.

Of course, this varies from crop to crop, and depends on the cultivation method used. Once the desired amount of $\text{m}^3/\text{m}^2/\text{hr}$ is calculated, the necessary Airmix capacity in terms of ventilation and/or dehumidification could be installed. When growing roses, for example, the required capacity would be approximately $20 \text{ m}^3/\text{m}^2/\text{h}$, with one Airmix per 250 m^2 .



An entirely different example to take into consideration would be a crop that requires a ventilation capacity of approximately 5 m³/m²/hr. In a situation like this, one Airmix would be installed for every 1000 m². However, this would result in insufficient ventilator capacity for adequate horizontal circulation. The solution would, in this case, be to install horizontal fans in between the Airmixes. For more information about capacity contact sales@vanderendegroup.com.

Valve operation

To ensure that the right amount of air is drawn in from above the screen, the valves need to be controlled by a climate computer. There are various options available: controlling at relative humidity, moisture drainage or greenhouse temperature. In this case, the temperature above the screen would also need to be measured; if this becomes too high it will reduce the activity of the Airmix. Temperature measurements above the screen should ensure the correct ventilation window angle to allow excess moisture and/or warm air to be discharged outside. We recommend discussing all the available options with your climate computer supplier.

Assembly model T

The Airmix model T is mounted onto the underside of a trellis profile, similarly to horizontal fans. Mounted this way, the Airmix can, at all times, continue to operate as a horizontal circulation system. To ensure that the Airmix is properly suspended vertically, a cable is laid from the underside of the Airmix to the next trellis profile. If you have only one screen mounted at the bottom duct of the trellis profile, a standard Airmix will be sufficient. If you have only one screen mounted at the top duct of the trellis profile, an extension duct will be attached to the Airmix. If you have a double screen on a single wire bed, the Airmix can be installed as described above.

If you have a double screen on two wire beds, a separate extension duct will be mounted in between the screens with sealing brushes that will enable the screen frame to be pulled through from in between the Airmix and the extension duct.

To allow the Airmix to draw in air from above the screen, adjustments to the screen system will be needed. A hole will need to be made in the screen directly above the Airmix. This needs to be done in such a way that, when the screen is completely closed, the Airmix will be located immediately underneath this hole. The Airmix has been built in such a way that it can always be mounted on the correct side of the trellis profile. The hole in the screen fabric should be rectangular in shape and its edges reinforced with a triple seam and double-sided tape. For further instructions, please contact our specialists via sales@vanderendegroup.com.

Assembly model G

The Airmix model G is mounted on an aluminium gutter. This gutter is mounted between the truss. For a single installation two gutter profiles are required, for a multiple screen installation this number is multiplied. By using these gutters it is not necessary to make and finish a hole in the screen.

The image on the next page shows a cross section of the required screen adjustment for Airmix model G in a double screen installation. With the aluminium mounting profile of the Airmix, a fabric hanger is made. This is similar to the fabric hanger on the facade of a greenhouse. In a situation with double screen fabric, the bottom aluminium screen profile is crossed out. In a single screen installation the aluminium profile can remain in one piece.



model T

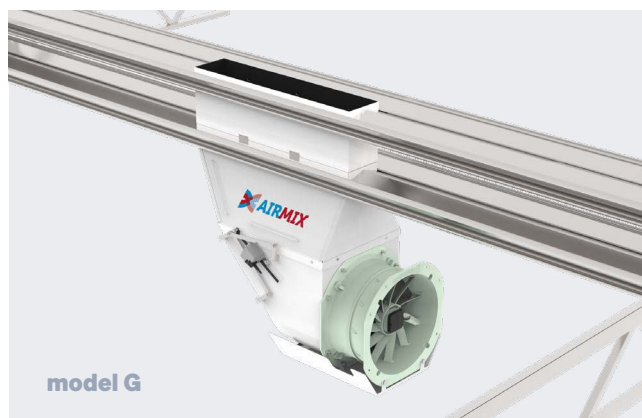

model G

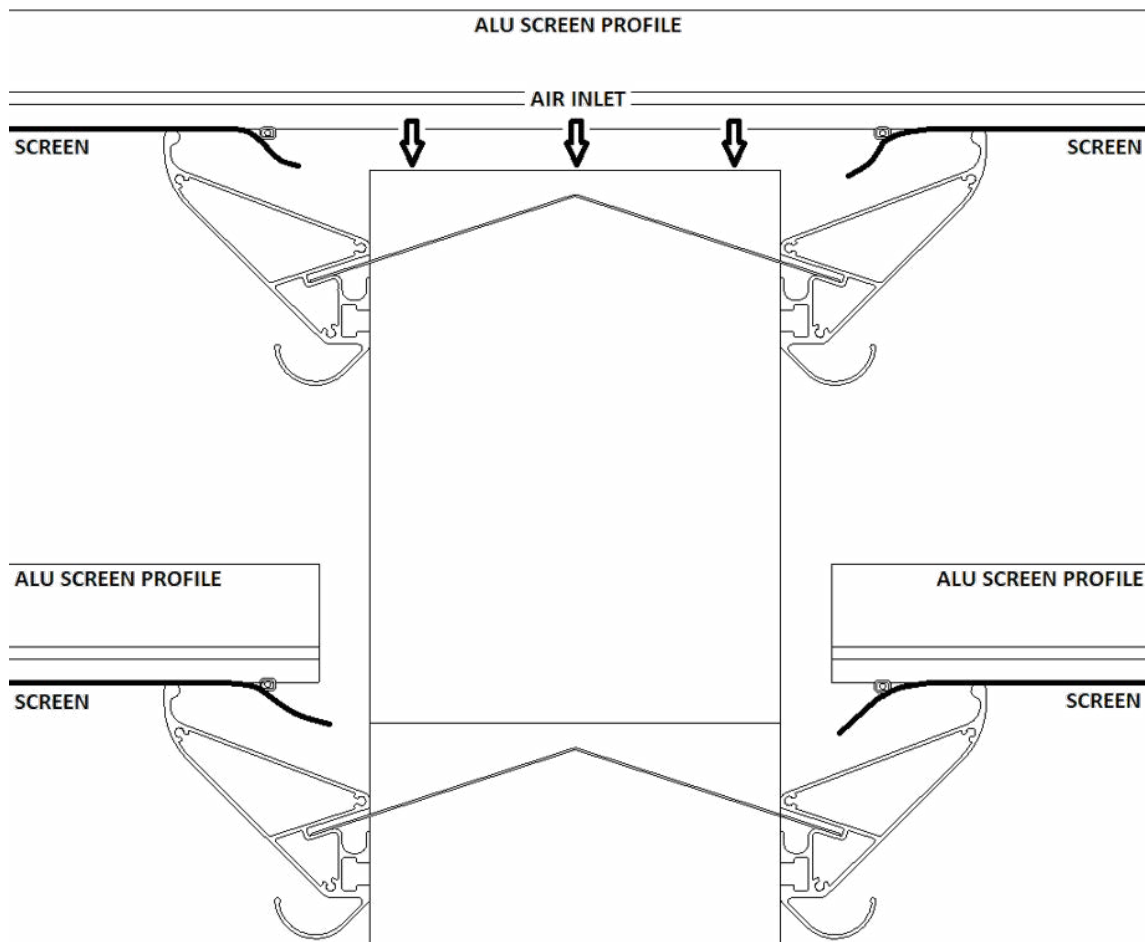

Discharge of the drawn-in air

If a great deal of air is drawn in, this will result in overpressure beneath the screen. A slight overpressure is beneficial for a uniform temperature, but if the overpressure becomes too great this will reduce the Airmix capacity. The overpressure created depends on the installed ventilation capacity, the permeability of the screen fabric and the extent to which the greenhouse itself 'leaks' air. If the overpressure becomes too great, measures will need to be taken to reduce this.

The Airmix system is patented.

How the Airmix operates





GENERAL			
TYPE	Airmix model T and model G		
FAN			
	50 Hz AC	60 Hz EC	60 Hz AC
Power	0,38 kW	0,42 kW	0,24 kW
Voltage	230 V	200 - 277 V	230 V
Rotation speed	1250 rpm	1470 rpm**	960 rpm
Current	1,7 A	2,1 - 1,5 A	1,05 A
Circulation capacity	5800 m ³ /h*	5800 m ³ /h**	5060 m ³ /h*
Ventilation capacity	5200 m ³ /h*	5200 m ³ /h**	4400 m ³ /h*
Dust and water ingress protection	IP54		
Isulation class	THCL 155		
Material fan housing	Plastic high quality composite		
Power cord	5 m cord plus Type F earthed plug	None	None
Certification	CE-mark, EAC	CE-mark, EAC, cURus (E347018 ZB-155)	CE-mark, EAC, cURus (E111399 ZB-155)
LINEAIR DRIVE			
Power	1,5 W		
Voltage	24 V AC 50/60Hz 24 V DC		
Functional range	AC/DC 19.2 .. 28.8 V		
Duration	116 sec		
Dust and water ingress	IP54		
Adjustment force	150 N		
Power cord	5 m cable 3 × 0.75 mm ² without plug		
Certification	CE-mark, cULus (E108966)		
HOUSING			
Material	Aluminium		
Number of valves	Model T: 2 pc.	Model G: 3 pc.	

* Measured without air guide plate and grille, and depending on pressure difference.

** The EC fan has a nominal rotational speed of 1470 rpm. A rotational speed of 1250 rpm gives a ventilation capacity of 5200 m³/hour. The installation drawings and calculations are based on this rotational speed and ventilation capacity as standard. The EC fan is a fan with internal control. The EC fan is supplied as standard on the basis of factory settings and non-addressed.

Optional

- o Separate extension duct
Needed when a single or double screen is mounted to the top and bottom duct of the beam.
- o Fixed extension duct (model T)
Needed when a single or double screen is mounted to the upper duct of a beam.
- o Air guide plate
The direction of the air flow can be controlled with an guide plate.
- o Valve position measuring device
Needed to relay the valve position to the climate computer.
- o Extended suspension bracket (model T)
This ensures that the Airmix hangs further from the truss to create space between the Airmix and the truss.
- o Discharge grille

Technical drawings

Airmix model T

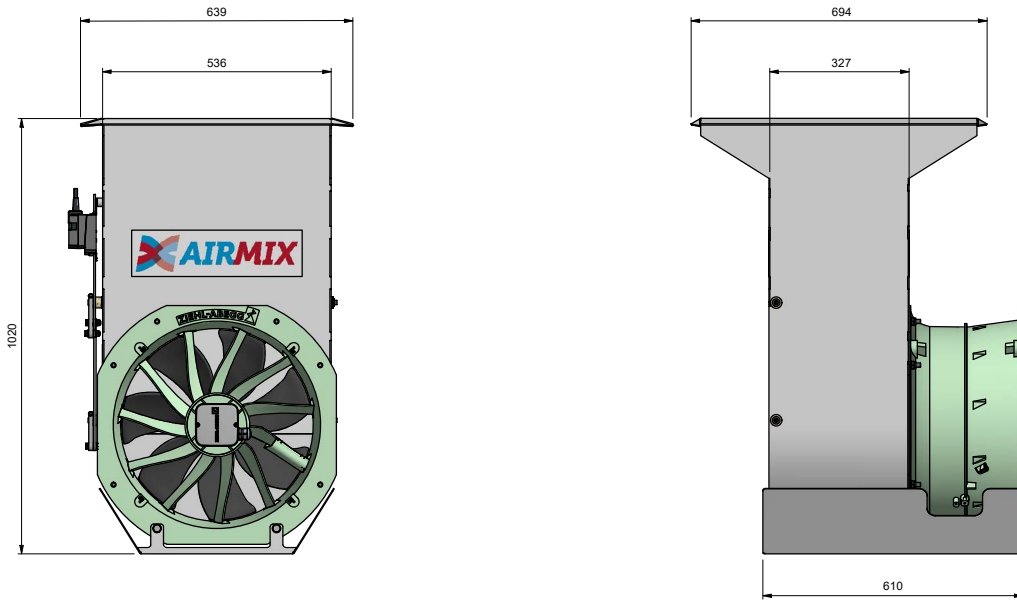

Airmix model G

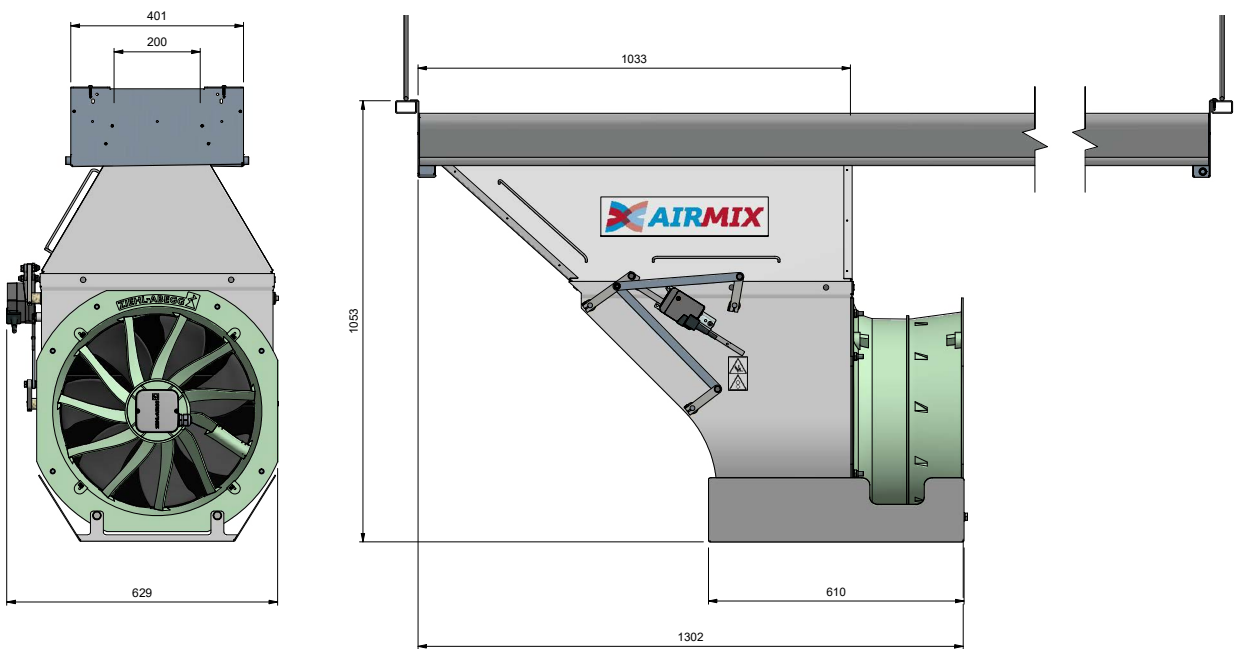

Example Airmix trial in vegetables grown without artificial lighting

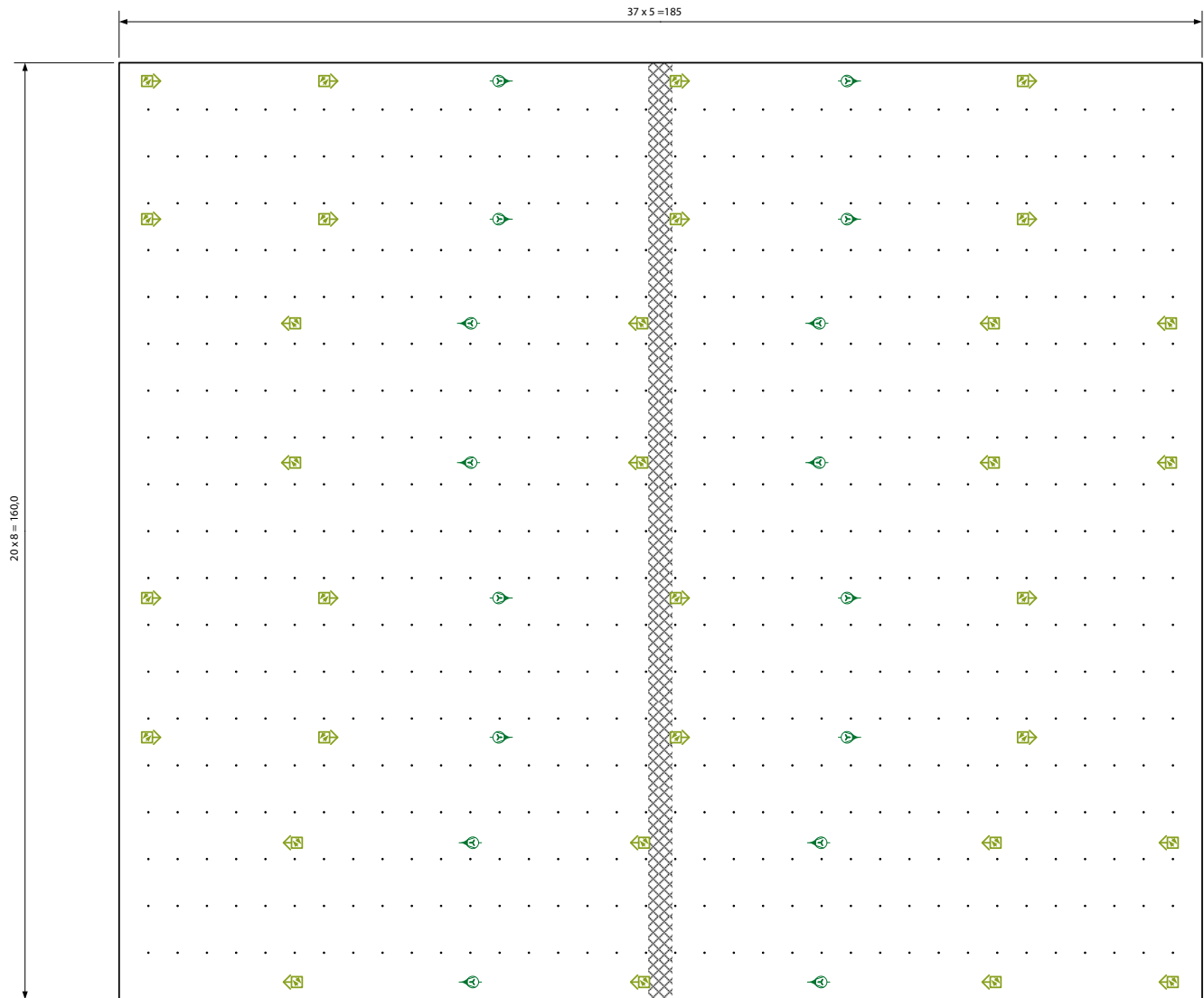

Example:

Surface area : 29.600 m²

Enfan : 16 pcs

Airmix : 32 pcs

Ventilation capacity : 5,4 m³/h per m²



Airmix



Enfan