

FUNDATIEPLAN
FOUNDATION PLAN

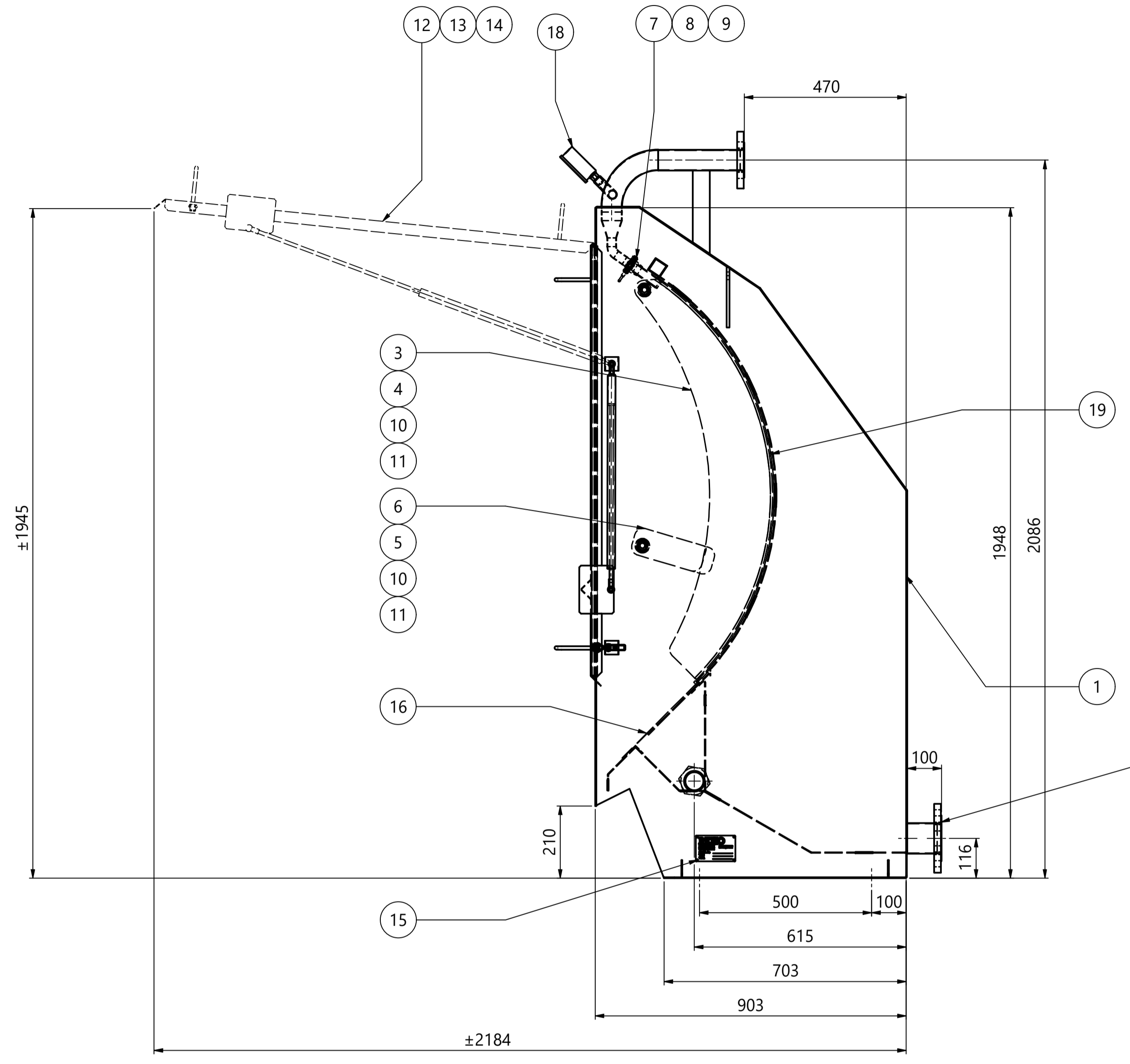

FLENZEN : GECOAT ALUMINIUM
FLANGES : COATED ALUMINIUM

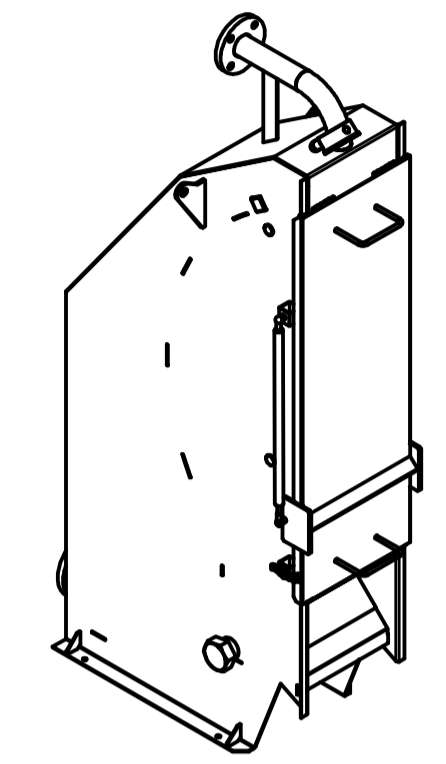

19	1	DT0300-ZE		ZEEFPLAAT
18	1		AISI 304	MANOMETER 1/2" (O) 100mm 0-6bar
17	1		PVC	CAP 2"
16	1	DT0300-O	AISI 304	ONTWATERINGSPLAAT SW=0,50
15	1	2REKKIG49-2	AISI 316	TYPE PLAAT
14	2	ROD500SC0250		GASDRUKVEER 10/22 500MM 250N
13	2	2REKE101119	EPDM	AFDICHTING 1011-19 L=1500
12	1	DT0300-C		VOORDEKSEL 300DT
11	4		A2	ZESKANTTAPBOUT M16x20 DIN933
10	4		A4	RING NF E 25-514 - L16 - 160 HV
9	1	2REKMON0201	AISI 304	TC KLEMBAND LICHT 50,5
8	1	DT0000-NA		VOEDINGSNOZZLE Ø20 (3/4")
7	1	2REKMON0203	SILICONE	TC AFDICHTING DIN DN40/50,5
6	1	DFZ0000-ZC	PP GRIJS	BLOKKEERSEGMENT RECHTS
5	1	DFZ0000-ZB	PP GRIJS	BLOKKEERSEGMENT LINKS
4	2	2CCDFZ00075	SILICONE	AANDRUKRUBBER 10x6
3	2	DT0000-ZA	PP GRIJS	AANDRUKSEGMENT
1	1	DT0300-2A	AISI 304	CASCO 300DT
ITEM	QTY	PART NUMBER	MATERIAL	DESCRIPTION

TITLE: ZEEFBOCHT/SCREEN 300DT		SCALE: 1:10	A1		
MATERIAL:		MASS: 148,03 kg			
 REKO Industrial Equipment BV The Netherlands www.reko.com	REV 4	Released	22-03-21	SK	DRAWING NUMBER DT0300-2
	REV 5	Released	17-06-21	SK	
	REV 6	Released	08-07-21	SK	
	REV 7	Released	08-07-21	SK	

GEN. DIM. TOLERANCES ACC. TO ISO 2768-mk
WELDING TOLERANCES ACC. TO ISO 13920-AE
SHARP EDGES REMOVED ACC. TO ISO 13715

© THIS DRAWING IS ISSUED BY REKO INDUSTRIAL EQUIPMENT BV SUBJECT TO THE CONDITIONS THAT IT IS NOT COPIED EITHER IN WHOLE OR IN PART OR DISCLOSED TO THIRD PARTIES UNLESS PRIOR WRITTEN AUTHORISATION IS GIVEN BY REKO INDUSTRIAL EQUIPMENT BV

DN150 PN10
EN1092-1 T02

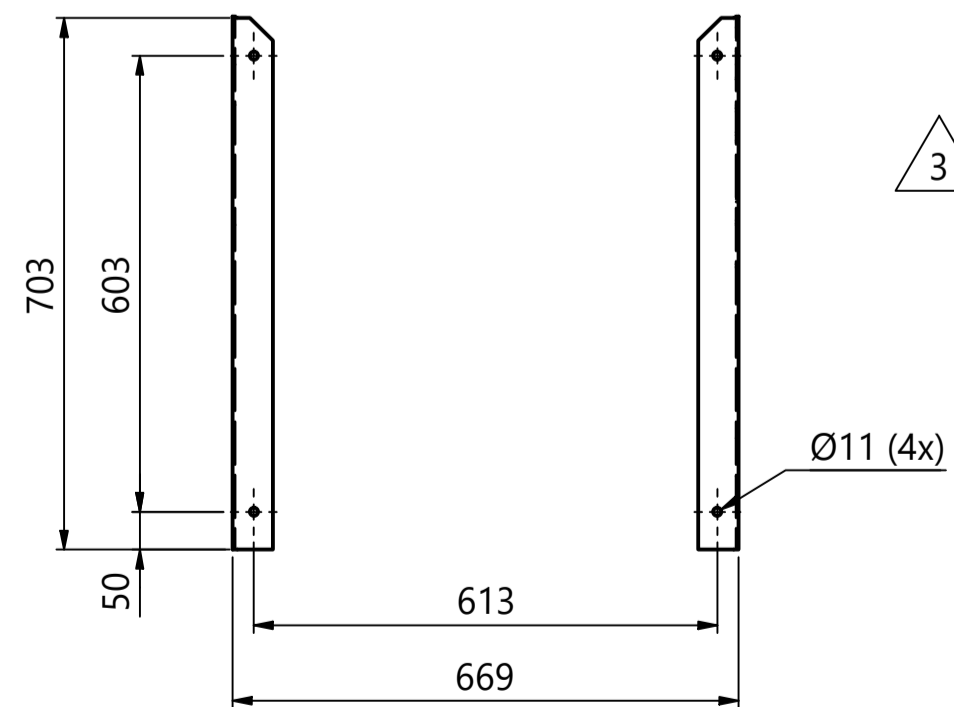
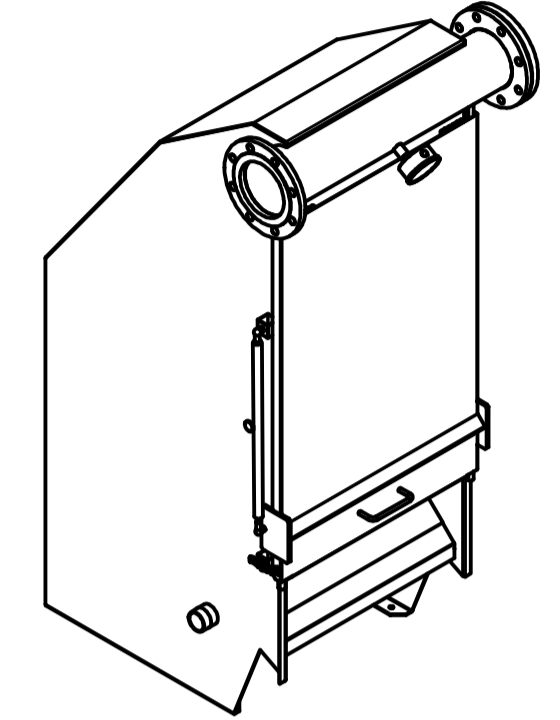
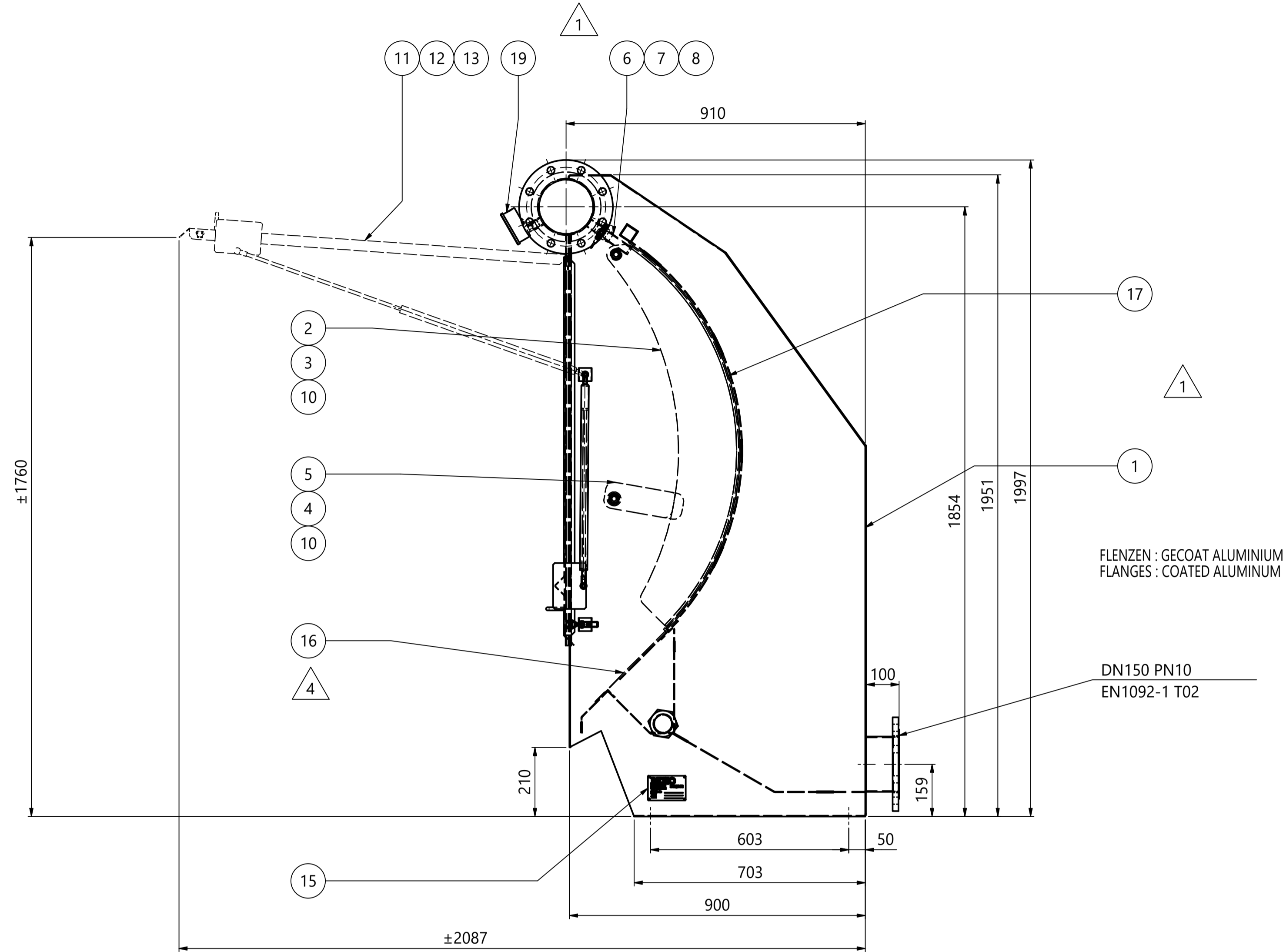
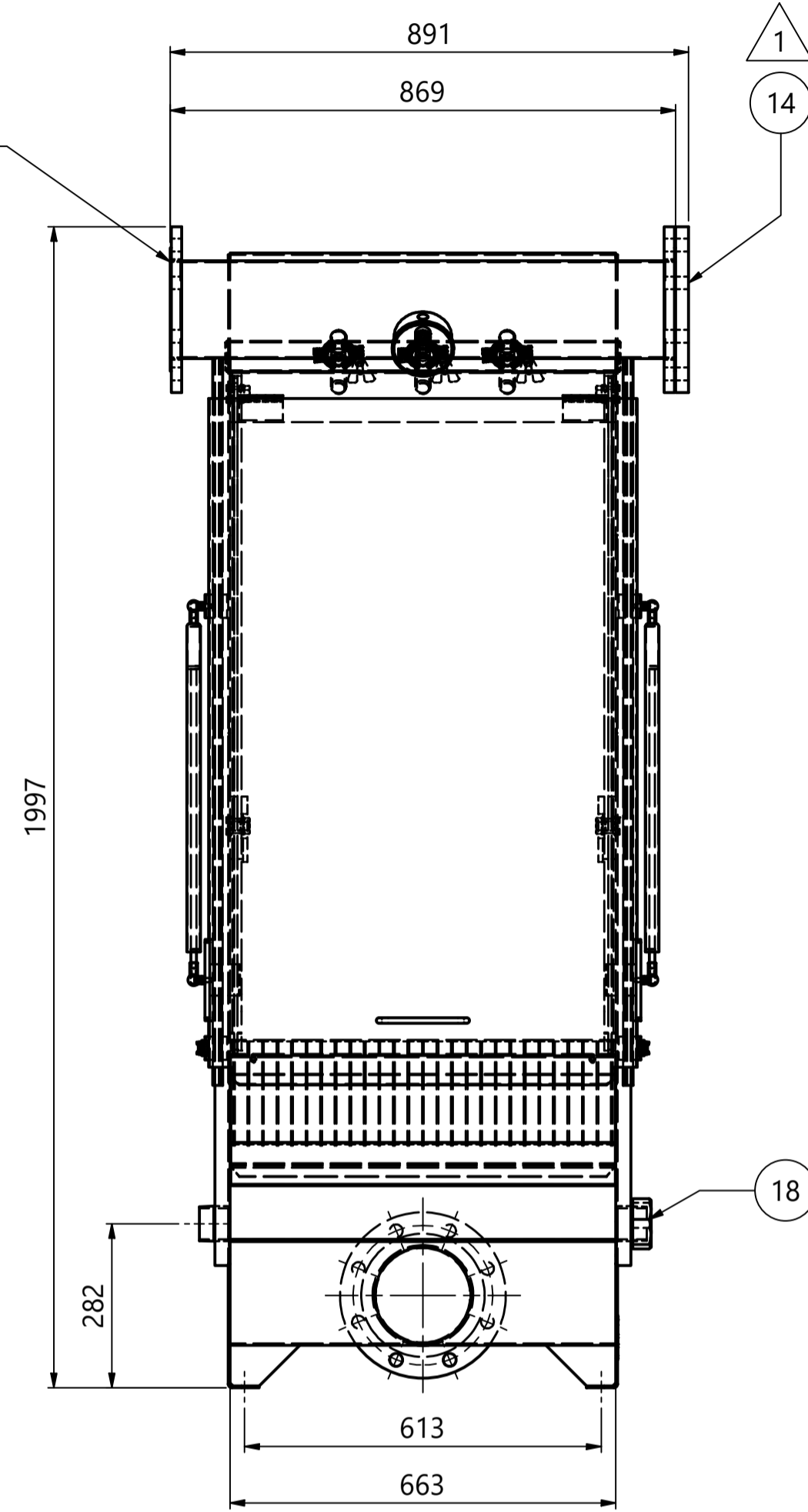

FUNDATIEPLAN
FOUNDATION PLAN

20	4		A2	VLAKKE SLUITRING M16 DIN125
19	1		AISI 304	MANOMETER 1/2" (A) 100mm 0-6bar
18	1		PVC	CAP 2"
17	1	DT0600-ZE	AISI 316 (WW)	ZEEFPLAAT 300DT
16	1	DT0600-O	AISI 304	ONTWATERINGSPLAAT
15	1	2REKKIG49-2	AISI 316	TYPE PLAAT
14	1		AISI 304	BLINDFLENS DN150 PN10 EN1092-1 T05
13	2	ROD500SC0350		GASDRUKVEER 10/22 500MM 350N
12	2	2REKE101119	EPDM	AFDICHTING 1011-19 L=1500
11	1	DT0600-C		VOORDEKSEL 600DT
10	4		A2	ZESKANTTAPBOUW M16x20 DIN933
8	3	2REKMON0201	AISI 304	TC KLEMBAND LICHT 50,5
7	3	DT0000-NA		VOEDINGSNOZZLE Ø20 (3/4")
6	3	2REKMON0203	SILICONE	TC AFDICHTING DIN DN40/50,5
5	1	DFZ0000-ZC	PP GRIJS	BLOKKEERSEGMENT RECHTS
4	1	DFZ0000-ZB	PP GRIJS	BLOKKEERSEGMENT LINKS
3	2	2CCDFZ00075	SILICONE	AANDRUKRUBBER 10x6
2	2	DT0000-ZA	PP GRIJS	AANDRUKSEGMENT
1	1	DT0600-2A	AISI 304	CASCO 600DT
ITEM	QTY	PART NUMBER	MATERIAL	DESCRIPTION

TITLE: ZEEFBOCHT7/SCREEN 600DT		SCALE: 1:10	A1			
MATERIAL:		MASS: 211,50 kg				
 REKO Industrial Equipment BV The Netherlands www.reko.com		REV	REV STATUS	DATE	BY	DRAWING NUMBER DT0600-2
		1	Released	29-12-20	SK	
		2	Released	28-01-21	SK	
		3	Released	22-04-21	SK	
4	Released	21-07-21	SK			

GEN. DIM. TOLERANCES ACC. TO ISO 2768-mk
WELDING TOLERANCES ACC. TO ISO 13920-AE
SHARP EDGES REMOVED ACC. TO ISO 13715

© THIS DRAWING IS ISSUED BY REKO INDUSTRIAL EQUIPMENT BV SUBJECT TO THE CONDITIONS THAT IT IS NOT COPIED EITHER IN WHOLE OR IN PART OR DISCLOSED TO THIRD PARTIES UNLESS PRIOR WRITTEN AUTHORISATION IS GIVEN BY REKO INDUSTRIAL EQUIPMENT BV

DN150 PN10
EN1092-1 T02

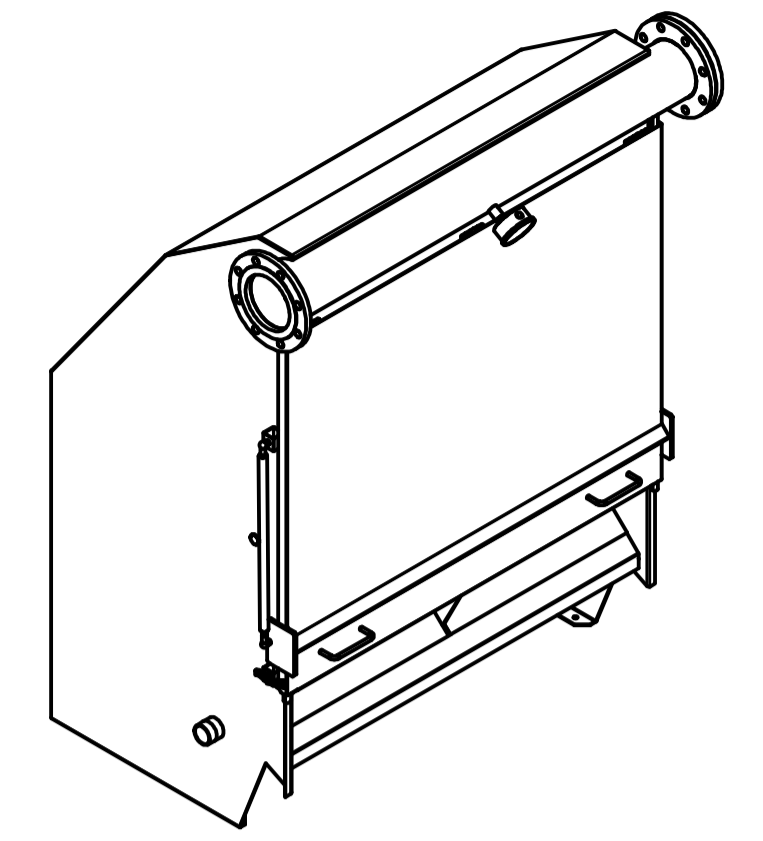
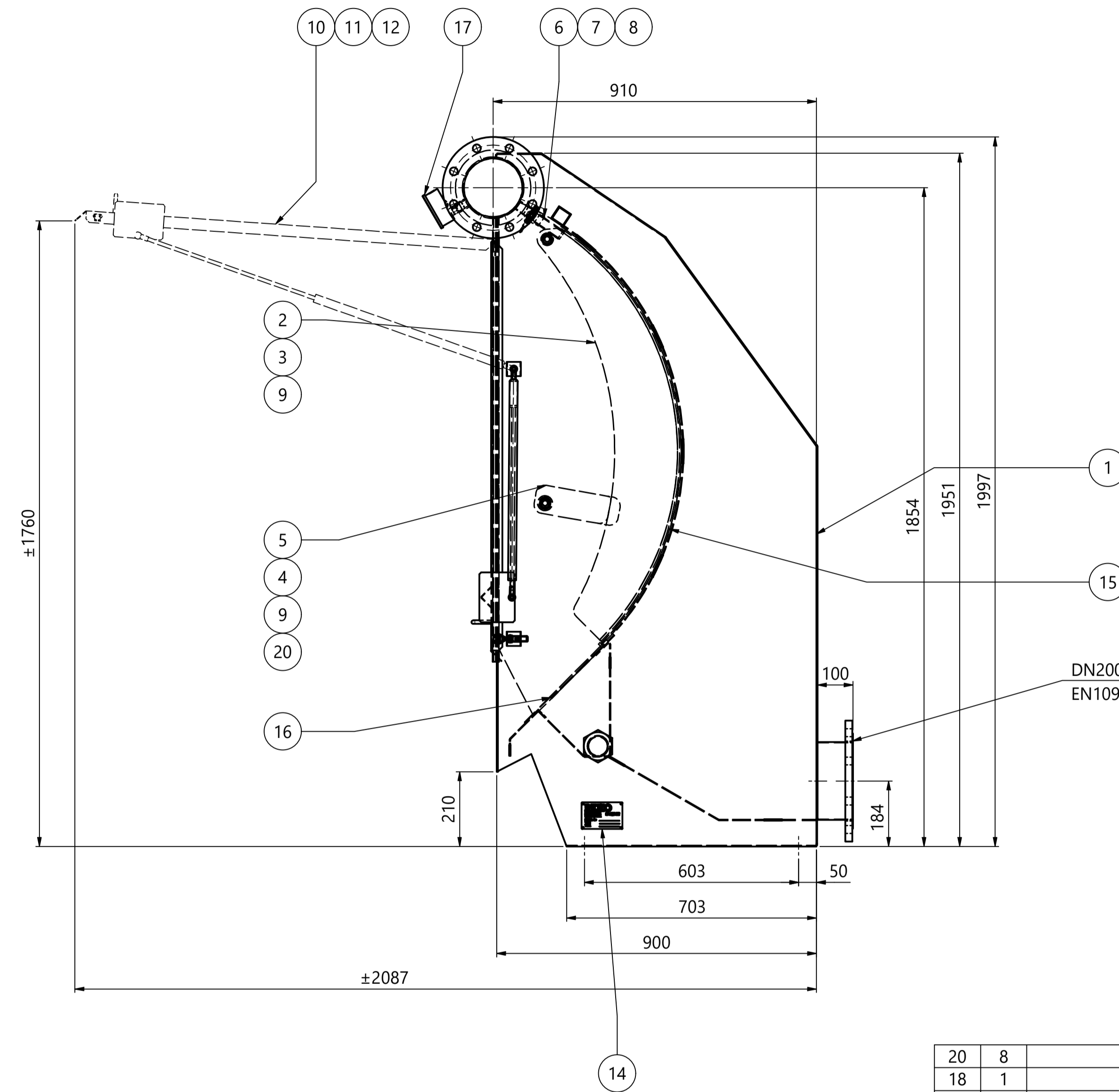
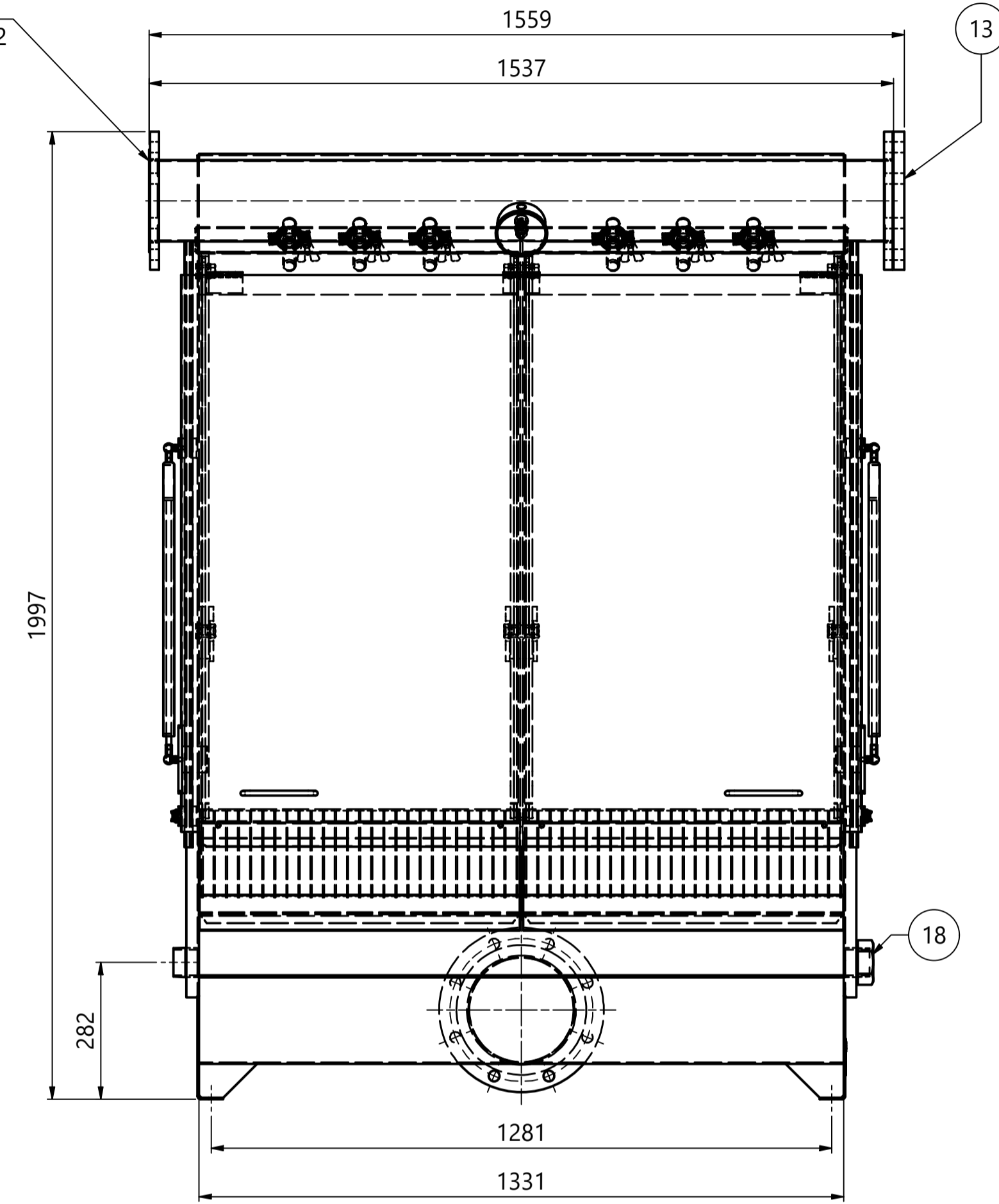

FLENZEN : GECOAT ALUMINIUM
FLANGES : COATED ALUMINIUM

DN200 PN10
EN1092-1 T02

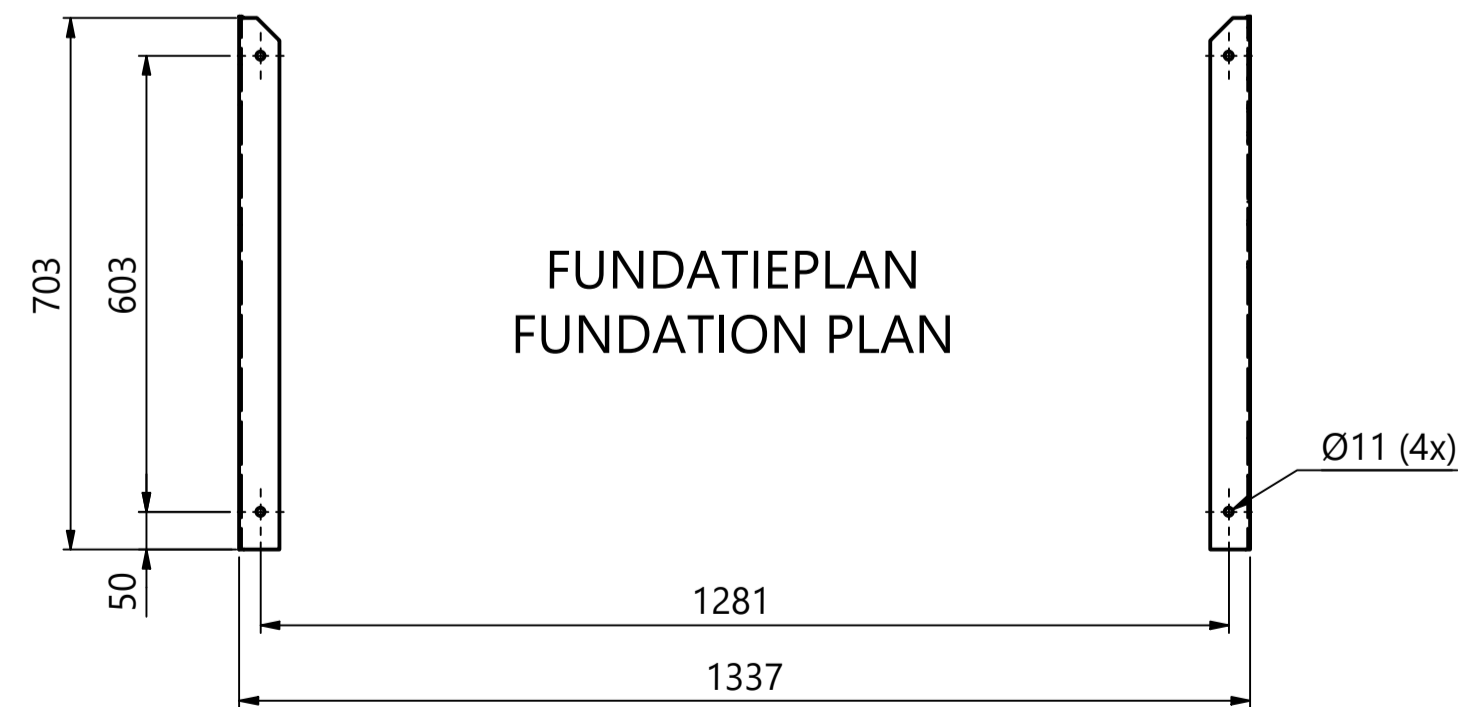

20	8		A2	VLAKKE SLUITRING M16 DIN125
18	1		PVC	CAP 2"
17	1		AISI 304	MANOMETER 1/2" (A) 100mm 0-6bar
16	2	DT0600-O	AISI 304	ONTWATERINGSPLAAT
15	2	DT0600-ZE	AISI 316 (WW)	ZEEFPLAAT 300DT
14	1	2REKKIG49-2	AISI 316	TYPE PLAAT
13	1		AISI 304	BLINDFLENS DN150 PN10 EN1092-1 T05
12	2	ROD500SC0550		GASDRUKVEER 10/22 500MM 550N
11	2	2REKE101119	EPDM	AFDICHTING 1011-19 L=1500
10	1	DT1200-C		VOORDEKSEL 1200DT
9	8		A2	ZESKANTTAPBOUW M16x20 DIN933
8	6	2REKMON0201	AISI 304	TC KLEMBAND LICHT 50,5
7	6	DT0000-NA		VOEDINGSNOZZLE Ø20 (3/4")
6	6	2REKMON0203	SILICONE	TC AFDICHTING DIN DN40/50,5
5	2	DFZ0000-ZC	PP GRIJS	BLOKKEERSEGMENT RECHTS
4	2	DFZ0000-ZB	PP GRIJS	BLOKKEERSEGMENT LINKS
3	2	2CCDFZ00075	SILICONE	AANDRUKRUBBER 10x6
2	4	DT0000-ZA	PP GRIJS	AANDRUKSEGMENT
1	1	DT1200-2A	AISI 304	CASCO 1200DT
ITEM	QTY	PART NUMBER	MATERIAL	DESCRIPTION

TITLE: ZEEFBOCHT7/SCREEN 1200DT				SCALE: 1:10	A1
MATERIAL:				MASS: 342,18 kg	
0	Released	29-12-20	SK		
1	Released	11-08-21	SK		
DRAWING NUMBER				DT1200-2	
<small>GEN. DIM. TOLERANCES ACC. TO ISO 2768-mk WELDING TOLERANCES ACC. TO ISO 13920-AE SHARP EDGES REMOVED ACC. TO ISO 13715</small>					
<small>© THIS DRAWING IS ISSUED BY REKO INDUSTRIAL EQUIPMENT BY SUBJECT TO THE CONDITIONS THAT IT IS NOT COPIED EITHER IN WHOLE OR IN PART OR DISCLOSED TO THIRD PARTIES UNLESS PRIOR WRITTEN AUTHORISATION IS GIVEN BY REKO INDUSTRIAL EQUIPMENT BY</small>					

12 11 10 9 8 7 6 5 4 3 2 1

H
G
F
E
D
C
B
A

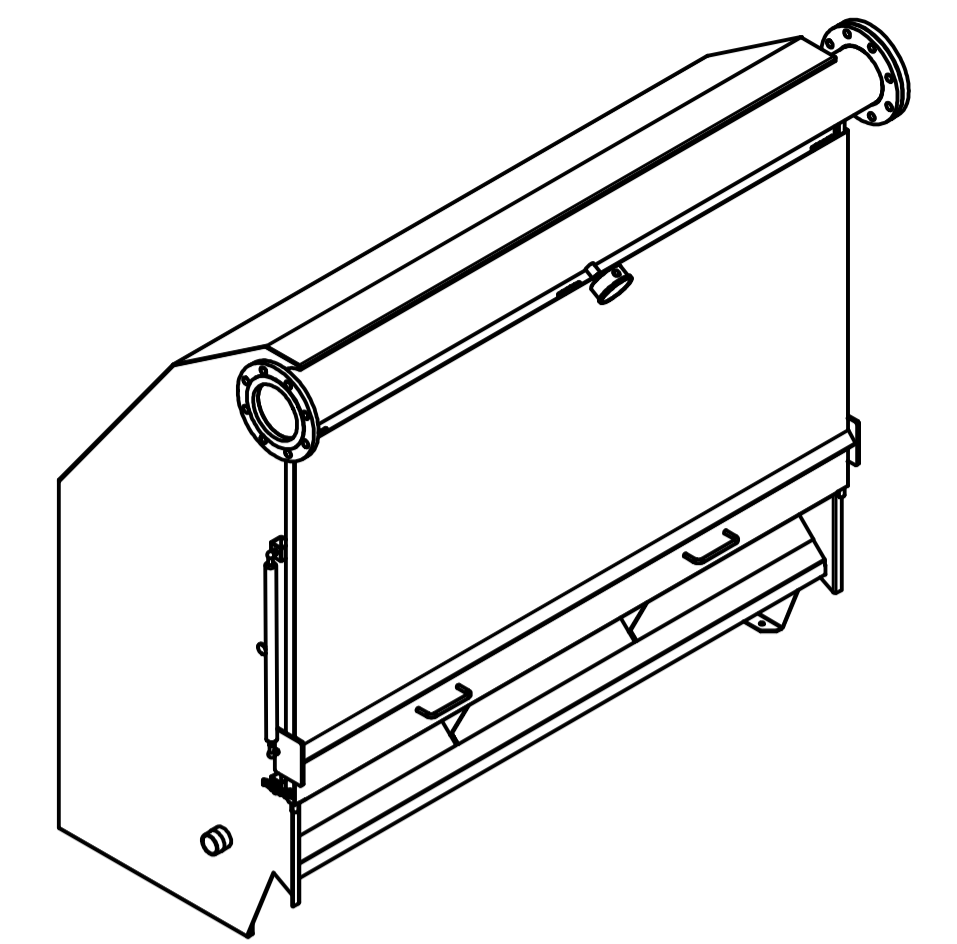
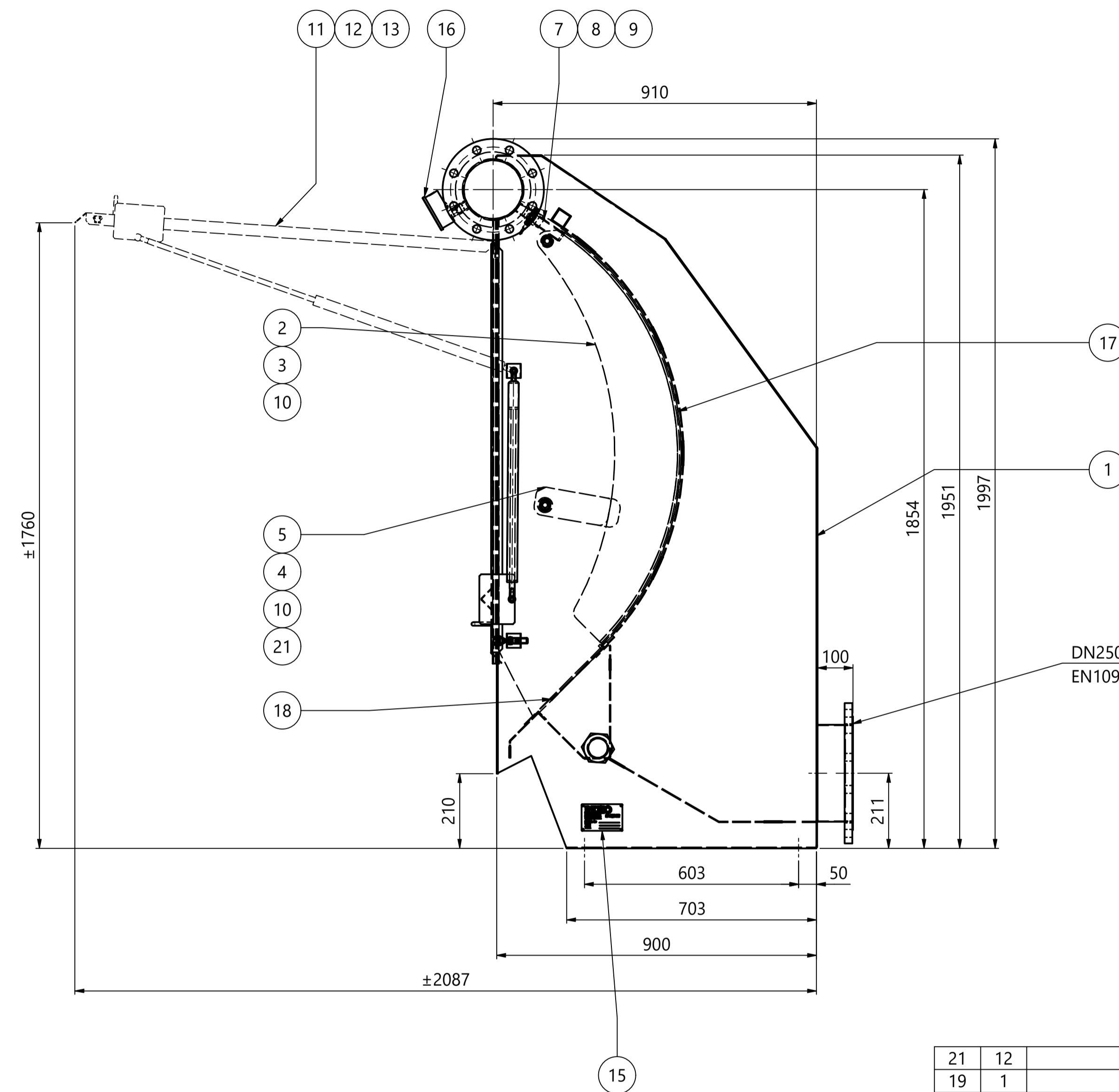
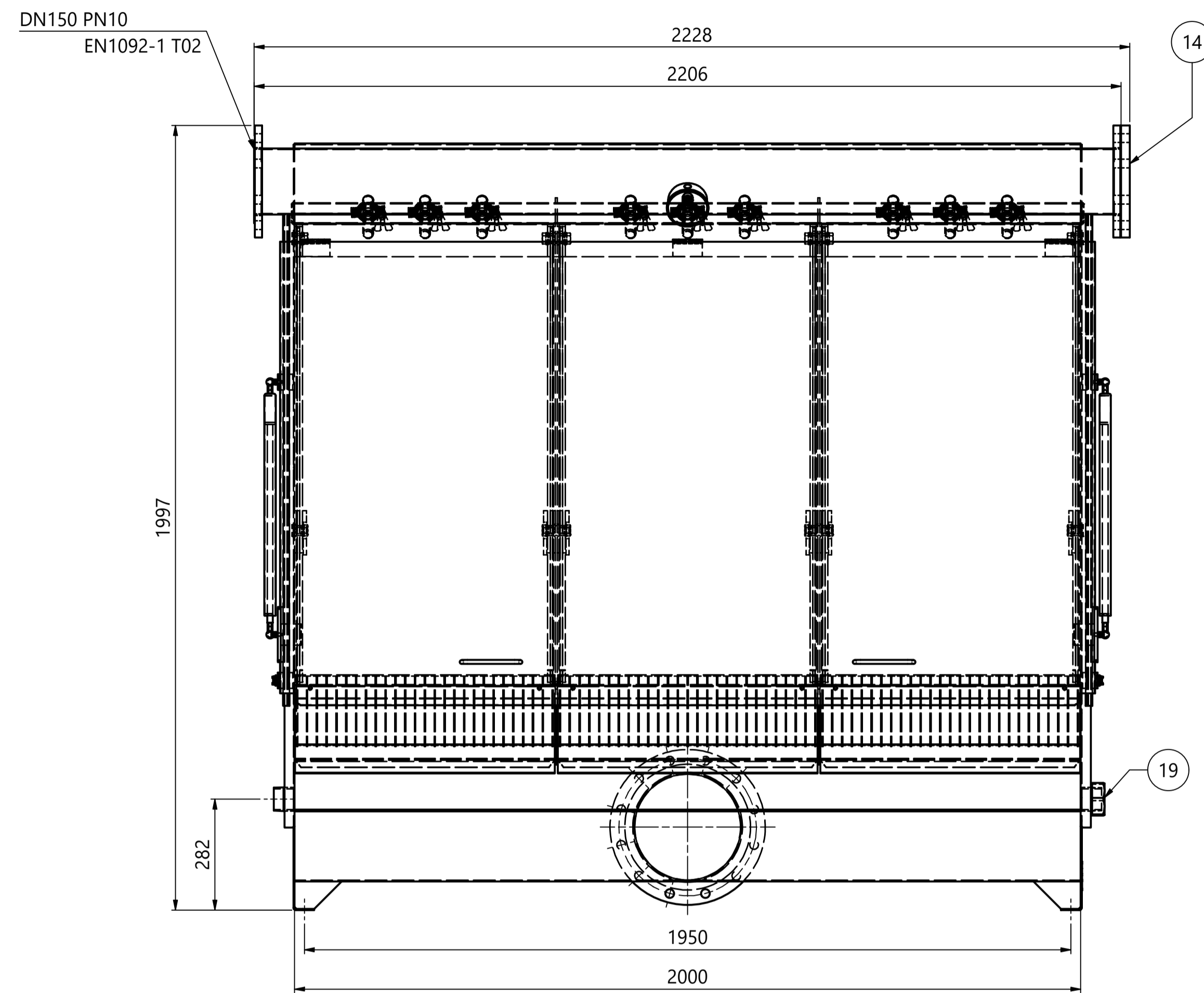

FLENZEN : GECOAT ALUMINIUM
FLANGES : COATED ALUMINIUM

DN250 PN10
EN1092-1 T02

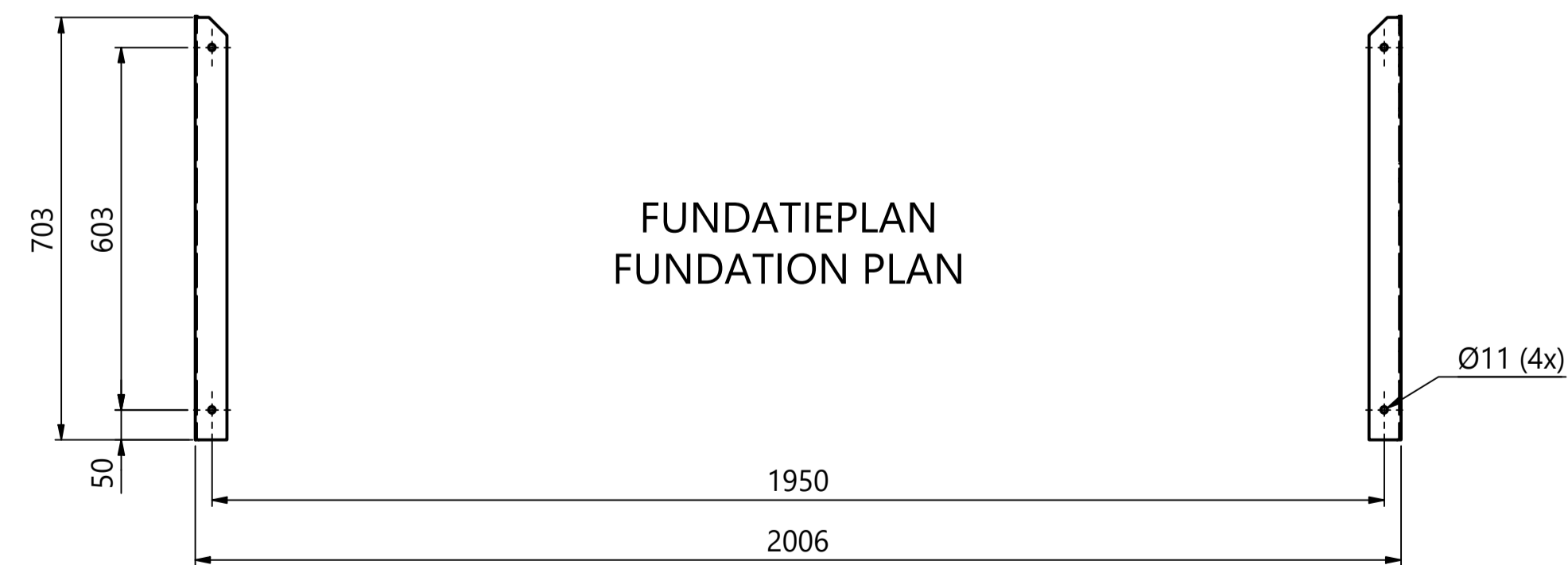

21	12		A2	VLAKKE SLUITRING M16 DIN125
19	1		PVC	CAP 2"
18	3	DT0600-O	AISI 304	ONTWATERINGSPLAAT
17	3	DT0600-ZE	AISI 316 (WW)	ZEEFPLAAT 300DT
16	1		AISI 304	MANOMETER 1/2" (A) 100mm 0-6bar
15	1	2REKKIG49-2	AISI 316	TYPE PLAAT
14	1		AISI 304	BLINDFLENS DN150 PN10 EN1092-1 T05
13	2	ROD500SD0850		GASDRUKVEER 14/28 500MM 850N
12	2	2REKE101119	EPDM	AFDICHTING 1011-19 L=1500
11	1	DT1800-C		VOORDEKSEL 1800DT
10	12		A2	ZESKANTTAPBOUT M16x20 DIN933
9	9	2REKMON0201	AISI 304	TC KLEMBAND LICHT 50,5
8	9	DT0000-NA		VOEDINGSNOZZLE Ø20 (3/4")
7	9	2REKMON0203	SILICONE	TC AFDICHTING DIN DN40/50,5
5	3	DFZ0000-ZC	PP GRIJS	BLOKKEERSEGMENT RECHTS
4	3	DFZ0000-ZB	PP GRIJS	BLOKKEERSEGMENT LINKS
3	2	2CCDFZ00075	SILICONE	AANDRUKRUBBER 10x6
2	6	DT0000-ZA	PP GRIJS	AANDRUKSEGMENT
1	1	DT1800-2A	AISI 304	CASCO 1800DT
ITEM	QTY	PART NUMBER	MATERIAL	DESCRIPTION

TITLE: ZEEFBOCHTT/SCREEN 1800DT		SCALE: 1:10	A1		
MATERIAL:		MASS: 473,71 kg			
REKO REKO Industrial Equipment BV The Netherlands www.reko.com	REV 0	Released	29-12-20	SK	CHECKED
	REV 1	Released	11-08-21	SK	DRAWING NUMBER
					DT1800-2

GEN. DIM. TOLERANCES ACC. TO ISO 2768-mk
WELDING TOLERANCES ACC. TO ISO 13920-AE
SHARP EDGES REMOVED ACC. TO ISO 13715

© THIS DRAWING IS ISSUED BY REKO INDUSTRIAL EQUIPMENT BY SUBJECT TO THE CONDITIONS THAT IT IS NOT COPIED EITHER IN WHOLE OR IN PART OR DISCLOSED TO THIRD PARTIES UNLESS PRIOR WRITTEN AUTHORISATION IS GIVEN BY REKO INDUSTRIAL EQUIPMENT BV

12 11 10 9 8 7 6 5 4 3 2 1