

econ®



Fig. No.	6731
Size	DN150
Flange	PN63/10/16/20
P. max.	10bar
Body	CF8M
Seat	EPDM 23110°C
Disc	CF8M
S.No.	100172533
Y.O.M.	10/10
econ CE www.econ.com 0038	

Butterfly Valves Series 67 & 68

Building services
HVAC

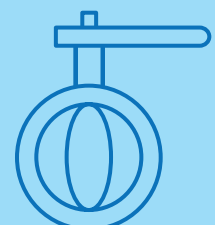

Proven quality since 1892

More than 125 years of application experience, research and product development forms the basis of the today's Econ® product designs. The resilient seated butterfly valve series 67 and 68 are the example of well-engineered products at a very competitive price.

Applications

The series 67 and 68 butterfly valves have been developed for building services, greenhouses and food & beverage applications, but have proven to perform well in the below mentioned markets:

Markets

- HVAC / Building services
- Greenhouses
- Food & Beverage
- Marine / Shipbuilding
- Mining
- Steel production
- Desalination, water and waste water treatment
- Pulp & Paper

DVGW

The series 67 and 68 butterfly valves have been tested according to the EN 13774 standard and have been approved by DVGW for gas distribution applications up to a pressure of 16 bar.

Food contact materials

EC1935 and FDA approved

The butterfly valve versions with TFM (modified PTFE) lined rubber seats are designed for food applications. The disc and the seat, parts which are in contact with foodstuff, have been migration tested by an external laboratory and do fully comply with the EC1935 and FDA regulations.



Lug type
DVGW-certified
Fig. 68321

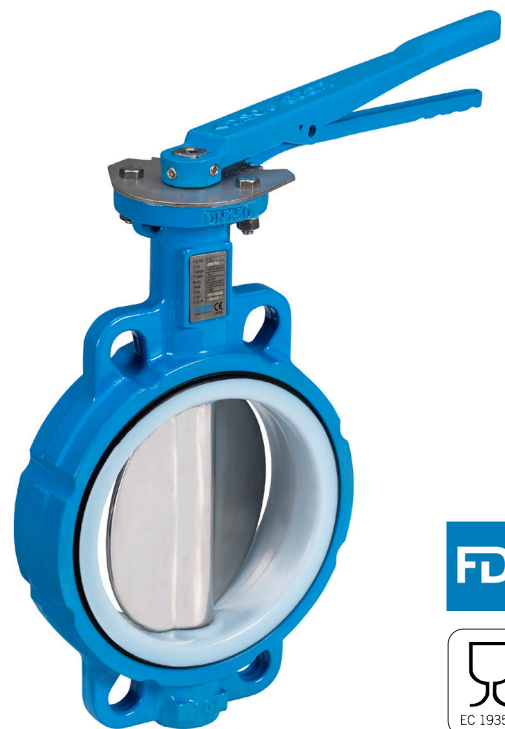

Wafer type with TFM 1600 seat and
stainless steel polished disc for food
applications Fig. 6731





Design

The series 67 and 68 valves have a robust one-piece stem design with a free of play spline disc-stem connection. The valves have a replaceable seat which covers the full body as a liner and isolates flowing media from the valve body and stem.



Fig. 6731 - Wafer type with centring lugs and hand lever

The replaceable rubber valve seat is vulcanized on a phenolic or aluminium back-up ring. This construction makes this valve very well suitable for both high velocity flow and vacuum applications. The series 68 lug type is not suitable for dead-end services. For this application we recommend using the Econ® butterfly valve series 64 or 58.



Fig. 6822 - Lug type with gear box

- Valve design according to EN 593, API 609 and ASME B16.34
- Anti-blow out stem design
- Top-flange according to ISO 5211
- Phenolic or aluminium backed seat
- Face to face dimension according to EN 558 Series 20, ISO 5752 series 20 and API 609 Category A
- Size range DN25 - DN600 (1" - 24")
- Size range TFM 1600 seated valves DN40 - DN300 (1.½" - 12")
- Splined stem-disc connection DN25 - DN300 (1" - 12"). Larger valve dimensions have a pinned stem-disc connection
- To be mounted between flanges according to EN 1092-1 and 2 (flange type 11) and/or ASME B16.5. Remark: Series 68 in DN65 with 4 bolt holes, 8 holes on request
- Bidirectional bubble tight shutoff according to EN 12266-1 leakage rate A and API 598
- Pressure classes and flange connections
 - Wafer type:
 - Size DN25 - DN300 (1" - 12"): PN6, PN10, PN16 and class 150
 - Size DN350 - DN400 (14" - 16"): PN10, PN16 and class 150
 - Size DN450 - DN600 (18" - 24"): PN10 or PN16 or class 150
 - Lug type
 - Size DN25 - DN150 (1" - 6"): PN10 and PN16 or class 150
 - Size DN200 - DN600 (8" - 24"): PN10 or PN16 or class 150
- Delta P max.: 10 bar (145 psi) or 16 bar (232 psi)

Disc and seat selection

Due to the rubber seated butterfly valve design, only the disc and the seat are in contact with the medium and therefore these parts must be made of materials which have a good chemical resistance to the medium.

The upper temperature limitation of the valve is limited by the seat material. The lower temperature limitation is either limited by the valve body or seat material. In this case the valve body is always made of ductile iron. See the below table for more information and the available seat materials.

Available seat materials	Temperature limitations	
EPDM	-10° ~ +110°C	(14° ~ 230°F)
NBR / BUNA-N	-10° ~ +80°C	(14° ~ 176°F)
FPM / FKM	-10° ~ +180°C	(14° ~ 356°F)
TFM 1600 lined EPDM (food grade)	-10° ~ +110°C	(14° ~ 230°F)

According to EN 593 (Industrial valves - Metallic butterfly valves for general purposes) ductile iron butterfly valves may be used down to a minimal temperature of -10°C!

Coating

Series 67 and 68 butterfly valves have a one layer UV-resistant Polyester powder coating for high durability and good chemical resistance.

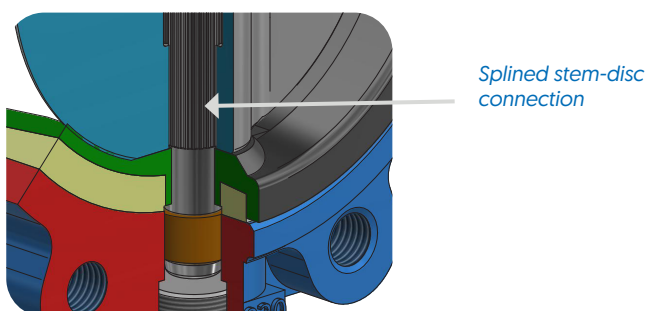

Parts and materials

Pos.	Part	Material
1	Body	A536-65-45-12 [EN-GJS-400-15] + Polyester powder coating
2	Stem	AISI 410 [1.4006] up to DN150 [6"] and AISI 431 [1.4057] for larger sizes
3	Disc	A351-CF8M [1.4408] or CC333G [B148-C95800]
4	Seat	EPDM, NBR, FKM [FPM] or TFM 1600 lined EPDM [food grade]
5	Seat back-up ring	DN25 - DN350 [1" - 14"]: Phenolic * DN400 - DN600 [16" - 24"]: Aluminium

Pos.	Part	Material
6	Anti-blow-out washer and circlips	AISI 304 [1.4301]
7	Top stem bearings	PTFE coated ASTM-A36 bushings
8	Bottom stem bearing	Brass bearing bushing
9	Stem plug	Galvanized carbon steel
10	Bottom gasket	PTFE

* Butterfly valves with a TFM 1600 (modified PTFE) lined seat have a Polyester back-up ring and a AISI 431 [1.4057] stem.

Features

ISO-top flange and square stem connection for direct actuator mounting. No mounting set needed.

Blow out proof stem

Three point stem bearing for high cycle durability

Wafer type body or lug type body

Replaceable phenolic or aluminium backed seat. Seats available in several compounds, also for food applications in compliance with FDA and EC 1935 regulations

Free of play spline stem-disc connection.
Easy disassembly of the valve.

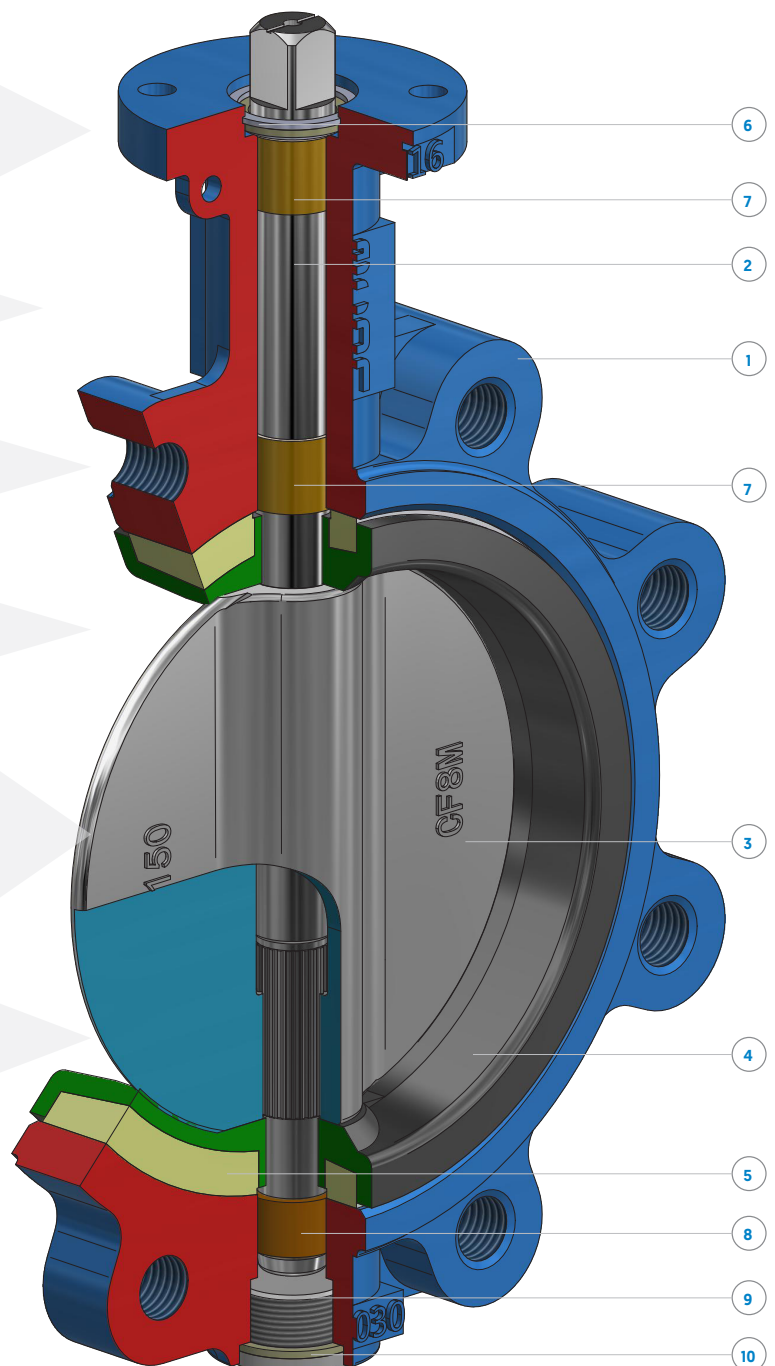



Hand Operated valves

Econ® butterfly valves can be hand operated by means of a hand lever up to size DN200/8" or a worm gearbox for all sizes.

Hand levers have a notching plate in order to put them in intermediate positions. These positions are also lockable by use of a padlock.

Hand levers with intermediate locking positions:

1. Fig. 4001J - Robust malleable iron hand lever with a stainless steel AISI 304 notching plate DN25 - DN200 (1" - 8")
2. Fig. 4001K - Lightweight aluminium hand lever DN25 - DN150 (1" - 6")

Both hand levers can be locked with a padlock.

Worm gearboxes are available for all valve sizes and are useful in situations in which the valve operating space is limited.

Three worm gearboxes are available:



Fig. 4002 | Lightweight aluminium gearbox for indoor use



Fig. 4023 | Heavy duty cast iron gearbox for indoor use



Fig. 4025 | Heavy duty cast iron gearbox for outdoor use, including UL-vane

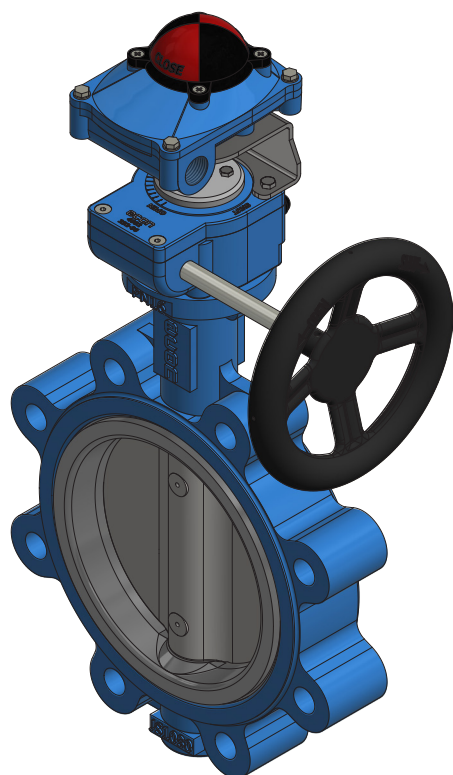

Fig. 6832 DN150 with gear box Fig. 4002 and switch box Fig. 79651

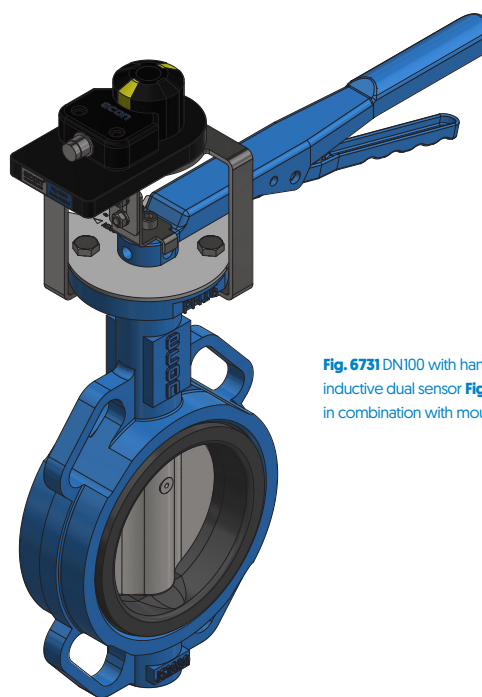

Fig. 6731 DN100 with hand lever Fig. 4001J and inductive dual sensor Fig. 79655 in combination with mounting plate Fig. 7964



Fig. 4001J



Fig. 4001K

Lever and gear box operated valves can also be equipped with a switch box or inductive dual sensors for position feedback.

Automated valves

Econ® butterfly valves have a direct-mount ISO-top flange and square stem connection. All Econ® actuators can be mounted on the valve, without the use of a bracket and coupler.

For remote controlled valves Econ® has 4 automation options available:

1. Pneumatic operated

- a. Rack & Pinion double acting or spring return actuator
Fig. 7902 and 7901 (Metric) or Fig. 7951 and 7952 (Imperial)
- b. Scotch Yoke double acting or spring return actuator
Fig. 7991 and 7992.

Features:

- High cycle life
- Quick opening and closing times
- Torque output up to 6,421 Nm [56,831 in-lb]
- Relatively inexpensive type of automation if a large amount of remote operated valves are needed

2. Electric operated - 115, 230, 380 or 440 VAC 50/60Hz, 24VDC or 24VAC

- a. Open-close actuator - *Fig. 7907*
- b. Fail-safe actuator with rechargeable battery pack – *Fig.7907RBP*
- c. Fail-safe spring return actuator – *Fig. 7917*
- d. Modulating actuator – *Fig. 7907MOD*
- e. Explosion proof [Exd] versions

Features:

- Relative short cycle life compared to pneumatic actuators
- Relatively long operation/cycle times
- Torque output up to 3.000 Nm [26,552 in-lb]
- Relatively inexpensive type of operation if only a few remote operated valves are needed and if no air supply is present
- SIL 2 capable. SIL 3 capable in a redundant setup
- Optional fieldbus communication protocols: Modbus, CANopen, Profibus and AS-interface





3. Hydraulic operated

- a. Compact double acting or spring return Helical actuator
Fig. 21204, 21202 and 21201
- b. Rack & Pinion double acting or spring return actuator
Fig. 21501 and 21502
- c. Scotch Yoke double acting or spring return actuator
Fig. 7991 and 7992

Features:

- Extremely robust construction
- Very compact compared to pneumatic actuators, especially the helical actuator
- Torque output up to 250,000 Nm (2.2 million in-lb)
- Submersible

4. Electro-hydraulic operated

- a. Compact double acting or spring return Helical actuator
- b. Rack & Pinion double acting or spring return actuator
- c. Scotch Yoke double acting or spring return actuator

Features:

- An Econ® local power unit (LPU) can be mounted on all Econ hydraulic actuators and is available in a single acting version (Fig. 21301) and a double acting version (Fig. 21302).
- CANopen fieldbus communication is optional

CANopen®



Valve automation accessories for Rack & Pinion and Scotch Yoke actuators

Switch boxes

Econ® Fig. 79650, 79651, 79652 and 79653

- Position feedback device for open, closed or intermediate positions. Also available with a potentiometer and position transmitter for a 4-20mA or 0-10V feedback signal
- The switch boxes can be equipped with mechanical switches or Pepperl and Fuchs proximity sensors
- Econ® switch boxes can also be mounted on actuators for 3-way L- or T-port valves
- Aluminium or stainless steel IP67 or IP68 enclosure
- Fig. 79653 for explosion proof applications (ATEX-classified for zone 1 and 21)
- SIL 2 capable. SIL 3 capable in a redundant setup



Inductive dual sensors

Econ® Fig. 79654, 79655, 79656, 79657, 79658 and 79659

- Compact construction with sturdy plastic IP67 enclosure
- Cable connection types: Plug-in terminal strip, M12 male connector or 2 meter PVC cable
- 2-wire DC sensor with minimum off-state (leakage) current; max. 0,2 mA. Compatible with all modern PLC's and DCS-systems (only for fig. 79654, 79657 and 79658)
- Fig. 79658 for explosion proof applications (ATEX-classified for zone 2 and 22)



Solenoid valves

Fig. 33580

- Namur pilot solenoid valves for direct mounting
- Voltages: 24 AC, 115 AC, 230 AC and 24 DC
- For double acting and single acting actuators (3/2 and 5/2 function)
- Aluminium IP65 enclosure
- DIN 43650 connector



Smart positioners

Fig. 3303 and 3304

- For modulating applications
- Automatic calibration
- Input signal 4-20mA
- Additional modules available for 4-20mA feedback signal or HART protocol communication
- Pressure gauges can be mounted on this positioner as an option.
- ATEX versions available for explosion proof applications (ATEX-classified for zone 1 and 21)





Control panels and cabinets

- Customized solutions based on the functional needs
- Different designs depending on weather effects and environmental influences

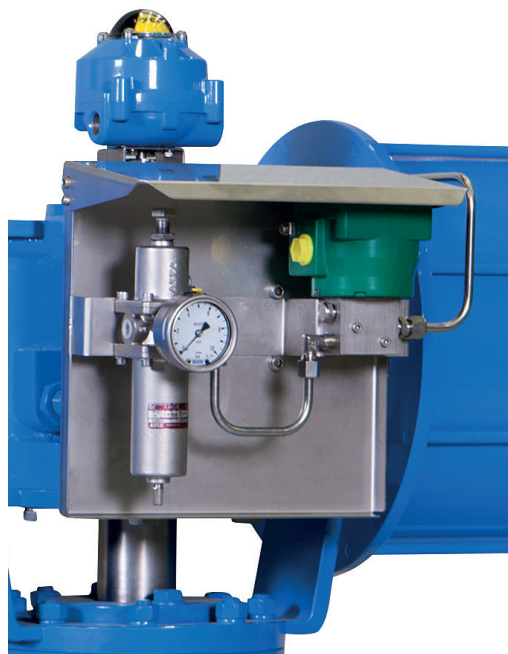

Scotch Yoke actuators

Fig. 7991 and 7992

- Torques up to 250.000Nm
- Double acting and spring return versions
- Pneumatic and hydraulic operated
- ATEX-classified for zone 1,2, 21 and 22
- Safety Integrity Rating IEC 61508 SIL 2 (SIL 3 in redundant configuration)



Actuator protector (DOME)

- Protects the actuator against highly corrosive environments
- Special version available for submerged applications up to 20 meters (65 feet).

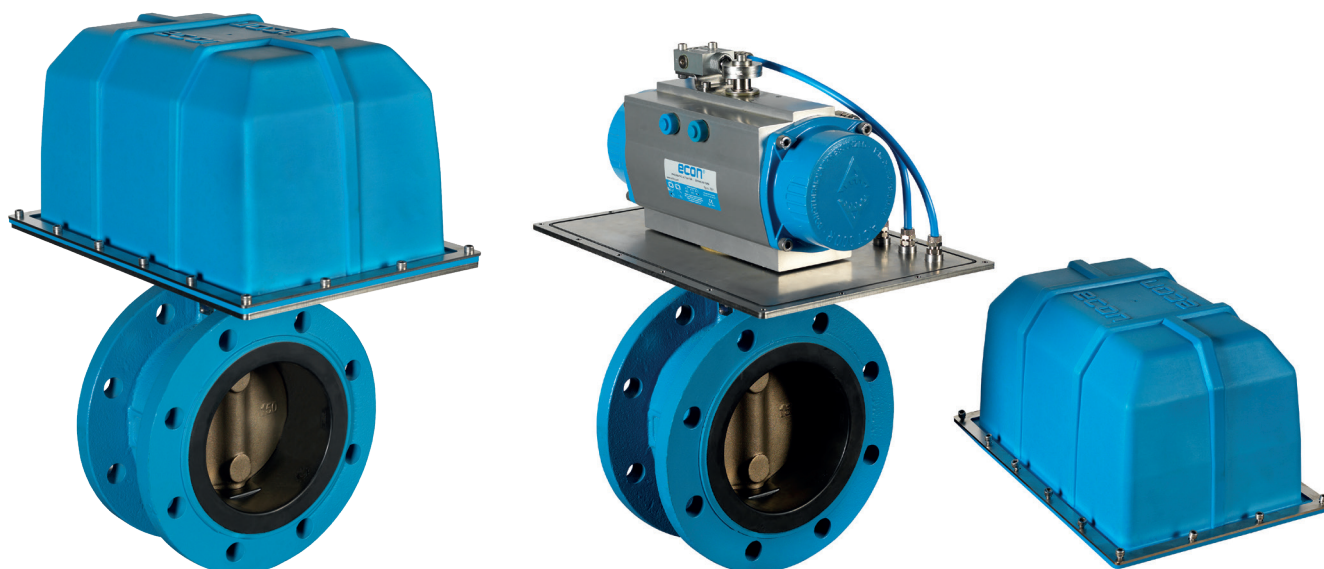

Valve operating torques

Opening (BTO) and closing (BTC) torques in Nm and in-lb															
Valve size		ΔP										MAST			
		EPDM or NBR (Buna-N) seat				FPM/FKM seat				TFM 1600 lined EPDM		Valves with rubber seats		Valves with TFM lined seats	
DN	NPS	10 bar	145 psi	16 bar	232 psi	10 bar	145 psi	16 bar	232 psi	10 bar	145 psi	Nm	in-lb	Nm	in-lb
mm	inch	Nm	in-lb	Nm	in-lb	Nm	in-lb	Nm	in-lb	Nm	in-lb				
25	1"	8	71	9	80	8	71	9	80	-	-	69	611	-	-
32	1.1/4"	8	71	9	80	8	71	9	80	-	-	69	611	-	-
40	1.1/2"	9	80	10	89	8	71	9	80	35	310	69	611	71	625
50	2"	9	80	10	89	8	71	11	98	35	310	69	611	71	625
65	2.1/2"	11	98	13	115	11	98	15	133	45	399	69	611	86	759
80	3"	16	142	19	169	16	142	23	204	65	576	69	611	106	937
100	4"	24	213	28	248	26	234	38	337	85	753	143	1,266	212	1,872
125	5"	40	354	47	416	36	319	60	531	110	974	143	1,266	302	2,674
150	6"	57	505	67	593	64	567	101	894	174	1,540	256	2,266	360	3,186
200	8"	131	1,160	180	1,593	131	1,160	158	1,399	330	2,921	691	6,116	541	4,787
250	10"	224	1,983	310	2,744	248	2,195	338	2,992	549	4,859	1,497	13,249	996	8,811
300	12"	321	2,841	440	3,895	345	3,054	488	4,319	799	7,072	1,497	13,249	1,172	10,373
350	14"	616	5,452	850	7,524	480	4,248	600	5,310	-	-	2,767	24,488	-	-
400	16"	875	7,744	1,200	10,621	750	6,638	1,163	10,293	-	-	2,767	24,488	-	-
450	18"	1,197	10,594	1,600	14,162	1,050	9,293	1,500	13,275	-	-	6,560	58,056	-	-
500	20"	1,590	14,072	2,100	18,587	1,283	11,355	1,875	16,594	-	-	13,685	121,113	-	-
600	24"	2,611	23,108	3,500	30,978	2,209	19,550	-	-	-	-	13,685	121,113	-	-

Notes:

- Torque values for valves with an EPDM or NBR seat in water of 0°C (32°F) up to 80°C (176°F) without solid particles.
- For valves with a FPM/FKM seat an additional factor of 1,2 must be applied on top of the EPDM/NBR torque values.
- Solid particles and fouling of the disc and seat will lead to high torques and accelerated wear.
- High flow velocities (> 4 m/s or 13,1 ft/s) will generate a dynamic torque due to pressure differences across a partly opened valve disc. Please contact your distributor in order to have this dynamic torque calculated.

Application and safety factors for actuator sizing:

- Standard sizing for lubricating media, like water - 1,3
- Sizing for lubricating media and less than once per week operated - 1,5
- Sizing for lubricating media and less than once per month operated - 1,8
- Sizing for (dry) gases and abrasive media - 1,8
- Sizing for media with temperatures below 0°C (32°F) - 1,8



Flow data

Flow data of isolating valves is usually needed for pipe dimension calculations and pressure losses when the valve is in the fully open position. Most of the open/closed isolating valves are in the fully open position the most of the time and therefore these valves should have a high Kv-value in order to reduce pressure drops and with this increasing plant efficiency and reducing energy costs.

Flow coefficient at different disc opening angles

Disc angle (opening angle of the valve)																			
Valve size																			
DN	NPS	10°		20°		30°		40°		50°		60°		70°		80°		90°	
mm	inch	Kv	Cv	Kv	Cv	Kv	Cv	Kv	Cv	Kv	Cv	Kv	Cv	Kv	Cv	Kv	Cv	Kv	Cv
DN25	1"	-	-	-	-	1,9	2.2	6,0	7.0	14,0	16.3	20,0	23.3	29	34	40	47	45	53
DN32	1.1/4"	-	-	-	-	1,9	2.2	6,0	7.0	14,0	16.3	20,0	23.3	29	34	40	47	45	53
DN40	1.1/2"	-	-	-	-	4,7	5.5	9,5	11.1	20,0	23.3	30	35	41	48	53	62	59	69
DN50	2"	0,09	0.1	4,3	5.0	10,4	12.0	21,0	24.0	39	45	55	64	78	90	108	125	117	135
DN65	2.1/2"	0,18	0.2	6,9	8.0	17,3	20.0	32	37	56	65	85	98	125	144	176	204	190	220
DN80	3"	0,26	0.3	10,4	12.0	19,0	22.0	34	39	61	70	100	116	158	183	238	275	261	302
DN100	4"	0,44	0.5	14,7	17.0	31	36	67	78	120	139	199	230	315	364	472	546	519	600
DN125	5"	0,70	0.8	25	29	53	61	115	133	205	237	339	392	536	620	804	930	884	1,022
DN150	6"	1,7	2.0	39	45	82	95	177	205	317	366	523	605	829	958	1,243	1,437	1,366	1,579
DN200	8"	2,6	3.0	77	89	163	188	353	408	629	727	1,040	1,202	1,646	1,903	2,469	2,854	2,713	3,136
DN250	10"	3,5	4.0	131	151	277	320	600	694	1,070	1,237	1,771	2,047	2,803	3,240	4,203	4,859	4,619	5,340
DN300	12"	4,3	5.0	202	234	428	495	927	1,072	1,653	1,911	2,735	3,162	4,329	5,005	6,494	7,507	7,136	8,250
DN350	14"	5,2	6.0	292	338	618	715	1,340	1,549	2,388	2,761	3,951	4,568	6,254	7,230	9,380	10,844	10,308	11,917
DN400	16"	6,9	8.0	401	464	850	983	1,842	2,130	3,284	3,797	5,434	6,282	8,600	9,942	12,900	14,913	14,176	16,388
DN450	18"	9,5	11.0	532	615	1,126	1,302	2,441	2,822	4,349	5,028	7,197	8,320	11,390	13,168	17,085	19,752	18,775	21,705
DN500	20"	12,1	14.0	684	791	1,448	1,674	3,138	3,628	5,592	6,465	9,254	10,698	14,645	16,931	21,968	25,396	24,140	27,908
DN600	24"	19,0	22.0	1,057	1,222	2,238	2,587	4,848	5,605	8,640	9,989	14,297	16,528	22,626	26,157	33,939	39,236	37,295	43,116

Notes:

- The valve is fully open at an angle of 90°
- Kv is the volume of water in m³ per hour at a ΔP of 1 bar
- Cv is the volume of water in US Gallons per minute at a ΔP of 1 psi

Dimensions series 67 | Wafer type

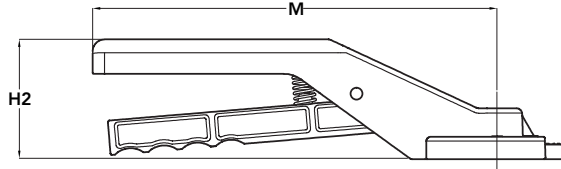

Aluminium lever - Fig. 4001K

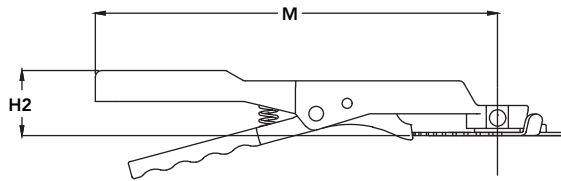

Malleable iron lever - Fig. 4001J

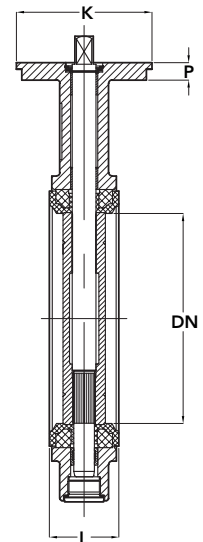
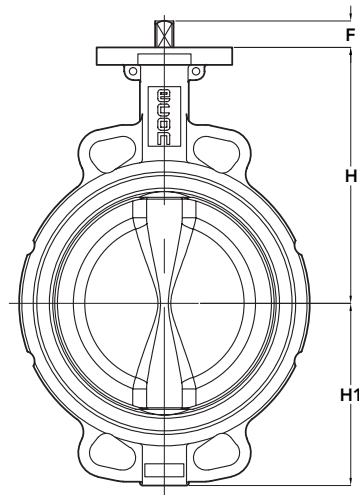
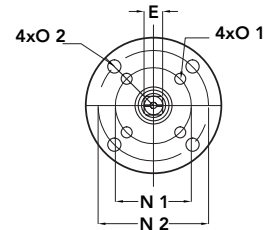

DN25-DN300
1"-12"

DN	NPS	H	H	H1	H1	H2	H2	H2	H2	M	M	M	M	L	L	P	P	K	K	□E	□E	F	F	ØN1	ØN1	ØN2	ØN2
mm	inch	mm	inch	mm	inch	mm	inch	mm	inch	mm	inch	mm	inch	mm	inch	mm	inch	mm	inch	mm	inch	mm	inch	mm	inch	mm	inch
25	1"	115	4.53	57	2.24	30	1.18	68	2.68	195	7.68	200	7.87	32	1.26	12	0.47	65	2.56	11	0.43	13,5	0.53	50	1.97		
32	1¼"	115	4.53	57	2.24	30	1.18	68	2.68	195	7.68	200	7.87	32	1.26	12	0.47	65	2.56	11	0.43	13,5	0.53	50	1.97		
40	1½"	115	4.53	68	2.68	30	1.18	68	2.68	195	7.68	200	7.87	33	1.30	12	0.47	65	2.56	11	0.43	13,5	0.53	50	1.97		
50	2"	143	5.63	72	2.83	30	1.18	68	2.68	265	10.43	200	7.87	43	1.69	12	0.47	65	2.56	11	0.43	13,5	0.53	50	1.97		
65	2½"	156	6.14	78	3.07	30	1.18	68	2.68	265	10.43	200	7.87	46	1.81	13	0.51	65	2.56	11	0.43	13,5	0.53	50	1.97		
80	3"	162	6.38	95	3.74	30	1.18	68	2.68	265	10.43	200	7.87	46	1.81	13	0.51	65	2.56	11	0.43	13,5	0.53	50	1.97		
100	4"	177	6.97	108	4.25	31	1.22	80	3.15	265	10.43	270	10.63	52	2.05	14	0.55	90	3.54	14	0.55	17,5	0.69	50	1.97	70	2.76
125	5"	190	7.48	123	4.84	31	1.22	80	3.15	265	10.43	270	10.63	56	2.20	14	0.55	90	3.54	14	0.55	17,5	0.69	70	2.76		
150	6"	205	8.07	138	5.43	32	1.26	80	3.15	328	12.91	270	10.63	56	2.20	14	0.55	90	3.54	17	0.67	18,5	0.73	70	2.76		
200	8"	236	9.29	168	6.61	37	1.46			386	15.20			60	2.36	16	0.63	125	4.92	17	0.67	24,5	0.96	70	2.76	102	4.02
250	10"	267	10.51	207	8.15									68	2.68	16	0.63	125	4.92	22	0.87	24,5	0.96	102	4.02	140	5.51
300	12"	308	12.13	243	9.57									78	3.07	16	0.63	150	5.91	22	0.87	30,0	1.18	102	4.02	140	5.51
350	14"	368	14.49	272	10.71									78	3.07	20	0.79	210	8.27	27	1.06	30,0	1.18	140	5.51	165	6.50
400	16"	400	15.75	342	13.46									102	4.02	20	0.79	210	8.27	27	1.06	30,0	1.18	140	5.51	165	6.50
450	18"	422	16.61	372	14.65									114	4.49	20	0.79	210	8.27	36	1.42	39,0	1.54	140	5.51	165	6.50
500	20"	480	18.90	402	15.83									127	5.00	22	0.87	210	8.27	46	1.81	49,0	1.93	140	5.51	165	6.50
600	24"	562	22.13	467	18.39									154	6.06	25	0.98	300	11.81	46	1.81	49,0	1.93	165	6.50	254	10.00

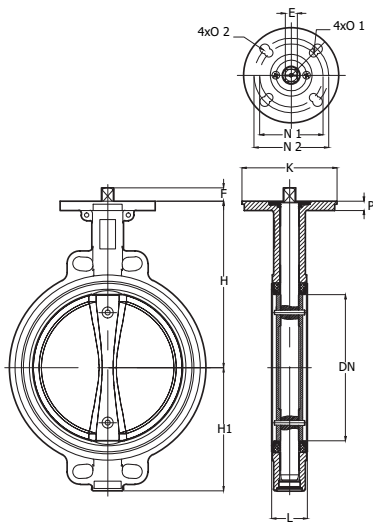

DN350
14"

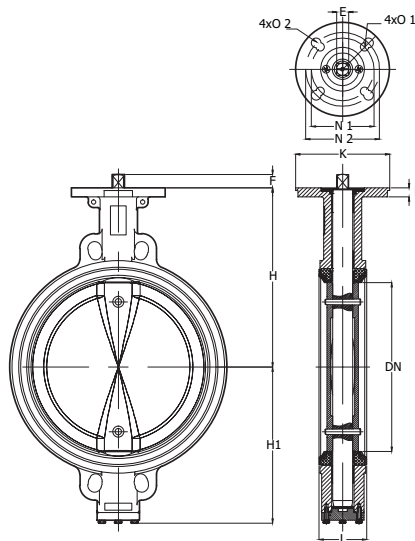

DN400
16"

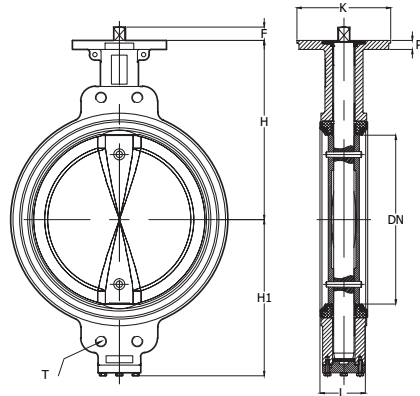
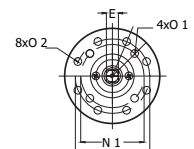
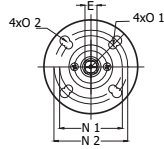

DN450-DN500
18"-20"

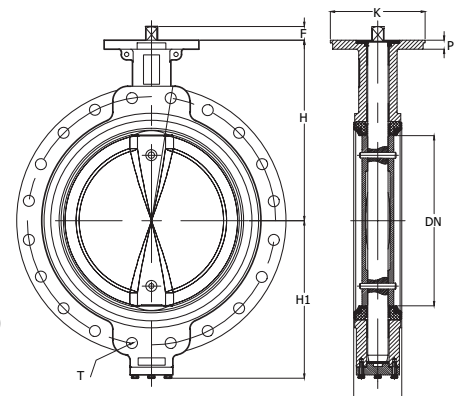

DN600
24"

DN	NPS	ØO1	ØO1	ØO2	ØO2	T	T	T	PCD	PCD	PCD	PCD	PCD	PCD	PCD	without	without	with	with	with	with	
mm	inch	mm	inch	mm	inch	PN10	PN16	CL 150	PN6	PN6	PN10	PN10	PN16	PN16	CL 150	lever	lever	lever	lever	lever	lever	
									mm	inch	mm	inch	mm	inch	mm	kg	lb	kg	lb	kg	lb	
25	1"	7	0.28						75	2.95	85	3.35	85	3.35	79	3.11	1,6	3,5	2,1	4,6	2,1	4,6
32	1¼"	7	0.28						90	3.54	100	3.94	100	3.94	89	3.50	1,7	3,7	2,2	4,9	2,2	4,9
40	1½"	7	0.28						100	3.94	110	4.33	110	4.33	100	3.94	2,0	4,4	2,5	5,5	2,5	5,5
50	2	7	0.28						110	4.33	125	4.92	125	4.92	121	4.76	2,7	6,0	3,5	7,7	3,5	7,7
65	2½"	7	0.28						130	5.12	145	5.71	145	5.71	140	5.51	3,6	7,9	4,4	9,7	4,4	9,7
80	3"	7	0.28						150	5.91	160	6.30	160	6.30	152	5.98	3,9	8,6	4,7	10,4	4,7	10,4
100	4"	7	0.28	10	0.39				170	6.69	180	7.09	180	7.09	190	7.48	5,0	11,0	5,8	12,8	5,8	12,8
125	5"	10	0.39						200	7.87	210	8.27	210	8.27	216	8.50	7,0	15,4	7,8	17,2	7,8	17,2
150	6"	10	0.39						225	8.86	240	9.45	240	9.45	241	9.49	8,0	17,6	9,0	19,8	9,0	19,8
200	8"	10	0.39	12	0.47				280	11.02	295	11.61	295	11.61	298	11.73	13,2	29,1	14,9	32,8		
250	10"	12	0.47	18	0.71				335	13.19	350	13.78	355	13.98	362	14.25	19,0	41,9				
300	12"	12	0.47	18	0.71				395	15.55	400	15.75	410	16.14	432	17.01	31,0	68,3				
350	14"	18	0.71	22	0.87						460	18.11	470	18.50	476	18.74	42,0	92,6				
400	16"	18	0.71	22	0.87						515	20.28	525	20.67	540	21.26	63,0	138,9				
450	18"	18	0.71	22	0.87	M24	M27	1½" UNC			565	22.24	585	23.03	578	22.76	72,0	158,7				
500	20"	18	0.71	22	0.87	M24	M30	1½" UNC			620	24.41	650	25.59	635	25.00	100,0	220,5				
600	24"	22	0.87	18	0.71	M27	M33	1½" UNC			725	28.54	770	30.31	749	29.49	190,0	418,9				

Dimensions series 68 | Lug type

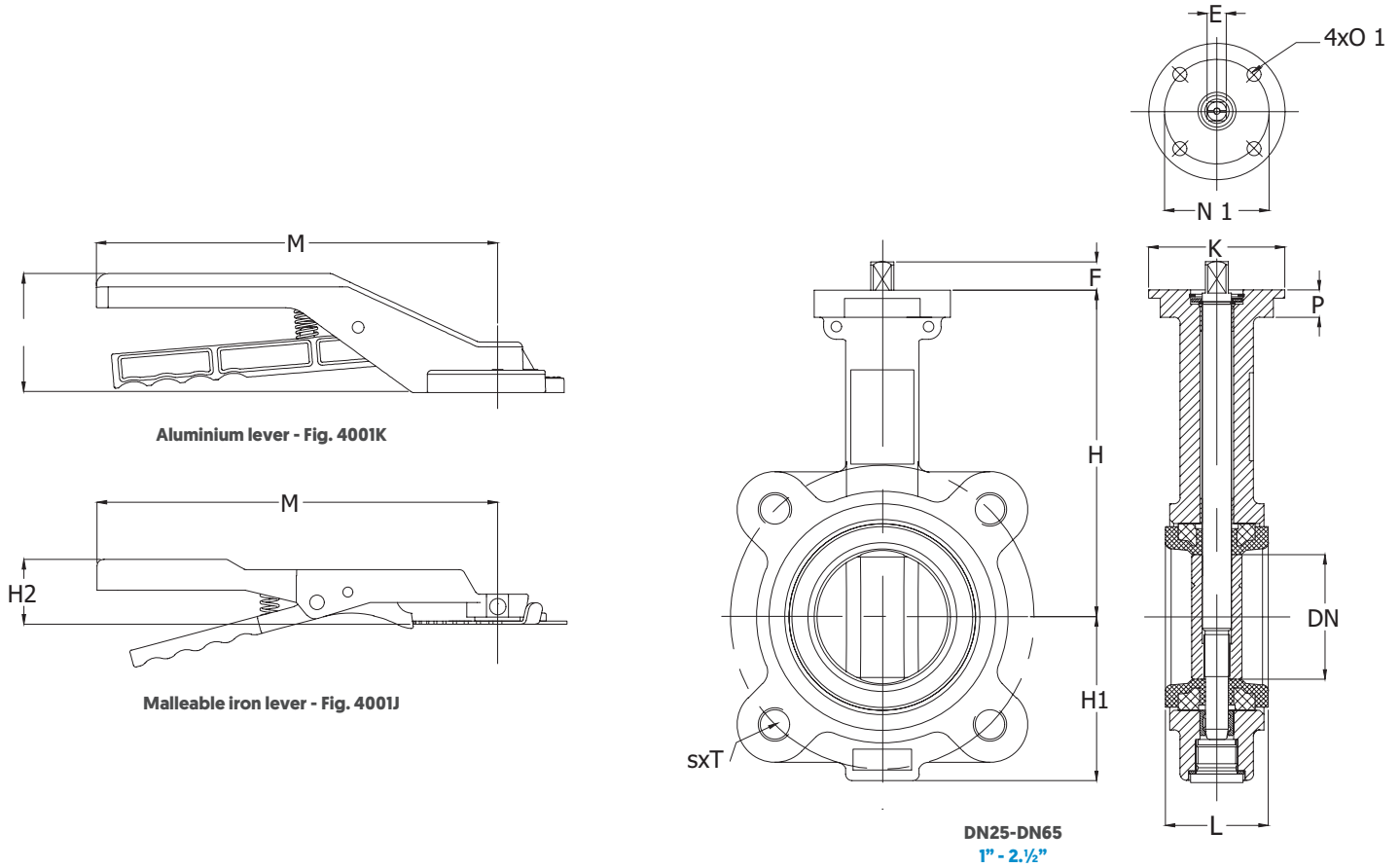

DN	NPS	H	H	H1	H1	H2	H2	H2	H2	M	M	M	M	L	L	P	P	K	K	□E	□E	F	F	ØN1	ØN1	ØN2	ØN2
mm	inch	mm	inch	mm	inch	mm	inch	mm	inch	mm	inch	mm	inch	mm	inch	mm	inch	mm	inch	mm	inch	mm	inch	mm	inch	mm	inch
25	1"	115	4.53	57	2.24	30	1.18	68	2.68	195	7.68	200	7.87	32	1.26	12	0.47	65	2.56	11	0.43	13,5	0.53	50	1.97		
32	1¼"	115	4.53	57	2.24	30	1.18	68	2.68	195	7.68	200	7.87	32	1.26	12	0.47	65	2.56	11	0.43	13,5	0.53	50	1.97		
40	1½"	115	4.53	68	2.68	30	1.18	68	2.68	195	7.68	200	7.87	33	1.30	12	0.47	65	2.56	11	0.43	13,5	0.53	50	1.97		
50	2"	143	5.63	72	2.83	30	1.18	68	2.68	265	10.43	200	7.87	43	1.69	12	0.47	65	2.56	11	0.43	13,5	0.53	50	1.97		
65	2½"	156	6.14	78	3.07	30	1.18	68	2.68	265	10.43	200	7.87	46	1.81	13	0.51	65	2.56	11	0.43	13,5	0.53	50	1.97		
80	3"	162	6.38	95	3.74	30	1.18	68	2.68	265	10.43	200	7.87	46	1.81	13	0.51	65	2.56	11	0.43	13,5	0.53	50	1.97		
100	4"	181	7.13	108	4.25	31	1.22	80	3.15	265	10.43	270	10.63	52	2.05	14	0.55	90	3.54	14	0.55	17,5	0.69	50	1.97	70	2.76
125	5"	197	7.76	123	4.84	31	1.22	80	3.15	265	10.43	270	10.63	56	2.20	14	0.55	90	3.54	14	0.55	17,5	0.69	70	2.76		
150	6"	210	8.27	138	5.43	32	1.26	80	3.15	328	12.91	270	10.63	56	2.20	14	0.55	90	3.54	17	0.67	18,5	0.73	70	2.76		
200	8"	240	9.45	168	6.61	37	1.46			386	15.20			60	2.36	16	0.63	125	4.92	17	0.67	24,5	0.96	70	2.76	102	4.02
250	10"	286	11.26	207	8.15									68	2.68	16	0.63	125	4.92	22	0.87	24,5	0.96	102	4.02	140	5.51
300	12"	309	12.17	243	9.57									78	3.07	16	0.63	150	5.91	22	0.87	30,0	1.18	102	4.02	140	5.51
350	14"	329	12.95	272	10.71									78	3.07	20	0.79	210	8.27	27	1.06	30,0	1.18	140	5.51	165	6.50
400	16"	361	14.21	342	13.46									102	4.02	20	0.79	210	8.27	27	1.06	30,0	1.18	140	5.51	165	6.50
450	18"	393	15.47	372	14.65									114	4.49	20	0.79	210	8.27	36	1.42	39,0	1.54	140	5.51	165	6.50
500	20"	427	16.81	402	15.83									127	5.00	22	0.87	210	8.27	46	1.81	49,0	1.93	140	5.51	165	6.50
600	24"	492	19.37	467	18.39									154	6.06	25	0.98	300	11.81	46	1.81	49,0	1.93	165	6.50	254	10.00

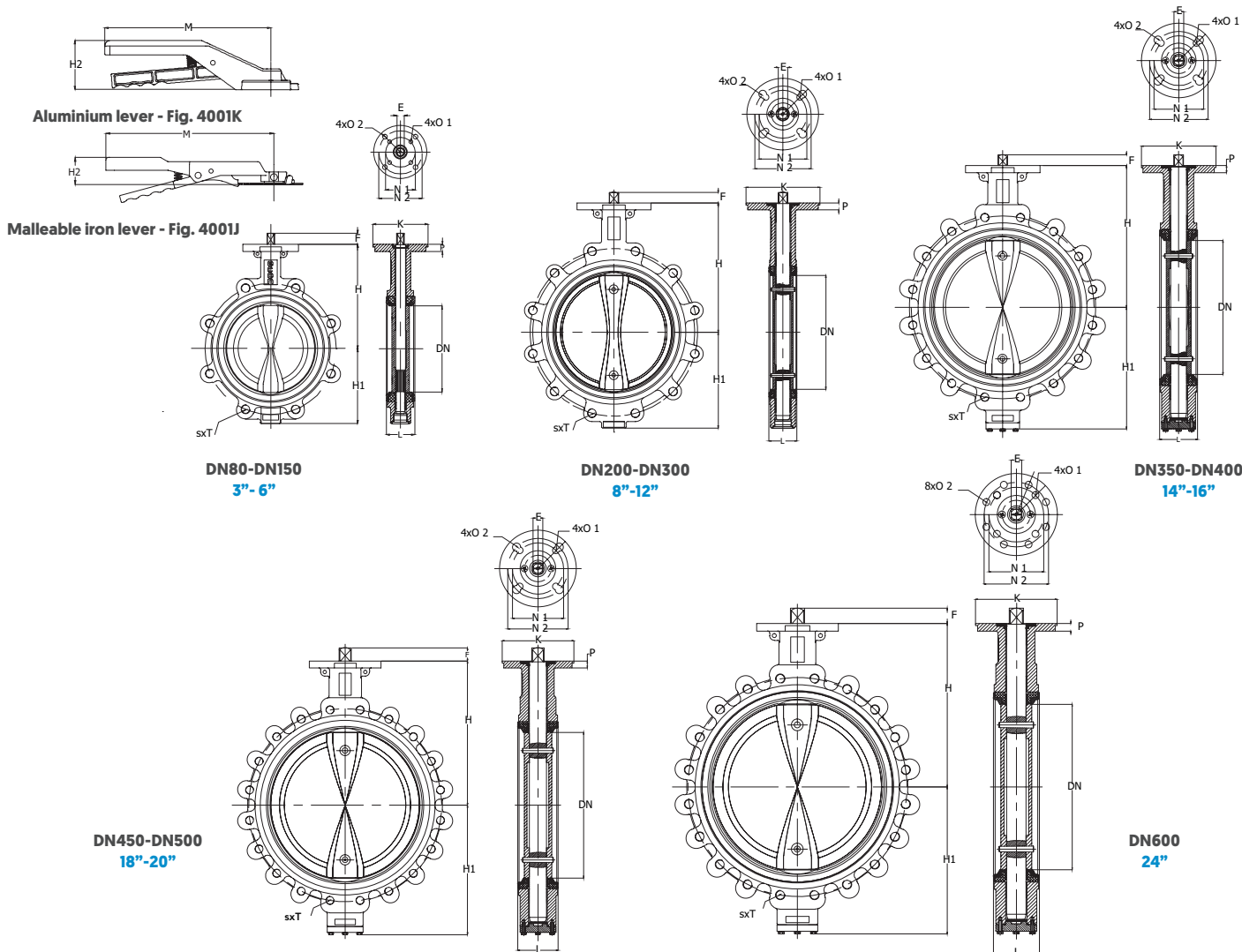

DN	NPS	ØO1	ØO1	ØO2	ØO2	s x T PN10	s x T PN16	s x T CL 150	PCD	PCD	PCD	PCD	PCD	PCD	without lever	without lever	with lever 4001J	with lever 4001J	with lever 4001K	with lever 4001K
									PN10	PN10	PN16	PN16	CL 150	CL 150						
25	1"	7	0.28			4xM12	4xM12	4x3/8" UNC	85	3.35	85	3.35	79	3.11	1,9	4.2	2,4	5.3	2,4	5.3
32	1.1/4"	7	0.28			4xM16	4xM16	4x3/8" UNC	100	3.94	100	3.94	89	3.50	2,1	4.6	2,6	5.7	2,6	5.7
40	1.1/2"	7	0.28			4xM16	4xM16	4x3/8" UNC	110	4.33	110	4.33	100	3.94	2,3	5.1	2,8	6.2	2,8	6.2
50	2	7	0.28			4xM16	4xM16	4x3/8" UNC	125	4.92	125	4.92	121	4.76	3,6	7.9	4,4	9.7	4,4	9.7
65	2.1/2"	7	0.28			4xM16	4xM16	4x3/8" UNC	145	5.71	145	5.71	140	5.51	4,2	9.3	5,0	11.0	5,0	11.0
80	3"	7	0.28			8xM16	8xM16	4x3/8" UNC	160	6.30	160	6.30	152	5.98	4,7	10.4	5,5	12.1	5,5	12.1
100	4"	7	0.28	10	0.39	8xM16	8xM16	8x3/8" UNC	180	7.09	180	7.09	190	7.48	7,5	16.5	8,3	18.3	8,3	18.3
125	5"	10	0.39			8xM16	8xM16	8x3/8" UNC	210	8.27	210	8.27	216	8.50	10,2	22.5	11,0	24.3	11,0	24.3
150	6"	10	0.39			8xM20	8xM20	8x3/4" UNC	240	9.45	240	9.45	241	9.49	11,0	24.3	12,0	26.5	12,0	26.5
200	8"	10	0.39	12	0.47	8xM20	12xM20	8x3/4" UNC	295	11.61	295	11.61	298	11.73	17,0	37.5	18,7	41.2		
250	10"	12	0.47	18	0.71	12xM20	12xM24	12x1/2" UNC	350	13.78	355	13.98	362	14.25	31,0	68.3				
300	12"	12	0.47	18	0.71	12xM20	12xM24	12x1/2" UNC	400	15.75	410	16.14	432	17.01	44,0	97.0				
350	14"	18	0.71	22	0.87	16xM20	16xM24	12x1" UNC	460	18.11	470	18.50	476	18.74	70,0	154.3				
400	16"	18	0.71	22	0.87	16xM24	16xM27	16x1" UNC	515	20.28	525	20.67	540	21.26	92,0	202.8				
450	18"	18	0.71	22	0.87	20xM24	20xM27	16x1 1/2" UNC	565	22.24	585	23.03	578	22.76	120,0	264.6				
500	20"	18	0.71	22	0.87	20xM24	20xM30	20x1 1/2" UNC	620	24.41	650	25.59	635	25.00	165,0	363.8				
600	24"	4x22	4x0.87	8x18	8x0.71	20xM27	20xM33	20x1 1/2" UNC	725	28.54	770	30.31	749	29.49	210,0	463.0				

Econ® Resilient Seated Butterfly Valve Portfolio

Series 67 and 68 | Replaceable rubber seat on a back-up ring

Design | Concentric design, replaceable seat

Main applications | Building services, Greenhouses

Valve types | Wafer type and lug type

Size range | DN25 up to DN600 (1" up to 24")

Flange connections | EN 1092-2 PN6, PN10 and PN16
ASME B16.5 Class 150

Operation | Lever, worm gearbox, pneumatic,
electric or hydraulic actuator

Available seats and discs



Series 67 with TFM1600 lined EPDM seat

Series 68

Seats	Discs
EPDM	Stainless steel
NBR / (Buna-N)	Aluminium-bronze
TFM 1600-lined EPDM	

Fig. 67311 and 68311 (with hand lever) | Fig. 67321 and 68321 (with gear box)

Replaceable rubber seat on a phenolic back-up ring

Design | Concentric design, replaceable seat

Main applications | Valves for gas distribution systems with a maximum operating pressure less than or equal to 16 bar [EN 13774]. Fuel gas applications of the first, second and third family, according to EN 437.

- 1st: Gases made of coal or oil products
- 2nd: Natural gas
- 3rd: LPG (Liquid Petroleum Gas)

Valve types | Wafer type and lug type

Size range | DN50 up to DN600 (2" up to 24")

Flange connections | EN 1092-2 PN6, PN10 and PN16
ASME B16.5 Class 150

Operation | Lever, worm gearbox, pneumatic,
electric or hydraulic actuator

Available seats and discs



Fig. 67311

Fig. 68321

Seats	Discs
DVGW-approved NBR / Buna-N	Stainless steel